



ORIGINAL.



ELECTROTYPE COPY,

by
Daniel Davis, Jr.

D A V I S ' S

Dir-26.

MANUAL OF MAGNETISM.

INCLUDING ALSO

ELECTRO-MAGNETISM, MAGNETO-ELECTRICITY,
AND THERMO-ELECTRICITY.

WITH A DESCRIPTION OF THE ELECTROTYPE PROCESS.

FOR THE USE OF STUDENTS AND LITERARY INSTITUTIONS.

WITH 100 ORIGINAL ILLUSTRATIONS.



B O S T O N :

PUBLISHED BY DANIEL DAVIS, JR.

MAGNETICAL INSTRUMENT MAKER,

No. 11 Cornhill.

1842.

Entered according to Act of Congress in the year 1842, by
DANIEL DAVIS, JR.
In the Clerk's Office of the District Court of Massachusetts.

WILLIAM S. DAMRELL,
PRINTER,
NO. 11 CORNHILL.

P R E F A C E .

MAGNETISM and Electricity have become related sciences within so short a period, and their growth has been so rapid, that many important facts which have been observed have not yet been collected in any scientific treatise, and the amount of unwritten knowledge has been constantly increasing. For this reason it has been necessary, in preparing the following work, which is intended as a companion to the apparatus manufactured by me, to give a fuller view of these sciences, and more minute descriptions of the instruments and experiments designed to illustrate them, in their relation to each other, than would otherwise have been required. This Manual, therefore, will answer the purpose of an elementary treatise on those branches of science to which it relates, and may be used as a text-book.

The aid of several gentlemen scientifically acquainted with the subject has been obtained in describing the various instruments, the experiments which may be performed with them, and the principles on which they depend. The object, which has been kept in view, is in all cases simply to state the facts which have been observed, and to generalize them only so far as the progress of discovery has fully authorized. The theories concerning magnetism and electricity in their relation to each other, which have been discussed in the scientific journals of Europe and America, must yet be regarded as hypothetical, and have been as far as possible avoided.

It will be found that many of the observations recorded here, and many of the instruments described, are new. Wood cuts have been introduced, wherever, from the nature of the instrument or experiment under consideration, it has been deemed advisable in order to ensure a clear comprehension of the subject.

Daniel Davis, Jr.

BOSTON, AUGUST, 1842.

C O N T E N T S.



INTRODUCTORY CHAPTER.

	Page
DEFINITIONS AND EXPLANATIONS,.....	1

PRODUCTION OF ELECTRICITY.

1. MECHANICAL OR FRICTIONAL ELECTRICITY,.....	6
2. GALVANIC OR VOLTAIC ELECTRICITY,.....	7
3. THERMO-ELECTRICITY,.....	21
4. ANIMAL ELECTRICITY,.....	34

MAGNETISM.

CHAPTER I.

DIRECTIVE TENDENCY OF THE MAGNET.

1. IN REFERENCE TO ANOTHER MAGNET,	35
2. IN REFERENCE TO A CURRENT OF ELECTRICITY,	43
3. IN REFERENCE TO THE EARTH,.....	52

CHAPTER II.

INDUCTION OF MAGNETISM.

	Page.
1. BY THE INFLUENCE OF A MAGNET,.....	61
2. BY THE INFLUENCE OF A CURRENT OF ELECTRICITY,.....	68
3. BY THE INFLUENCE OF THE EARTH,.....	122

CHAPTER III.

INDUCTION OF ELECTRICITY.

1. BY THE INFLUENCE OF A CURRENT OF ELECTRICITY,.....	125
2. BY THE INFLUENCE OF A MAGNET,.....	153
3. BY THE INFLUENCE OF THE EARTH,.....	197

THE ELECTROTYPE PROCESS.

1. ORIGIN OF THE ELECTROTYPE,.....	199
2. PROCESSES FOR ELECTROTYPES IN COPPER,	200
3. PROCESSES FOR GILDING, SILVERING, AND PLATINATING,..	205

INTRODUCTORY CHAPTER.

DEFINITIONS AND EXPLANATIONS.

1. **MAGNETISM.** The term *magnetism* expresses the peculiar properties of attraction, repulsion, &c., possessed, under certain circumstances, by iron and some of its compounds, and in a feebler degree by the metals nickel and cobalt. Hammered brass is said to be sometimes magnetic. The science which treats of these properties is also called magnetism.

ELECTRO-MAGNETISM. That branch of science which relates to the development of magnetism by means of a current of electricity, is called electro-magnetism. It will be treated of in chapter I, section 2, and in chapter II, section 2.

MAGNETO-ELECTRICITY treats of the development of electricity by the influence of magnetism, and will form the subject of chapter III, section 2.

2. **THE MAGNET.** Any body in which the magnetic phenomena manifest themselves, is called a *magnet*. It may be of any form, but it must be composed in whole or in part of iron, nickel, or cobalt.

NATURAL MAGNETS. Certain ores of iron are found to be possessed of the magnetic properties in their natural state. These are called *natural magnets*, or *loadstones*.

ARTIFICIAL MAGNETS. Bodies of whatever form or composition, in which magnetism is artificially *induced*, are called *artificial magnets*.

3. INDUCTION OF MAGNETISM. Whenever magnetic properties are developed in bodies not previously possessed of them, the process is termed the *induction of magnetism*. When this is effected by the influence of a magnet, it is called *magnetic induction*: when by a current of electricity, *electro-magnetic induction*.

INDUCTION OF ELECTRICITY, is whenever electricity is developed by the influence of other electricity in its neighborhood, or by the influence of magnetism. In order to distinguish the inductive action of an electric current from the *static induction* of electricity at rest, the former is called *electro-dynamic induction*. The development of electricity by the influence of a magnet is termed *magneto-electric induction*.

4. POLES. The magnetic phenomena manifest themselves principally at the two opposite extremities of the magnet: as may be shown with regard to the attractive force by the following experiment:

EXP. 1.—Immerse a magnet in iron filings and then withdraw it. A considerable quantity of the filings will be found to adhere to it; being accumulated most abundantly about its ends, while few or none will be attached to its middle: thus proving the attractive force to be strongest at the extremities, and to diminish rapidly as the distance from them increases, until it becomes entirely insensible at the middle point. These extremities are called the *poles* of the magnet.

5. The earth itself is found to possess the properties of a magnet, having magnetic poles corresponding nearly in their direction with the poles of its diurnal rotation.

Now if a straight magnet be suspended so as to allow of a free horizontal motion, it will be found to place itself in a direction nearly north and south: as will be explained hereafter. The end which turns towards the north is called the *north pole* of the magnet, the other end its *south pole*. Hence every magnet, whatever its form, is said to have a north and a south pole. In the figures to be hereafter described, the north pole is indicated by the point of an arrow, and the south pole by the feather. The *poles* of a galvanic battery will be described when treating of that instrument.

6. PERMANENT MAGNETS. It is found that pure soft iron easily acquires magnetism when exposed to any magnetic influence, but immediately loses this magnetism when that influence is withdrawn. But steel, which is a compound of iron with a small quantity of carbon, and especially hardened cast-steel, though it acquires the magnetic properties less readily, retains them more or less permanently after they are acquired. Hence a magnet formed of hardened steel is called a *permanent magnet*.

7. BAR MAGNET. An artificial permanent magnet in the form of a straight bar, is called a *bar magnet*.

Fig. 1.

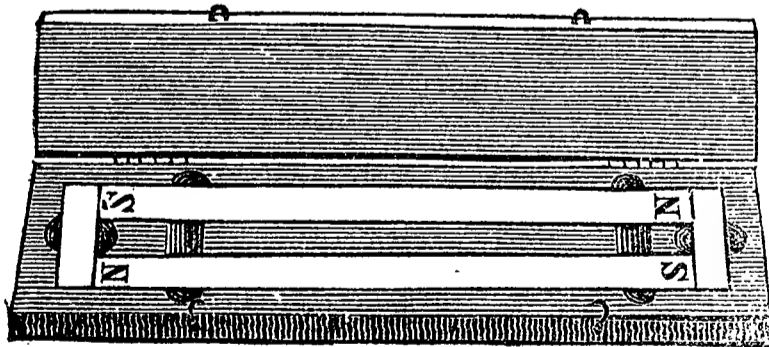
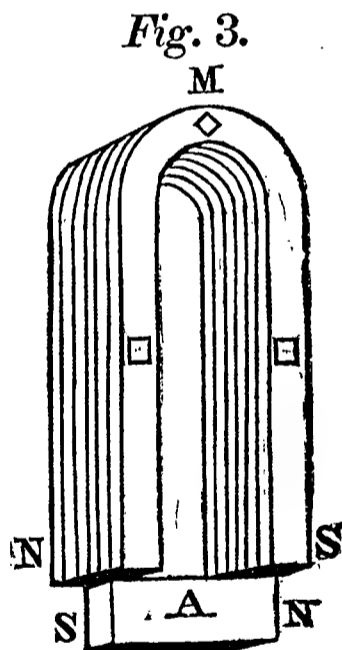
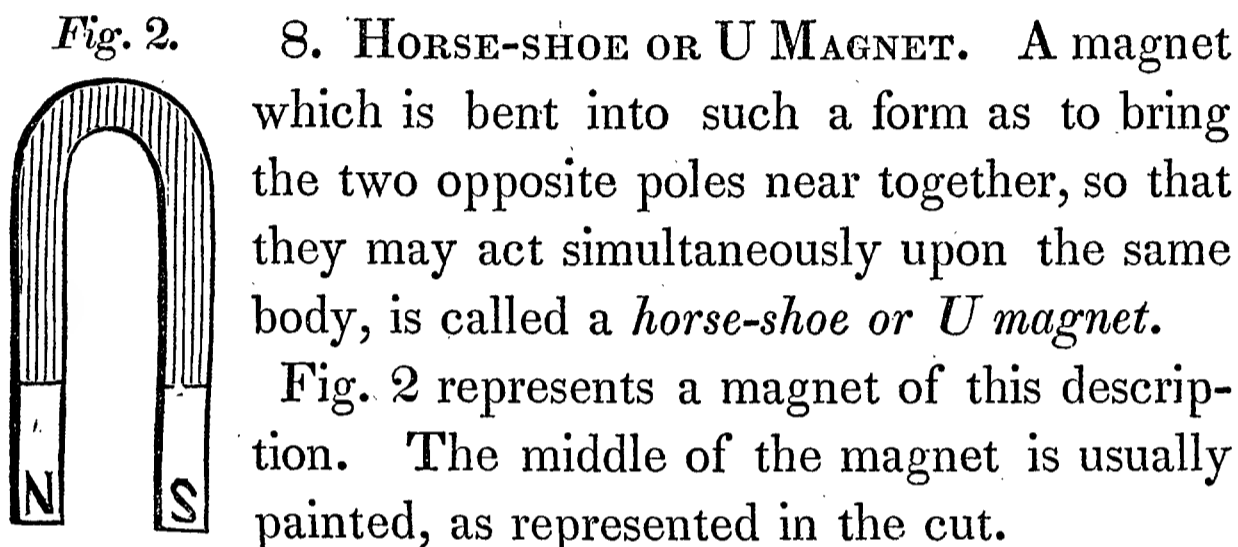

Fig. 1 represents a small case containing two bar magnets, with two short pieces of soft iron connecting their poles: these act as *armatures* (see § 9), and serve to preserve the power of the magnets. The magnets, when

not in use, should be kept packed in the case, with their opposite poles connected by the armatures, in the manner shown in the cut.

COMPOUND BAR MAGNET. A magnet composed of several straight bars joined together, side by side, with their similar poles in contact, for the purpose of increasing the magnetic power, is called a *compound bar magnet*.



COMPOUND HORSE-SHOE MAGNET. A magnet composed of several horse-shoe magnets joined together, side by side, as in *fig. 3*, for the purpose of increasing the power, is called a *compound horse-shoe magnet* or *magnetic battery*. These magnets are charged separately, and are put together with all the similar poles in the same direction.

9. **ARMATURE.** A piece of soft iron, adapted to, and intended to connect the poles of a magnet, is called an *armature*, or *keeper*. Horse-shoe magnets are usually provided with an armature, consisting of a straight bar of iron, for the purpose of preserving their magnetic

power: this should be kept constantly applied to the poles of the magnet when it is not in use; as shown in fig. 3, where A is the keeper. Armatures are employed in various experiments, and their forms vary with the purposes intended.

Fig. 4.

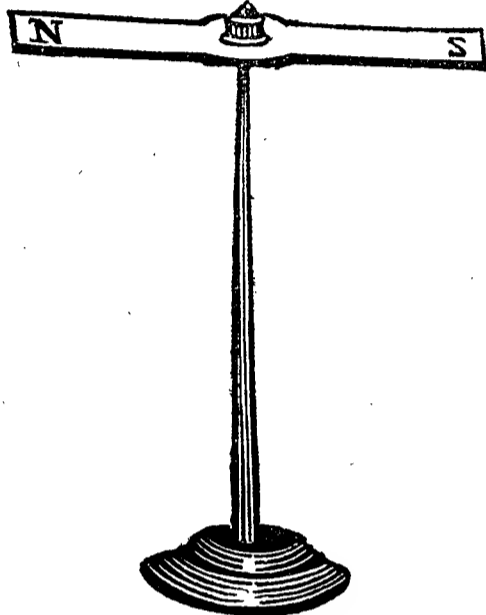

10. MAGNETIC NEEDLE. A light and slender magnet, mounted upon a centre of motion, as in fig. 4, so as to allow it to traverse freely in certain directions, is called a *magnetic needle*.

11. The most obvious effects exhibited by magnets are their power to attract iron, and their tendency, when freely suspended, to assume a determinate position in reference to the earth. For a long time these were the only properties which were noticed, or at least which received particular attention. The attractive power of the loadstone over small pieces of iron seems to have been known from the remotest antiquity; but its polarity with regard to the earth does not appear to have been observed until the eleventh or twelfth century of the Christian era.

PRODUCTION OF ELECTRICITY.

12. As a current of electricity is requisite in many of the experiments to be mentioned hereafter, it becomes necessary to describe the various means by which it may be produced.

I. MECHANICAL OR FRICTIONAL ELECTRICITY.

The electricity developed by the electrical machine is called mechanical or frictional, from the mechanical force or friction by which it is obtained. It possesses properties differing much in degree from those exhibited by the galvanic arrangements described below, and is altogether less capable of producing magnetical effects. Mechanical electricity is also developed, though not in so striking a manner, by the pressure of some minerals, and of certain elastic substances, such as India rubber.

13. The great development of electricity recently observed during the escape of steam from high pressure boilers, may also be mentioned here. This is collected for purposes of experiment, by plunging into the steam, escaping from a safety valve, a brass rod (fig. 5) furnished with a brush of points P, at one end, to collect

Fig. 5.

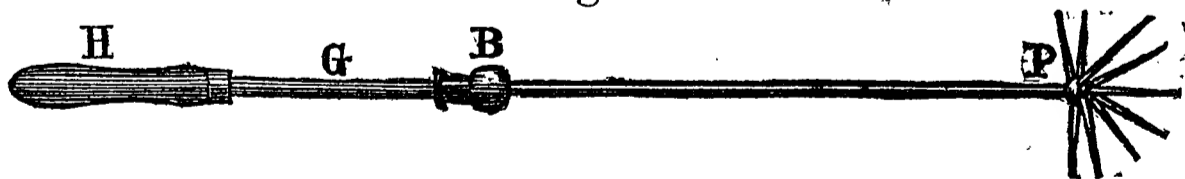

the electricity, and held by means of a glass insulating handle attached to the other end. A length of six or eight feet is found advantageous in this instrument, to

convey and insulate the electricity, which may be conveniently drawn from the lower part of the rod. In the cut, the brass rod is represented as terminating in a brass ball B, and insulated from the wooden handle H by a stout glass rod G.

The electricity obtained in this way from steam is of high intensity, affording sparks of an inch or more in length, and charging the Leyden jar so as to give strong shocks. It is almost always *positive*, and is not obtained unless the steam is of high pressure so as to issue from the valve as a transparent vapor.

II. GALVANIC OR VOLTAIC ELECTRICITY.

14. These names are given to that form of electricity which is produced by chemical action. It is found, that when two metals are placed in connection with some liquid capable of acting more powerfully upon one than upon the other, electricity of a peculiar character is developed. The metals usually employed are zinc and copper, and the chemical agent some liquid containing an acid having a powerful affinity for the zinc. The phraseology used in describing the effect is founded upon the idea, that electricity is given out to the copper from

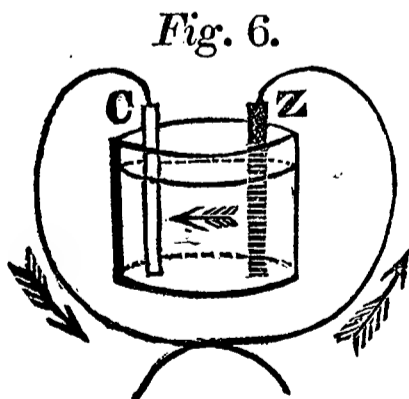

Fig. 6.

the zinc, through the liquid between them; as is shown in the adjoining cut, fig. 6, which represents a vessel of some non-conducting substance, as glass, partly filled with the fluid, and containing a zinc plate marked Z, and one of copper, C. Now the supposed motion of the electric current within the vessel is from Z to C;

then, if a wire passing from C is brought in contact with another from Z, as represented in the figure, the electricity will pass around through the wires from the copper to the zinc again. Thus the current is considered as passing from zinc to copper *within* the series, and from copper to zinc *without* it. C is therefore called the *positive* or delivering pole of the arrangement, and Z the *negative* or receiving pole. This, however, must not be considered as an established theory, but only as the idea on which the phraseology is founded. For whether there is one fluid flowing in the direction above described, or two flowing in opposite directions, or no motion of a fluid at all, is still a matter of discussion among philosophers.

15. In order to avoid the inconvenience of having phraseology in use which is based upon a doubtful theory, some philosophers call the two opposite extremities of the galvanic arrangement *electrodes*, that is, *ways* or *paths* of electricity. To distinguish the two, they call the copper end the *anode*, and the zinc end the *cathode*. The terms *positive pole* and *negative pole* are, however, still most frequently employed to designate these extremities; and the wire without, when in connection with these poles, is spoken of as the channel of a positive current passing from the former to the latter. This language, however, as has been already remarked, must be considered as conventional, and not as an expression of actual facts.

16. Instead of using two metals to form the galvanic circuit, one metal in different conditions may be used on the same principle; the necessary condition of this

current being only that one part of a conductor of electricity shall be more corroded by some chemical agent than another part. Thus, if a galvanic pair be made of the same metal, one part of which shall be softer than another, as of cast and rolled zinc, so as to be differently corroded, or if a greater amount of surface be exposed to corrosion on one side than on the other, or a more corrosive chemical agent be used on one side, a current will be determined from the part most corroded through the liquid to the part least corroded, whenever the circuit of the poles is completed.

17. There are two modes by which the peculiar powers of a galvanic arrangement, like the one previously described, may be increased. First, by increasing the size of the plates used; and secondly, by increasing their number. 1. *The extension of the size of the plates.* If the size of the plates, that is the extent of the surfaces acted upon by the chemical agent, is increased, some of the resulting effects become more powerful in the same ratio, while others do not. The power to develop heat and magnetism is increased, while the power to decompose chemical compounds and to affect the animal system is very slightly or not at all augmented. Batteries constructed in this way, of large plates, are sometimes called *calorimotors*, from their great power of producing heat; and they usually consist of from one to eight pairs of plates. They are made of various forms. Sometimes the sheets of copper and zinc are coiled in concentric spirals, sometimes placed side by side; and they may be divided into a great number of small plates, provided that all the zinc plates are connected together,

and all the copper plates together, and then, finally, that the experiments are performed in a channel of electrical communication opened between the one congeries and the other; for it is immaterial whether one large surface be used, or many small surfaces, electrically connected together. The modification of electricity which such arrangements develop, is said to be great in *quantity*.

2. *The extension of the number of the plates consecutively.* That is, by connecting the copper plate of each pair with the zinc plate of the next pair. By this arrangement, the electricity is obliged to traverse a longer or shorter series of pairs; each pair being separated from the adjoining ones by a stratum of imperfectly conducting liquid. The result is, that the electricity acquires what is called *intensity*. It has greater power to pass through imperfect conductors, or through intervals in the circuit, to give shocks to the animal system and to decompose chemical compounds; and when the number of consecutive pairs of plates is increased to some thousands or even hundreds, the electricity developed approaches very near in its character to that produced by the electrical machine; it manifests similar attractions and repulsions, and in fact the Leyden jar may be charged with it. These different modifications of electricity are therefore spoken of as characterized by different degrees of intensity. That which is obtained from one pair of plates has a very low intensity. As the number of consecutive pairs is multiplied, the intensity increases, until at length it approximates to that of frictional electricity, which is able to strike across a considerable interval of air, and to fracture solid non-conductors interposed in its circuit.

18. In consequence of the low intensity of the electricity required for electro-magnetic experiments, it is very easy of insulation. This is a great advantage in regard to the practical construction of magnetic apparatus. Where electricity exists in a state of high intensity, it has a strong tendency to pass off and dissipate itself through imperfect conductors; but where it exists only in great *quantity*, it requires nearly perfect conductors to allow it a passage. The electricity developed by a single pair of plates, however much its power may be increased by increasing the size of the plates, will scarcely pass across the smallest interval of air, and a wire conveying the current may be perfectly insulated by a covering of varnish. In working the electrical machine, on the other hand, the electrified parts of the apparatus must be kept at a distance from each other, raised on tall glass supports, or suspended by long silken lines; and then, unless the atmosphere is very dry, the electricity will be very rapidly dissipated. But in the case of currents of low intensity, however great what is called the *quantity* may be, two wires may lie side by side, with a coating of varnish or wax between them, and convey different and opposite currents, without any perceptible electrical intercommunication.

19. Now for the purposes of magnetic experiments, electricity of a low intensity is required; for the power of the magnetical effects of a current of electricity depends upon an increase of its *quantity*, mainly. Increasing the number of consecutive pairs, would only add to the *intensity* of the current, making it more unmanageable in respect to insulation, without adding much to

its magnetic effects. Galvanic batteries having many pairs of plates, are therefore unsuitable for these experiments. The maximum magnetic effect is produced by a single galvanic combination, or at most by three or four; the condition for the production of the effect being the extent of the surface acted upon. The form found most convenient is the following.

20. *Cylindrical Battery.*

Fig. 7.

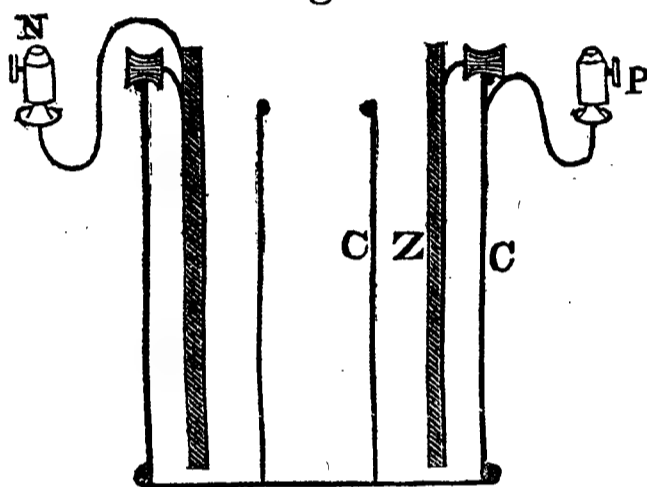

This battery, a vertical section of which is represented in fig. 7, consists of a double cylinder of copper, C C, with a bottom of the same metal; which answers the purpose both of a galvanic plate and of a vessel to

contain the chemical solution. The space between the two copper cylinders is the receptacle for the solution. There is a movable cylinder of zinc, marked Z in the section, which is to be let down into this solution whenever the battery is to be put in action. It is, of course, intermediate in size, as well as in position, between the two copper cylinders; and is made to rest upon the exterior one by means of three insulating branches of wood or ivory, projecting from it outwardly. Thus it hangs suspended in the solution, and presents its two opposite surfaces to the action of the liquid, and to the inner and outer cylinders of copper respectively. There is a binding screw cup N connected with the zinc cylinder, and also one marked P, with the copper cylinder; and, according to the principles heretofore explained,

when a communication is made between these cups, the electricity developed by the action within the battery will pass from one to the other.

21. *Chemical agent.* The liquid employed for putting this battery in action is a solution of the sulphate of copper (the common blue vitriol) in water. To prepare it, a saturated solution of the salt is first made, and to this solution is then added as much more water. It may be convenient to know, that a pint of water, at the ordinary temperatures of the atmosphere, is capable of dissolving one fourth of a pound of blue vitriol; so that the half saturated solution employed will contain about two ounces of the salt to the pint. The zinc is oxydized by the oxygen of the water; the oxide combines with the acid of the salt, forming sulphate of zinc, which remains in solution; while the oxide of copper, which was previously combined with the acid, being set free, partly adheres to the surface of the zinc cylinder, or falls to the bottom of the solution as a black powder, and partly is reduced to metallic copper, which is precipitated on the surface of the copper cylinder, or falls to the bottom in fine grains. This reduction of the oxide to the metallic state takes place in the following manner. The water of the solution furnishes oxygen to the zinc, and thus enables it to combine with the acid, while the hydrogen which is liberated, again forms water with the oxygen of any oxide of copper with which it may come in contact, leaving the metal free. Hence but little gas is given off during the action of a battery charged by sulphate of copper, as the hydrogen, which usually escapes, is in this case mostly absorbed. The coating of oxide

of copper should always be removed from the zinc after using the battery. For this purpose a card brush is provided. With this the surface of the zinc should be thoroughly cleansed, with the aid of plenty of water, whenever it has been in use. If this has been neglected, so that the zinc has become covered, in whole or in part, with a hard coating, it will be necessary to scrape or file it to obtain a clean metallic surface. The deposit of copper, also, which will gradually accumulate below, must be removed from time to time.

22. The zinc cylinder should of course be always taken out of the solution when the battery is not in use, but the solution itself may remain in the battery, as it has no chemical action upon the copper, but tends to keep its surface in good condition. When the solution has lost its power, as it will do, of course, after a time, it is not best to attempt to renew its efficiency by adding a fresh quantity of the salt. It should be thrown away, and a new solution be prepared, according to the foregoing directions.

23. These cylindrical batteries are made, for the purposes of magnetical experiments, of three sizes, called the large, small, and medium sizes.

24. When a current of electricity is passed through a metallic wire in greater quantity than it can readily transmit, the wire becomes more or less heated; if its length and thickness be proportioned to the power of the battery, it may readily be melted. A single pair of plates would be the most efficient arrangement for producing this effect, were it not that an increase of intensity enables a greater quantity of electricity to traverse the wire. Hence, for igniting a great length

of wire, a battery of a considerable number of pairs is necessary ; but a much thicker wire may be ignited by a few pairs of large size. When a very extensive series of small plates is used, the current acquires so high an intensity that its power of producing ignition is diminished, as it becomes capable of traversing a pretty fine wire without obstruction.

25. Metals differ very much in their power of conducting galvanic electricity. The following are several of the most useful metals, in the order of their conducting power ; viz. silver, copper, brass, iron, platinum. For conducting wires, copper is generally used ; for delicate connections, silver. Iron and platinum are used where it is an object to employ the poorest conductors, as in the following experiment.

EXP. 2.—Either of the batteries mentioned in § 23 has sufficient power to ignite a fine wire of iron or other metal, through which the current is made to pass. This effect is most easily produced in those metals which offer the greatest resistance not only to the passage of electricity, but also to that of heat ; hence a larger wire of platinum may be ignited than of perhaps any other metal, as that is a poor conductor both of electricity and of heat. A steel wire, when intensely heated in this way, burns with beautiful scintillations. The shorter and finer the wire, within certain limits, the greater is the effect produced.

Fig. 8.

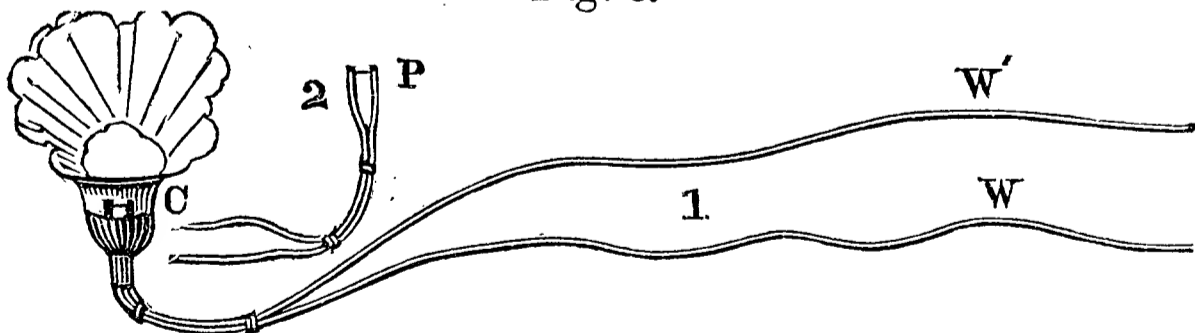

26. *The Powder Cup.* Fig. 8, No. 1, represents a little instrument designed to show the heating power of the

battery current. Two copper wires, *W* and *W'*, wound with cotton thread, except at their ends, are joined by a short piece of fine platinum wire *P*, No. 2. These wires pass through the bottom of a small glass cup, *C*, so that the platinum wire lies free in its cavity. On putting a little gunpowder into the cup *C*, and then connecting *W* and *W'* with the poles of the battery, the platinum will become heated, in consequence of the flow of the current through it, so as to inflame the powder.

27. *The Voltaic Gas Pistol*, represented in fig. 9, is constructed on the same principle as the last described in-

Fig. 9.

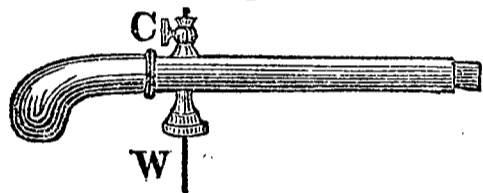

strument. The wire *W* passes up through a brass piece which screws into the barrel; the wire being

completely insulated from the brass. A sectional view of this part is annexed. One end of the fine platinum wire *P* is connected with *W*, the other with the brass piece. A stop-cock *C* is added, to insure the introduction of a proper quantity of hydrogen. This object is effected in the following manner: Connect with a self-regulating reservoir of hydrogen, a leaden or other tube, so bent as to deliver the gas under the surface of water in a jar. The pistol being uncorked and the stop-cock open, immerse the muzzle in the jar to such a depth that the water may fill one quarter of the barrel. Then close *C*, and bringing the muzzle over the end of the tube, open the stop-cock of the reservoir. When the escape of bubbles shows the pistol to be full of gas, withdraw it, and insert the cork. In this way it will contain one volume of hydrogen to three of air, which

is the best proportion. If too much hydrogen is introduced, no explosion will occur; it is not, however, necessary to be very particular; and it will answer the purpose, if the pistol is held for a few moments over a jet of the gas. The explosion is louder and more certain to occur, if it is filled with a mixture of oxygen and hydrogen, in the proportion of one volume of the former to two of the latter.

28. The pistol being corked and the stop-cock closed, connect W with one pole of the battery and bring the wire from the other pole in contact with the stop-cock, or any part of the barrel. The circuit will now be completed through the platinum wire; this will instantly be ignited, setting fire to the gas, which will expel the cork with a loud report. The stop-cock C allows the mixed gases to be fired by the application of flame when desired.

29. By connecting two or three batteries (§ 20) of the same size together consecutively, that is to say, the zinc of one with the copper of the other, the power of the current will be greatly increased. For most experiments relating to magnetism there is no advantage in extending the series beyond this. Any number, however, of single batteries may be usefully combined, where great power is desired, by dividing them into two or three sets, and uniting the plates of each set among themselves, copper with copper, and zinc with zinc; the sets may then be connected consecutively.

30. Where a battery of a number of pairs is wanted, the arrangement represented in fig. 10 is very convenient. The zinc plates are flat, and are enclosed in copper

cases, open only at top and bottom; each zinc plate

Fig. 10.

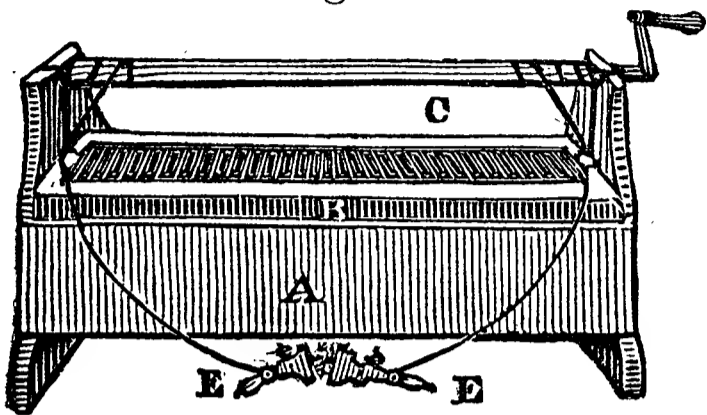

being insulated from the surrounding copper by slips of wood at the edges, and connected by a strip of copper soldered to it, with the case belonging to the

next pair. The whole series is firmly fixed in a wooden frame B; pieces of pasteboard soaked in melted wax being interposed between the adjacent copper cases. By means of the windlass C, the frame, with the plates, may be raised out of the trough A, containing the exciting liquid, or allowed to descend into it at pleasure. Diluted acid is employed for the charge, in preference to a solution of sulphate of copper: sulphuric acid, one part, with forty or fifty parts of water, is very good; if greater power is desired, a little nitric acid may be added. E E are small hand-vices, connected with the poles, for the purpose of holding wires, &c. The battery represented in the cut, consisting of twenty-five pairs of plates, is able to ignite a considerable length of wire, to decompose acidulated water with rapidity, and to give a brilliant light with charcoal points.

31. Fig. 11 represents a still more powerful battery. There are two distinct series of fifty pairs, each connected with two of the cups on the table above the battery. In this way the whole may be used as a single series of one hundred pairs, or as a battery of fifty pairs of double size, by establishing proper connections between these cups. Or only half the battery may be put in action;

Fig. 11.

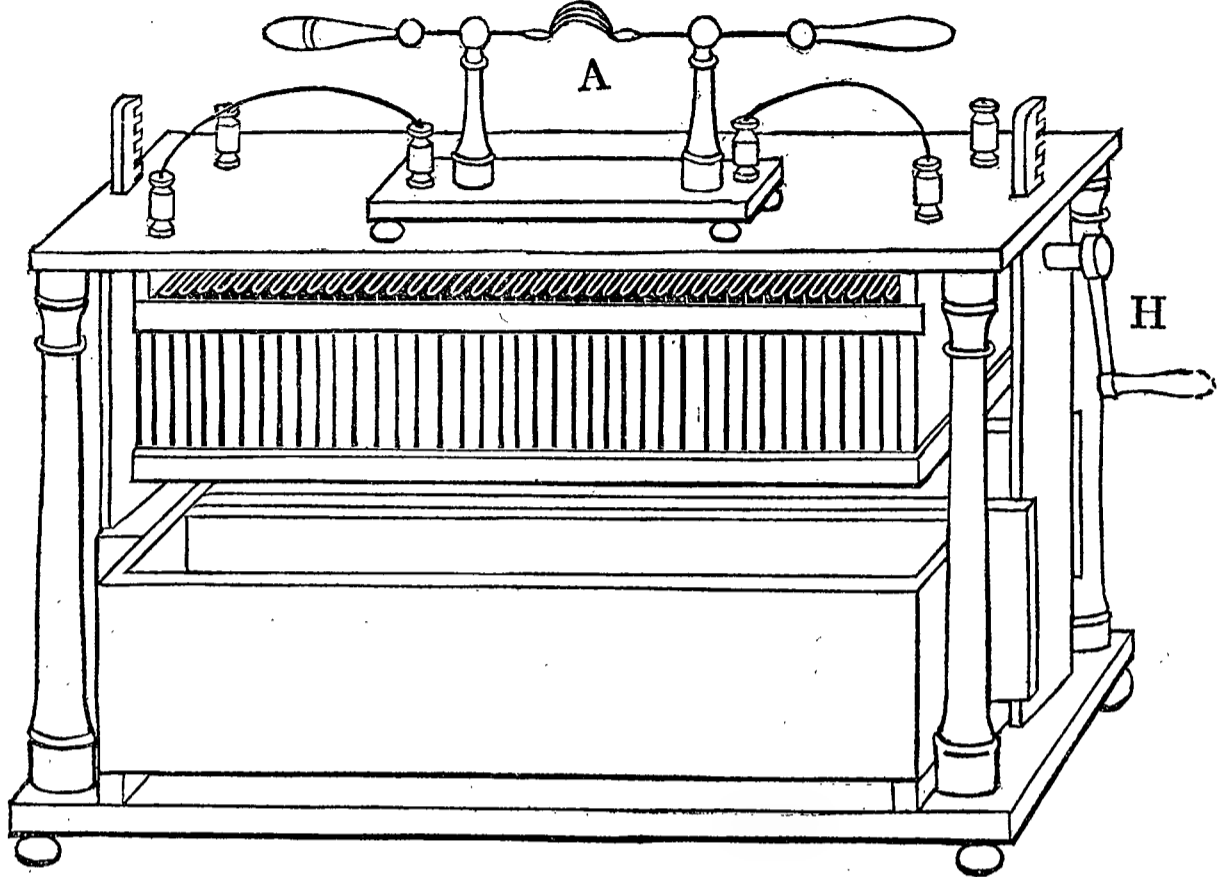

each having a separate trough to contain the acid. The plates are stationary, and the troughs are raised up to them by means of two racks moved by the crank and handle H, which lift the platform on which the troughs stand: either trough may be removed from the platform at pleasure, when it is wished to use only half of the battery.

32. In the cut, the arrangement for producing the arch of flame between charcoal points is shown. Two pointed pieces of prepared boxwood charcoal are fixed in the pincers at A, and the battery being put in action, are brought in contact. The spark passes and the points become ignited; they may then be separated to a greater or less distance, in proportion to the power of the battery, and the current will continue to flow through the interval with the production of intense light and heat.

33. In the batteries described in § 30 and 31 in which the plates are fixed permanently in a frame, the solution of sulphate of copper cannot be employed, on account of the deposit which it forms. Hence diluted acid is used ; and the batteries will not maintain a good action for more than a few minutes at a time ; in fact their highest rate of action only continues for a few seconds after immersion. The plates require to be taken out of the acid occasionally during the experiments, and exposed to the air a minute or two. The batteries worked by sulphate of copper will keep in good action for fifteen or thirty minutes at a time.

34. When the zinc and copper plates are separated by a porous partition or membrane, on each side of which a different solution is put, so that one solution comes in contact with the copper, and the other with the zinc plate, the battery is called a *sustaining* or *constant* battery, because it maintains a nearly uniform power for hours and days in succession. This arrangement is very useful for many purposes, and will be more particularly described hereafter when we come to speak of experiments which require a steady and constant current.

35. The wires used for conveying the electrical current in electro-magnetic and magneto-electric experiments are wound with cotton thread, and sometimes, in addition, covered with varnish. This is sufficient for their perfect insulation, as the electrical current employed is one of very low intensity. The extremities of the communicating wires should be kept clean and bright ; it is often advantageous to tin them, or cover them with

soft solder, when the connections are made by means of mercury cups, as they then become amalgamated when dipped into the mercury, and thus form a perfect metallic contact.

III. THERMO-ELECTRICITY.

36. The term *Thermo-Electricity* expresses the development of electricity by the agency of heat. It was discovered by Prof. Seebeck, of Berlin, in 1822, that if the junction of two dissimilar metals was heated, an electrical current would flow from one to the other. Thus, if the ends of two wires, or strips of German silver and brass are made to touch each other, or are brazed together, and the junction heated, a current will flow from the German silver to the brass, if the free extremities of the wires are connected by any conductor of electricity, and an electrical circuit will be established, as the galvanic circuit is established by connecting the

Fig. 12.

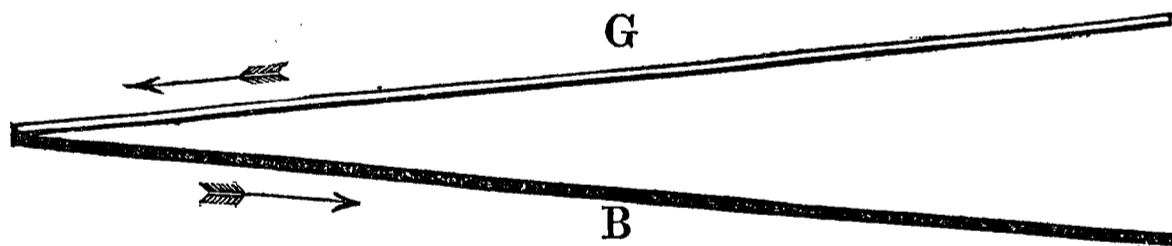

poles of the battery. In the cut, fig. 12, G represents the German silver, and B the brass; the direction of the current being indicated by the arrows.

37. In thermo-electricity, as in galvanism, instead of two metals, one metal, in different conditions, can be used to excite a current. Thus, merely twisting the middle of an iron or platinum wire, and heating it on

one side of the twisted portion, will produce a current flowing, at the heated part, from the untwisted to the twisted portion, whenever the extremes are connected.

38. A current may also be excited with two wires of the same metal, by heating the end of one and bringing it in contact with the other. It is difficult to succeed in this experiment when metals are used whose conducting power for heat is great. Thus copper or silver wires produce a very feeble current, but iron or platinum an energetic one, especially when the ends, which are brought in contact, are twisted into a spiral. The direction of the current at the junction is from the cold to the hot wire; and it ceases as soon as an equilibrium of temperature is established between the two. A considerable current is also produced by heating the junction of two platinum wires of different diameters. The current flows from the fine to the coarse wire, whether the heat is applied at the point of junction or to either wire at a little distance from it. In large arrangements, plates or strips of dissimilar metals are generally used.

39. The cause of the thermo-electric current, thus excited between two metals, is generally referred to the difference in their conducting power for heat, and to the different orders of crystallization to which their particles belong, the laws of crystallization being supposed to result from the electrical character of the particles. Where the same metal in different conditions is used, the production of electricity is referred to the unequal propagation of heat on each side of the heated point, caused in the single wire by the obstruction occasioned by the twist, and in the case of two wires, by the contact

of the cold wire, or where they are connected together, by the difference in their diameters. The causes, however, have not yet been fully investigated, and many points are involved in great obscurity.

40. Metals differ greatly in their power to excite a current, when associated together in thermo-electric pairs. Some of the peculiarities in the combinations of the more useful metals are given in § 43. It is necessary, however, to say a few words with regard to the *galvanometer*, an instrument to indicate or measure electrical currents, and which is more fully described in chapter I, section 2. A current of electricity passing through a wire or coil of wire, is found to deflect a magnetic needle in its neighborhood. By an arrangement, such as fig. 13, where G is the galvanometer, consisting of a magnetic needle in

Fig. 13.

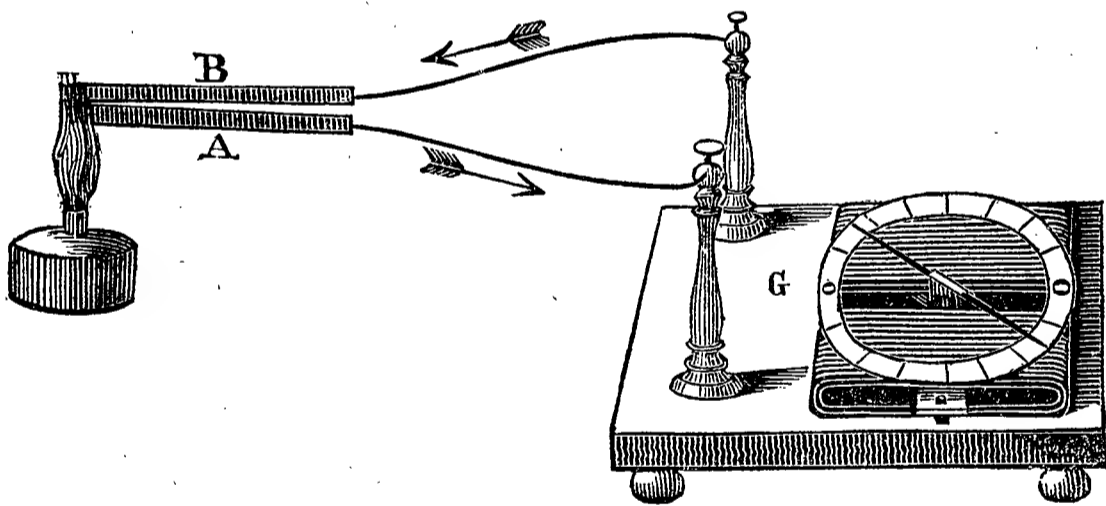

close proximity to a coil of wire, above which is fixed a graduated circle, the direction of an electrical current made to pass through the wire is indicated by the deflection of the needle from the north and south line, in one direction or the other, and its strength is measured by the number of degrees to which it is deflected. The *deflection of the needle* will be frequently

alluded to hereafter. In the figure, a thermo-electric pair, of bismuth and antimony, heated by a spirit lamp, is shown in connection with the galvanometer. The arrows indicate the course of the current from the antimony A to the bismuth B, in the exterior circuit; its direction being of course the reverse of that at the junction, where it flows from B to A.

41. The character of the juncture between the plates or wires has an important influence on the amount of the current with the same metals. Frequently, when the elements of the pair are merely made to touch each other, the current is greater than when they are brazed or soldered together. Generally, the slighter the connections are, the better. They must be sufficient to conduct all the electricity generated, but no more, for if they are unnecessarily large, they allow the electricity to return to the metal whence it proceeded, without accomplishing the circuit.

42. The metal from which the current proceeds through the heated junction is exactly analogous in situation to the zinc or positive plate in the galvanic pair, from which the current proceeds through the liquid of the battery, § 14. The metal to which the current proceeds through the junction is analogous to the copper or negative plate. The positive or delivering pole of the thermo-electric pair is the extremity of the negative or receiving metal, as the copper pole is the positive pole of the battery. The negative thermo-electric pole is the extremity of the positive metal. In the observations and table which follow, the positive element of the pair, answering to the zinc in a galvanic pair, will always be placed first.

43. *German Silver and Antimony.* The current excited by these is greater than that from bismuth and antimony at the same temperature. Their junctions being put into hot oil, of a fixed temperature, and the free ends of the plates connected with the galvanometer used in these experiments, the bismuth and antimony occasioned a constant deflection of the needle of 75° ; the German silver and antimony, a deflection of 85° ; the heat being increased with the bismuth and antimony to the melting point of bismuth, the deflection was 82° , while the German silver and antimony, heated in a spirit lamp, gave a deflection of 88° .

Bismuth and Antimony. Plates of these metals have been heretofore generally used in large thermoelectric arrangements. The current excited by heating their junctions is greater than from many other metals, when a feeble heat is used; but from the fusibility of bismuth, the heat can never be raised very high. The current flows through the junction from the bismuth to the antimony.

44. *German Silver and Carbon.* A current of considerable energy was produced by this combination. In this and in the succeeding experiments, where the use of carbon is mentioned, the kind employed was the compact carbon deposited from the gas in the retorts of the gas works. It is nearly or quite pure, and is a better conductor, both of heat and electricity, than ordinary charcoal.

45. German silver is an alloy of nickel with copper and zinc, the proportion of nickel being about twenty or twenty-five per cent. This alloy is not magnetic. Its

value in thermo-electric combinations has only recently been observed. It will be used in many of the thermo-electric instruments, to be hereafter described. German silver is positive to all the metals that have been tried, even to nickel itself; with the exception of bismuth, to which it is negative.

Carbon and Silver, or Iron. In these combinations, and also with antimony, the carbon is positive, the current being rather feeble.

46. The deflections given in the following table admit of comparison with each other to a considerable extent, though not so strictly as if wires of the same size had been employed in all the experiments. It must be remembered, too, that as the needle approaches the extreme angle of deflection 90° , a much greater increase of the current is required to carry it a few degrees farther towards 90° than when it is near the zero. Hence, a deflection of 40° does not indicate a current of half the power of one of 80° , but considerably less. Nor can momentary deflections be compared with permanent ones, in estimating the power of the current; as a current which by its first impulse causes the needle to traverse a large arc, may not be able to maintain more than a few degrees of steady deflection.

47. The wires were not soldered together, but their ends were brought in contact before the application of the heat, and kept so to the end of the experiment. With the more fusible metals, the greatest heat was employed which was consistent with their fusibility. The object was to produce the greatest current that could easily be obtained from each combination. It

will be found that there is an entire difference between the series of positive and negative metals for thermoelectricity and for galvanism.

CURRENT FLOWS THROUGH HEATED JUNCTION.		DEFLECTION OF THE NEEDLE.
From positive.	To negative.	
German Silver,.....	Antimony,.....	88°
German Silver,.....	Silver,.....	85°
German Silver,.....	Brass,.....	85°
German Silver,.....	Iron,.....	85°
German Silver,.....	Palladium,.....	85°
German Silver,.....	Copper,.....	85°
German Silver,.....	Cadmium,.....	85°
German Silver,.....	Zinc,.....	84°
German Silver,.....	Platinum,.....	81°
German Silver,.....	Carbon,.....	82°
Silver,.....	Antimony,.....	88°
Bismuth,.....	Antimony,.....	82°
Bismuth,.....	Silver,.....	78°
Bismuth,.....	Palladium,.....	85°
Bismuth,.....	Carbon,.....	85°
Bismuth,.....	German Silver,.....	83°
Platinum,.....	Carbon,.....	78°
Carbon,.....	Antimony,.....	75°

48. In some cases, the direction of the current is reversed, either by raising the heat at the junction to a high degree, or by heating one metal more than the other. The following are instances of this kind. The metal of each combination, which is positive at low temperatures, is named first. Increasing the temperature of the negative metal generally increases the amount of deflection, produced by heating the junction; while, if the higher heat is applied to the metal which is positive at moderate temperatures, a current in the opposite direction is established. The direction of the current in these combinations is, however, often uncertain, and the few experiments which have been made, afford no explanation of the cause of the changes.

49. *Iron and Platinum.* When heat is applied to the junction, or to the platinum a little one side of it, a deflection of about 50° is obtained; when to the iron near the junction, or when the junction itself is raised to a red heat, the direction of the current is immediately reversed, it now flowing from the platinum to the iron, and the needle is deflected 60° or 70° in the opposite direction.

50. *Copper and Iron.* With fine wires the current is feeble, with large ones tolerably powerful. The deflection is increased by heating the iron near the junction. When the junction is raised to a red heat, the current is reversed, and still more readily when the heat is applied to the copper near it.

Silver and Iron. Deflection considerable. On heating the silver, an energetic current ensues in the opposite direction; also, in a less degree, by raising the junction to a red heat.

Brass and Iron. Current moderate; reversed at a red heat, and still more effectually by heating the brass.

Zinc and Iron. Current moderate, and on heating the zinc near the junction to its melting point, changes its direction.

51. *Platinum and Silver.* Deflection 70° . On heating the platinum a strong current flows in the opposite direction.

Brass and Silver. The current is reversed at a red heat, or by applying the heat to the brass, near the junction.

52. In *quantity*, the thermo-electric current much resembles a feeble galvanic current. In *intensity*, it is

somewhat less. In a single galvanic pair, electricity is set in motion in a certain direction, and cannot return in the same path to the zinc, from which it proceeded, without passing through the fluid between the plates, which is a poor conductor. It is, therefore, partially, though very imperfectly, insulated. In a thermo-electric pair, the electricity is set in motion from one of the metals to the other, through the metallic junction. Here there is no insulation. The current flows through a perfect conductor, and can only be the excess of the force which sets the electricity in motion over its constant effort to return to equilibrium. It is probably for this reason that the intensity of thermo-electricity is less than that of galvanism.

Exp. 3.—A single galvanic and thermo-electric pair were taken, each of which deflected the needle 75° , permanently. The galvanic current was then made to flow through a hundred feet of fine steel wire 1-150 of an inch in diameter. From the poor conduction of the wire, the needle was only deflected 60° . By experiment it was found that the thermo-electric current deflected the needle 60° , when it was passed through only fourteen feet of the wire. As the conducting power of a wire is in proportion to the intensity of the current, some estimate may therefore be made of the relative intensity of the two currents by the respective numbers 100 and 14.

53. In soldering the wires or plates together, they are not usually connected in a straight line, but at an acute angle with each other. If several of these single pairs be associated together consecutively, that is, by connecting the German silver of the one to the brass of the next, or the bismuth of one to the antimony of the next, and so on, we have a thermo-electric battery, in

which the powers of thermo-electricity are much exalted. It will be understood that in these cases there is German silver and brass alternately, or bismuth and antimony alternately, &c., throughout the whole series. For the sake of compactness, the wires or plates are laid side by side, and soldered by their alternate ends, while they are insulated or separated from each other by paper or pasteboard, which prevents all passage of electricity from one to the other.

Fig. 14.

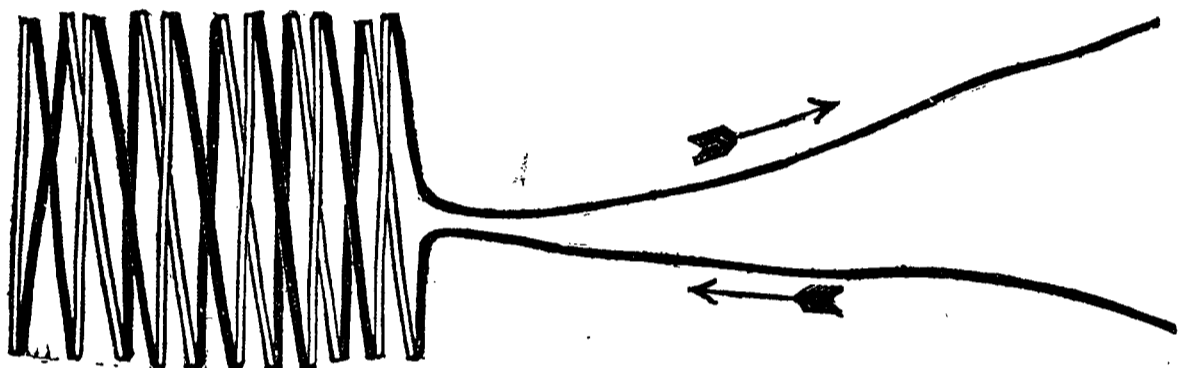

54. Fig. 14 represents a series, consisting of eleven pairs of German silver and brass wire, arranged in two rows, one behind the other. When several pairs are connected in this manner, it is necessary that the junctions should be somewhat larger than in the case of a single pair. Then, the slighter the junction the better; but as the current has to flow through all the junctions in a series of pairs, the electricity generated would scarcely be conducted through them at all, were they all imperfect. By heating the junctions of the wires on one side of the series with a spirit lamp, a current is produced which increases or diminishes as the heat is applied, depending altogether for its existence on the difference of temperature in the opposite junctions of the wires. By grasping the junctions on one side in the

fingers, even the warmth of the hand produces a sensible effect. It is evident that, if the junctions on both sides of the series were heated, currents would be produced in opposite directions, which would neutralize each other.

55. Fig. 15 represents a battery, consisting of sixty pairs of bismuth and antimony plates, each three inches

Fig. 15.

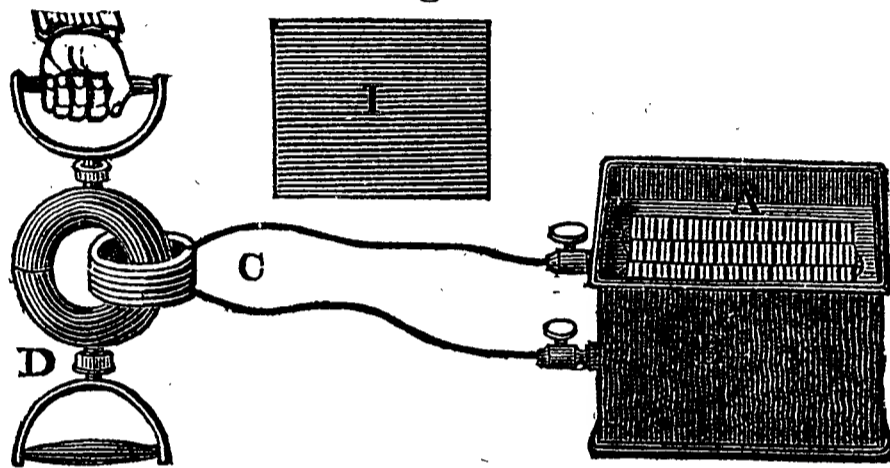

long, three-fourths of an inch broad, and one-fourth of an inch thick. They are arranged side by side, in an exterior case, so that one series of junctions underneath the battery may be heated by the radiation of a hot iron plate, I, shown separately in the cut, while the opposite junctions seen at A are kept cool by water or ice placed in the receiver, which forms the upper part of the battery. A still greater depression of temperature is produced by a mixture of snow or pounded ice with half its weight of common salt. In order to make a water-tight receiver, the plates are cemented into the case with plaster. Refrigeration at one end of the pairs, as would be anticipated, is found to produce a current in the same direction, and equal to that which would be produced by a similar excess of heat at the other end; difference of heat at the different ends, however produced, being

the occasion of the current. By associating both of these causes in this battery, there is a corresponding increase of power. As the metals employed in the battery are fusible, the radiant heat of the iron ought never to exceed 300° Fahrenheit. The iron plate being laid upon a large tile, the battery is placed over it, the iron being pretty near the ends of the bars, but not in contact with them.

56. The terminal plates of the battery are connected with two binding screw cups, passing through the exterior case. In the cut, the battery is seen in connection with an apparatus to be described in chapter II, sect. 2, by which the magnetizing power of the current is shown. The ends of the coil of insulated wire C being fixed in the cups, the current is obliged to traverse the coil, and the two semicircular armatures of iron seen at D, are held together by the magnetism thus induced, with so much force as to require a weight of forty or fifty pounds to separate them. This battery has sufficient power to give shocks and sparks, and produce various magnetic phenomena, with the appropriate apparatus, which will be described hereafter, when the principles on which those effects depend have been explained.

57. A thermo-electric battery of considerable energy can also be constructed of strips of German silver and brass. It will bear contact with red hot iron, and is very compact. This has not yet been fully brought to perfection; so that a comparison cannot be instituted here between its powers and those of the bismuth and antimony battery described in sect. 55.

58. By forming a bundle or small battery, consisting

of many pairs of wires, the slightest increase of heat at one end produces a sensible current of electricity. This forms an instrument for measuring heat far more delicate than any other which has been contrived. It has been used in ascertaining the temperature of insects, and of various parts of the animal system.

59. In thermo-electricity, an electrical current is produced by heating unequally the opposite ends of metallic plates, associated in a thermo-electric series. The converse of this is found true. If a galvanic current is made to pass through the same series, the opposite junctions will acquire heat on the one side and lose it on the other.

60. Fig. 16 represents an instrument for showing the simultaneous production of heat and cold by the galvanic current. It

Fig. 16.

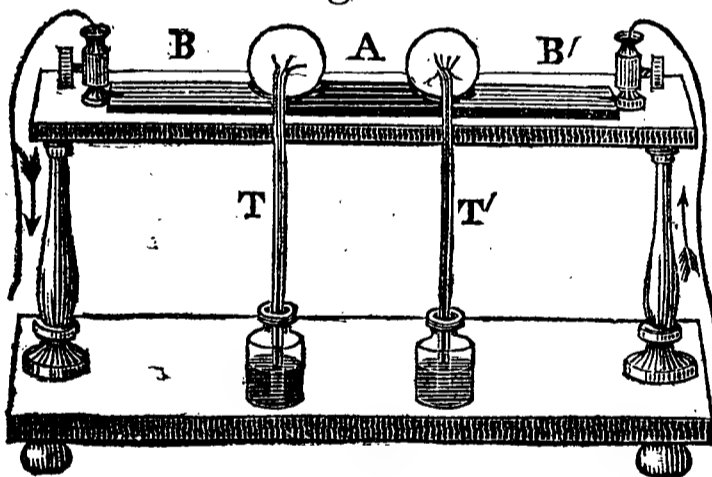

consists of three bars, two of bismuth and one of antimony, arranged as seen in the figure, where the antimony is shown at A, and the two bars of bismuth at B B', the bars being soldered together under the bulbs of two air thermometers, T and T'; a little cavity being made to receive the bulb of each thermometer; a drop of water is put in each cavity, in order to facilitate the conduction of heat from the metals to the thermometers.

The galvanic current being sent through the metals, in the direction indicated by the arrows, from the bismuth B', through the antimony, to the other bar of bismuth,

and thence back to the battery, at the junction of A with B', cold is produced, as will be indicated by the thermometer T', and heat at the junction between A and B, as the thermometer T will show; by reversing the direction of the battery current, the effect on the two thermometers will be reversed. The elevation of temperature produced is always greater than the depression; this difference is probably due to the low conducting power of the metals for electricity, which causes them to become slightly heated by the current, a phenomenon altogether distinct from the heating of the junction by it. It will be observed in the figure that the current has the same direction as that which would be produced, were the battery removed, by the application of heat at the junction of A with B', or of cold to that between B and A; the current which produces heat flowing in the opposite direction to the current which would be produced by it.

IV. ANIMAL ELECTRICITY.

61. The torpedo, on the shores of Europe, the gymnotus, or electrical eel, inhabiting the fresh waters of South America, and the silurus electricus, living in the rivers of Africa, have been celebrated for their powers of producing electricity. As it appears to be dependent on will, although associated with certain organs, it has received the name of *animal electricity*. It possesses considerable intensity, and is capable, to a certain extent, of producing all the magnetic phenomena. The production of electricity by animal life, has been occasionally noticed under other circumstances.

MAGNETISM.

I.

DIRECTIVE TENDENCY OF THE MAGNET.

I. IN REFERENCE TO ANOTHER MAGNET.

62. **ATTRACTIONS AND REPULSIONS.**—The effects produced by the opposite poles of a magnet, though in some respects similar, are in others contrary to each other; the one attracting what the other repels. Poles of different magnets, of the same name, that is, both north or both south, are found to repel, while those of an opposite name attract each other.

Exp. 4.—Let N. S. (fig. 17,) be a magnetic needle poised upon a pivot. Let N be the north and S the south pole. Then bring near to its north pole the north pole of the bar magnet M. The north pole of the needle will be repelled, causing the needle to assume the position *r r*. If now the magnet M is reversed, so that its south pole is made to approach the north pole of the needle, the latter will be attracted, and the needle will be drawn to the position *a a*. The

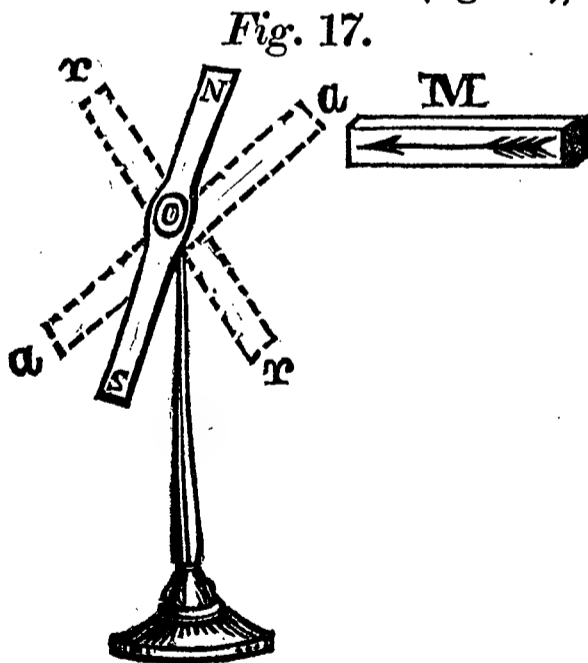

south pole of the needle, on the contrary, would be *attracted* by the north pole of M, and *repelled* by its south pole.

63. The intensity of the attraction or repulsion exerted between two magnetic poles, varies in the inverse ratio of the square of their distance ; that is, if the distance of the poles is doubled, the force with which they attract or repel each other is reduced to one quarter of its previous amount ; if their distance is trebled, to one ninth ; and so on.

64. These attractions and repulsions are not affected by the interposition of glass or metal, or any substance whatever between the two magnets ; unless the interposed body is itself susceptible of magnetism.

65. Whenever a piece of iron, as B (fig. 18) is brought near to one of the poles of a magnet, M, the iron

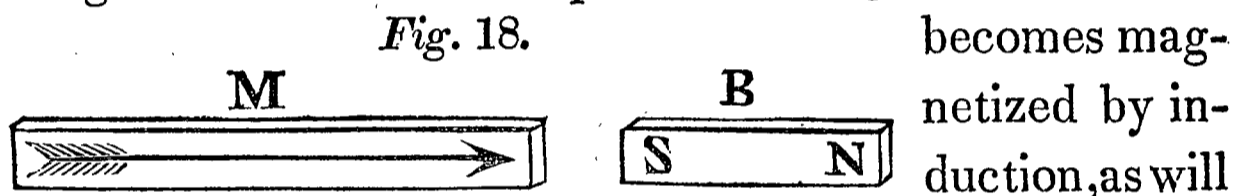

be explained hereafter, chapter II, sect. 1 ; and the extremity nearest to the pole acquires an opposite polarity to that of the pole, while the end farthest off acquires the same polarity. Thus, in the figure, the point of the arrow indicates the north pole of the magnet, and the extremity S of the iron bar will acquire a south polarity. It follows from this, that it is only that part of a fragment of iron nearest to the pole of a magnet, which can be attracted by that pole, while the part most distant must be repelled. If the fragment of iron has any considerable length in proportion to its breadth, the end which is repelled will be at such a distance from the influence of the magnet that its repulsion will be overpowered by the attraction of the extremity which is near it. If, however, the fragment is very short, so that the

repelled pole is brought very near to the magnet, the repulsion will be proportionally stronger, and the attraction will be neutralized to a considerable extent; and, finally, if the fragment of iron is made of such a form as to bring the two opposite poles as near together as possible, so as to expose them both nearly equally to the influence of the pole of the magnet, the attraction will become scarcely perceptible. This may be shown very satisfactorily in the following manner.

EXP. 5.—Let M (fig. 19) be the south pole of a bar or horse-shoe magnet, and A a piece of sheet iron, somewhat smaller than the end of the magnet. When this

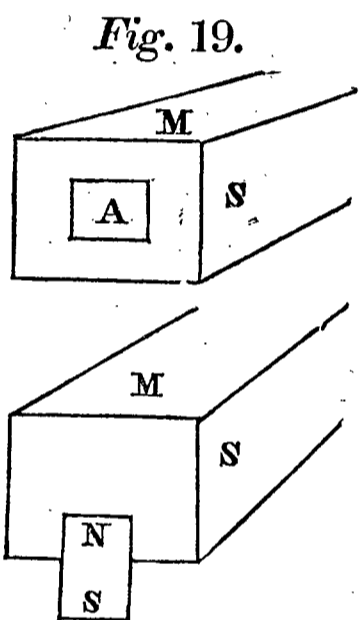

iron plate is placed in the position represented in the upper figure, the surface next the pole of the magnet will acquire north polarity, while the opposite surface will become south; and the iron being thin, the two surfaces are both so near to the pole of the magnet that one is repelled nearly as much as the other is attracted. The thin plate will be found to adhere to the pole with a very slight force, and will tend to slip down into the position represented in the lower figure. In this position it will be much more strongly attracted; for the two opposite *ends*, instead of the two opposite *surfaces*, will become the poles, and the end in contact will be attracted, and the remote end will be repelled. The same effect will be produced if the plate is applied to the pole of the magnet by its edge, instead of by one of its surfaces; by this means the repelled pole of the plate is removed to a distance from the magnet, leaving the latter to attract the other pole, with a less interference from the counteraction which operated in the former case.

66. MAGNETIC TOYS. Various magnetical toys are constructed to exhibit the effects of the attractions and repulsions, described in § 62 such as swans, ships, fishes,

and other figures, with magnets concealed within them, and intended to float upon the water. When thus floating, they may be attracted or repelled over the surface of the water at pleasure by means of another magnet held in the hand.

67. **FLOATING NEEDLE.** A very fine and perfectly dry sewing-needle, being previously magnetized and then laid carefully upon the surface of water, will float, and being thus at liberty to move freely in any direction, may be conveniently used to show the above-described attractions and repulsions. A larger needle will answer equally well, if passed through a small piece of cork, that it may float.

68. **ROLLING ARMATURE.** This apparatus consists of a compound horse-shoe magnet and an armature consisting of an iron wire whose length is a little greater than

Fig. 20.

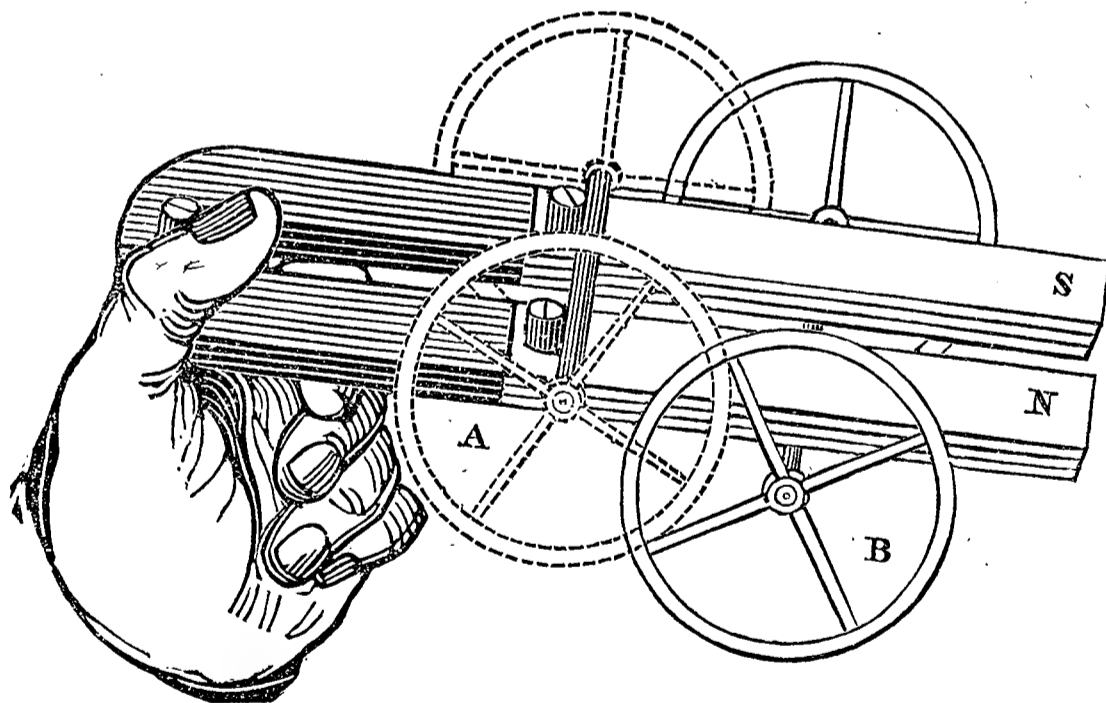

the breadth of the magnet, so that when applied to it the extremities may project a little beyond its sides. To each of these extremities a small fly-wheel is attached.

This armature is then placed across the magnet, at some distance from the poles, as seen at A, and the magnet is held in such a position, with the poles downward, that the armature may roll towards them. When it reaches the poles, the magnetic attraction for the iron axis will prevent its falling off, while the momentum acquired by the fly-wheels will carry it forward and roll it some distance up the under side of the magnet to B in the figure; and by varying the inclination of the magnet N S, the armature may be made to roll from A to B, and from B to A, at pleasure.

69. It results from what was said in § 65, that the action of a magnet upon a mass of iron is not simply an attraction or a repulsion of it as a mass, causing it merely to approach or to recede; but that there is a complicated reciprocal action between the poles of the magnet and those which the mass of iron has assumed.

EXP. 6.—Let M (fig. 21) be a magnet, the position of the north pole being indicated by the arrow. Now if the small bar of iron S N, suspended by a thread, is placed in the position marked 1, it becomes magnetized by induction from the fixed magnet, so

Fig. 21.

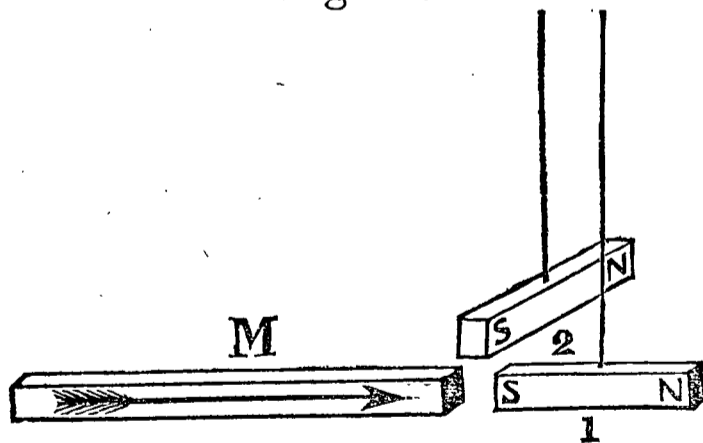

that the extremity S will be attracted by the north pole of the magnet, and the extremity N will be repelled by it, as has already been explained. Both these forces will conspire to retain the body in the direction represented in the drawing;

while the influence of the remote extremity of the magnet M, will be insensible. Now if the bar S N is removed to the position marked 2, the north pole of the magnet will attract the south pole of the bar, and will repel the north pole, as before; but then, on

account of the inclined position of the bar, the attractive force between the south extremity of the magnet and the north extremity of the bar will come into action; so that the north pole of the bar will be drawn towards the south pole of the magnet, and the bar will be deflected somewhat from the position which it would otherwise have assumed. This tendency of the bar to place itself in a certain determinate direction, in reference to the other magnet to whose influence it is exposed, is called its *directive tendency*.

70. This effect of the remote pole of the magnet in giving direction to the bar, will be quite decided when the suspended bar is carried still farther from the north

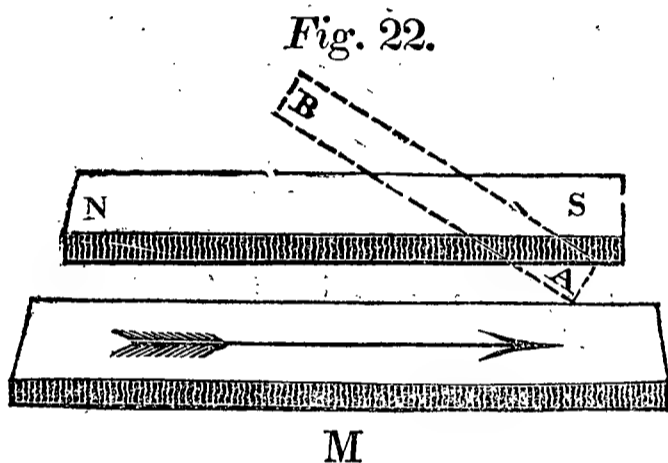

pole: for example; nearly opposite the centre of the magnet, as in fig. 22, where M represents the magnet as before. Now in this case, if the suspended bar were acted

upon solely by the north pole of the magnet, it would assume the position A B; for the pole S being attracted, and the pole N repelled, the bar would place itself in a line directed towards the north pole of the magnet. But instead of this, the bar is in such a position that the south pole of the magnet acts powerfully upon it also; and if the magnetic forces of the two poles of the magnet are of equal intensity, the south pole will act upon the end marked N, as strongly as the north pole acts upon S; and the suspended bar will assume the position marked N S, that is, parallel to the magnet.

71. The directions thus assumed by an iron rod brought near a magnet depend upon the much greater facility with which the bar receives polarity in the direc-

tion of its length than transversely. Thus if the bar is placed on one side of the magnet, at right angles to it, and opposite its middle, it would remain in this position instead of turning itself parallel to the magnet, were it not for the difficulty of developing the two polarities on its opposite sides.

72. A steel magnet does not experience that change in the distribution of its polarity, by altering its position with regard to the fixed magnet, which the iron bar does. Hence the experiments above described are better performed with a *magnetic needle*, which may be suspended by a thread, or, which is better, supported by a pivot, and thus held in various positions near to a bar magnet. The needle being a permanent magnet, and having been powerfully magnetized by the process to which it has been subjected in the manufacture, the action of its poles will be more decided than that of the poles of a bar of iron magnetized only by temporary induction.

Fig. 23.

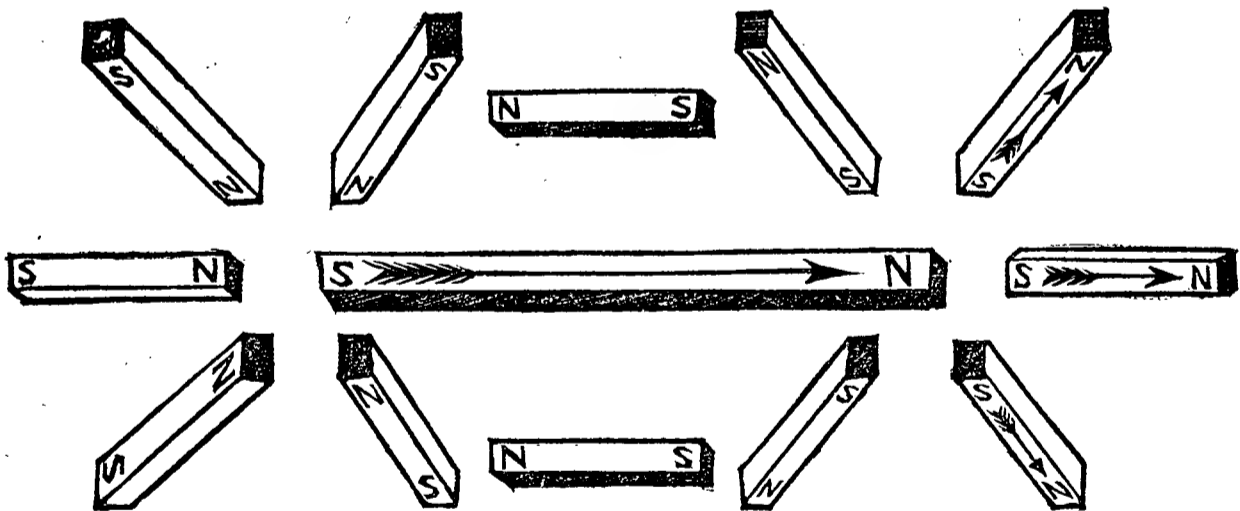

By passing such a needle carefully around a bar magnet it will be found that it will assume positions in relation to it, as represented in the above cut, fig. 23.

73. These effects, produced by the combined attrac-

tions and repulsions of the magnetical poles, may be also rendered sensible in a very satisfactory manner by the following experiment.

EXP. 7.—Spread a thin covering of iron filings or ferruginous

Fig. 24.

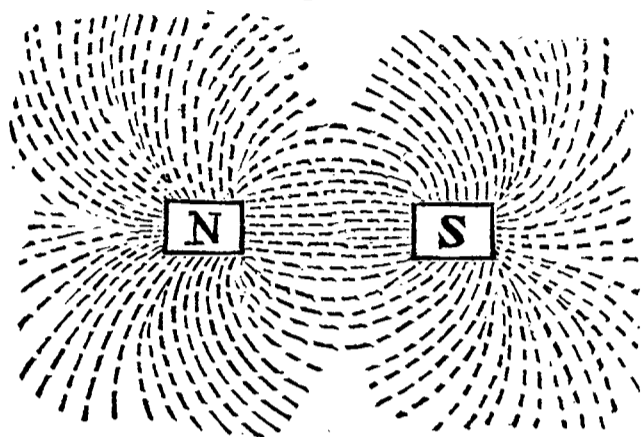

sand over a sheet of paper, and place a powerful horse-shoe magnet vertically beneath it, with the poles very near to the paper. The dotted lines in the cut (fig. 24) show the arrangement which the particles of iron will assume. Each one

becomes a magnet with its two poles, and connects itself with those adjoining it so as to form curved lines of a peculiar character. This experiment may be performed in a still more satisfactory manner, by supporting the paper, with the magnet in contact with its under surface, and then showering down iron sand or iron filings from a sand-box held some inches above. The particles of iron, as they strike the paper can thus more readily assume the positions to which they tend under the magnetic influence.

74. The lines formed by the filings afford a good experimental illustration of what are called *magnetic curves*, that is, the curves into which an infinite number of very minute magnetic needles suspended freely would arrange themselves, if placed in all possible positions about a magnet. When the particles are very small, the *attractive force* exerted upon them by the magnet, being the difference of its action upon the two poles of each particle, is exceedingly slight; while the *directive force* is very considerable. The direction assumed by each particle, and consequently the form of the magnetic curve, connecting any point on one half of the magnet, with the corresponding point of the other half, is de-

ducible on strict mathematical principles from the laws of magnetic attraction and repulsion. The curvature of the lines is due to the combined action of the two poles of the magnet. If only one pole acted on the minute particles, they would arrange themselves in straight lines, diverging in all directions from the pole, like radii from the centre of a sphere. This may be partially shown by placing a bar magnet perpendicularly under the paper which is strewed with filings, with its upper pole close to the sheet.

II. IN REFERENCE TO A CURRENT OF ELECTRICITY.

75. It was discovered by Prof. Ørsted, of Copenhagen, in the year 1819, that a magnet, freely suspended, tends to assume a position at right angles to the direction of a current of electricity passing near it. This may be made manifest as follows.

EXP. 8.—Let N S, fig. 25, be a magnetic needle poised upon a pivot so as to allow of a free horizontal motion, and W R a wire passing directly over and parallel to it. Of course, the direction of the wire must be north and south, as the needle will necessarily assume that direction, on account of the influence of the earth. If now the extremities of the wire are put in connection with the poles of a galvanic battery, in such a manner as to cause a current of electricity to pass through it, the needle N S will be deflected and will turn towards the position *a b* or *c d*, according to the direction of the current of positive electricity, whether from

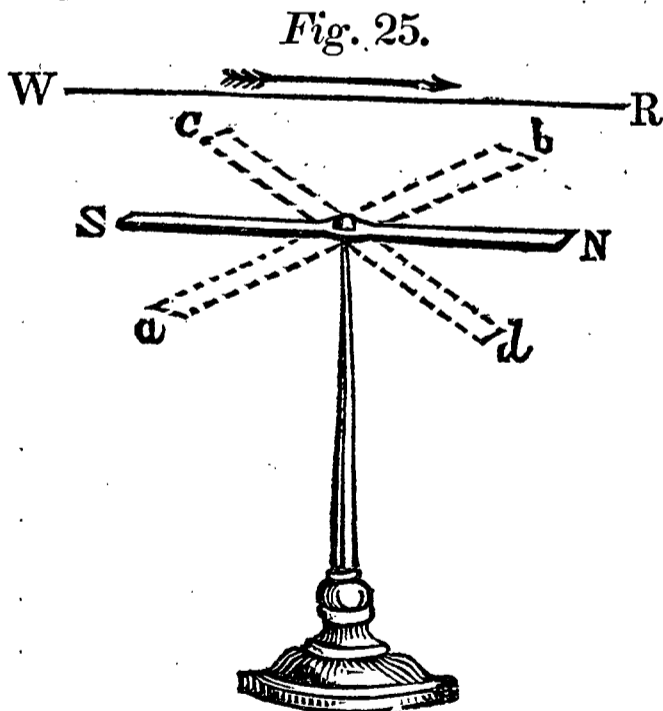

wire passing directly over and parallel to it. Of course, the direction of the wire must be north and south, as the needle will necessarily assume that direction, on account of the influence of the earth. If now the extremities of the wire are put in connection with the poles of a galvanic battery, in such a manner as to cause a current of electricity to pass through it, the needle N S will be deflected and will turn towards the position *a b* or *c d*, according to the direction of the current of positive electricity, whether from

W to R, or from R to W. If the wire be placed in the same direction below the needle, the deflections will be the reverse of those produced by the same current when flowing above. If the positive current is passing from south to north in the wire, as shown by the arrow in the cut, the north pole of the needle will turn to the west, if it be below the wire; and to the east if above it.

76. In these cases the needle will not be deflected so far as to assume a position really at right angles with the wire, on account of the influence of the earth, which still acts upon the magnet, and tends to draw it back to its original position. It will accordingly come to rest in a state of equilibrium between the forces, in a direction intermediate between a line at right angles to the wire and that of the needle when controlled by the magnetism of the earth alone.

77. The same experiment may be performed with the dipping needle, the wire being placed parallel with the needle. By thus varying the positions of the wire and the needle, it will be found that in all cases the needle tends to place itself at right angles with the wire, and to turn its north pole in a determinate direction with regard to the wire.

78. The action of a conducting wire upon a magnet exhibits in one respect a remarkable peculiarity. All other known forces exerted between two points, act in the direction of a line joining these points; such is the case with the electric and magnetic actions separately considered. But the *electric current* exerts its magnetic influence laterally, at right angles to its own course. Nor does the magnetic pole move either directly towards or directly from the conducting wire, but tends to revolve around it without changing its distance. Hence the force

must be considered as acting in the direction of a *tangent* to the circle in which the magnetic pole would move. It is true, that in many positions of the magnet with regard to the wire, apparent attractions and repulsions occur; but they are all referable to a force acting tangentially upon the magnetic poles, and in a plane perpendicular to the direction of the current. This peculiar action may be better understood by means of a figure.

79. Thus, let $p n$ (fig. 26) be a wire, placed in a vertical position, and conveying a current downwards (p being connected with the positive pole of the battery).

Fig. 26.

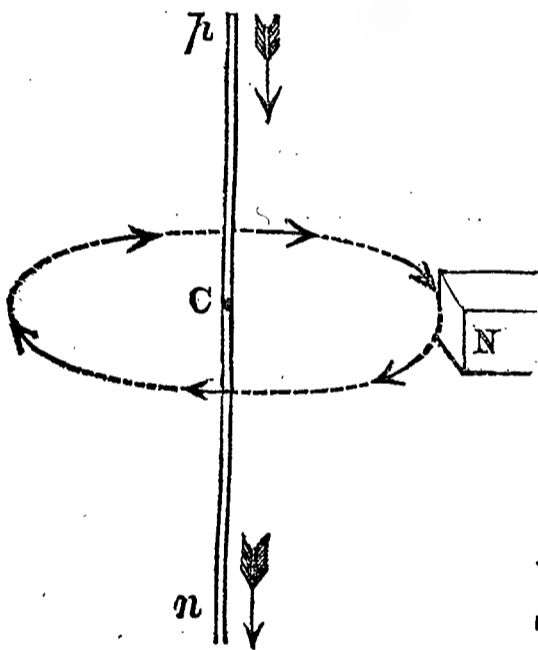

Now suppose the north pole of a magnet N to be brought near the wire, and to be perpendicular to any point C . If free to move, the pole will revolve around C as a centre in the direction indicated by the arrows in the cut; that is, in the same direction as the hands of a watch, when its face is upwards.

The plane of the circle which the pole describes is horizontal. On causing the current to *ascend* in the wire, the pole will rotate in the opposite direction. If the wire be placed in a horizontal position, the plane in which the pole revolves will, of course, be vertical. The actions of either a descending or an ascending current upon the south pole are exactly the reverse of those exerted on the north pole. If the wire is movable and the magnet fixed, the former will revolve around the latter in a similar manner, and in the same

directions. Thus, a wire conveying a descending current tends to rotate round the north pole of a magnet, in the direction of the hands of a watch. In the experiment given in § 75, no revolution occurs, because the current, acting at once on both poles, tends to give them motion in opposite directions; so that the magnet comes to rest in a position of equilibrium between these two forces, across the wire. It will be shown hereafter (chap. II, sect. 2) that, by confining the action to one pole, a continued rotation is produced.

80. The following apparatus illustrates the directive tendency of the magnet in respect to a current of electricity.

MAGNETIC NEEDLE, HALF BRASS. In this instrument the steel needle is wholly upon one side of the point of support, and is counterpoised by a brass weight on the other side. By this arrangement the action of a current upon the pole which is situated at the centre of motion can have no influence in turning the magnet in any particular direction; and its motion will be determined solely by the action upon the other pole; no rotation, however, can be obtained. The object of the instrument is to show the *directive tendency of a single pole* with reference to the electrical current.

81. **ASTATIC NEEDLE.** A needle so contrived that its directive tendency in respect to the earth is neutralized, so that it shall remain at rest in any position, is called an *astatic needle*. It is constructed as represented in the following cut, fig. 27, consisting essentially of two needles, one above the other, placed in positions the reverse of each other in respect to their poles. Such a

system will of course not be affected by the magnetic influence of the earth, as whatever forces may be

Fig. 27.

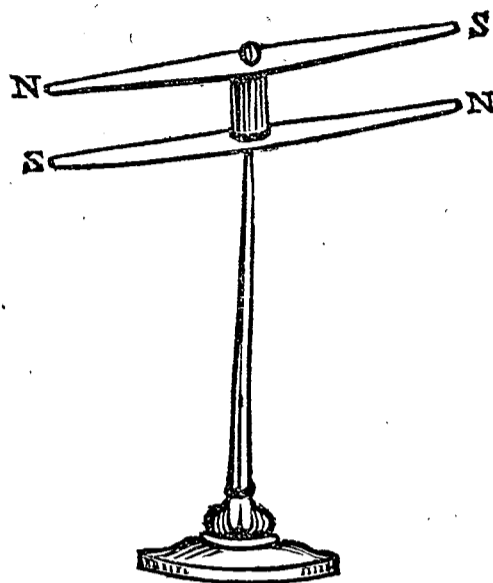

exerted upon the upper needle, will be counteracted by equal forces exerted in reverse directions upon the lower. It would be the same, indeed, with the influence exerted by the current of electricity, if the wire were to be placed in such a position as to act equally on both needles.

But by placing the wire parallel to and above the upper needle, the influence of the wire will be, of course, far more powerful upon the upper than upon the lower one, and the action of terrestrial magnetism being neutralized, the needle will assume a position at right angles with the conducting wire. If the wire be placed as nearly as possible between the needles and parallel to them, the influence of the upper side of the wire will deflect the upper needle in the same direction as the lower needle will be deflected by the action of the lower side of the wire, causing a more powerful effect.

Fig. 28.

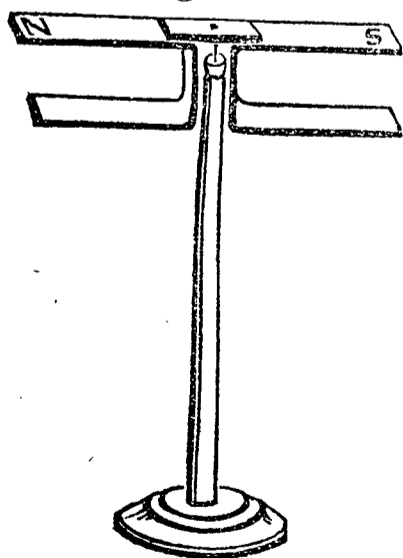

82. Fig. 28 represents another astatic needle, similar to the above, but consisting of two horse-shoe or U magnets united at the bend, so as to have their opposite poles in the same line, and delicately supported upon an agate cup. These needles need not be perfectly *astatic*, nor is it easy to make them so.

83. If the wire transmitting the electrical current, after passing over the needle, is bent and returned under it, as

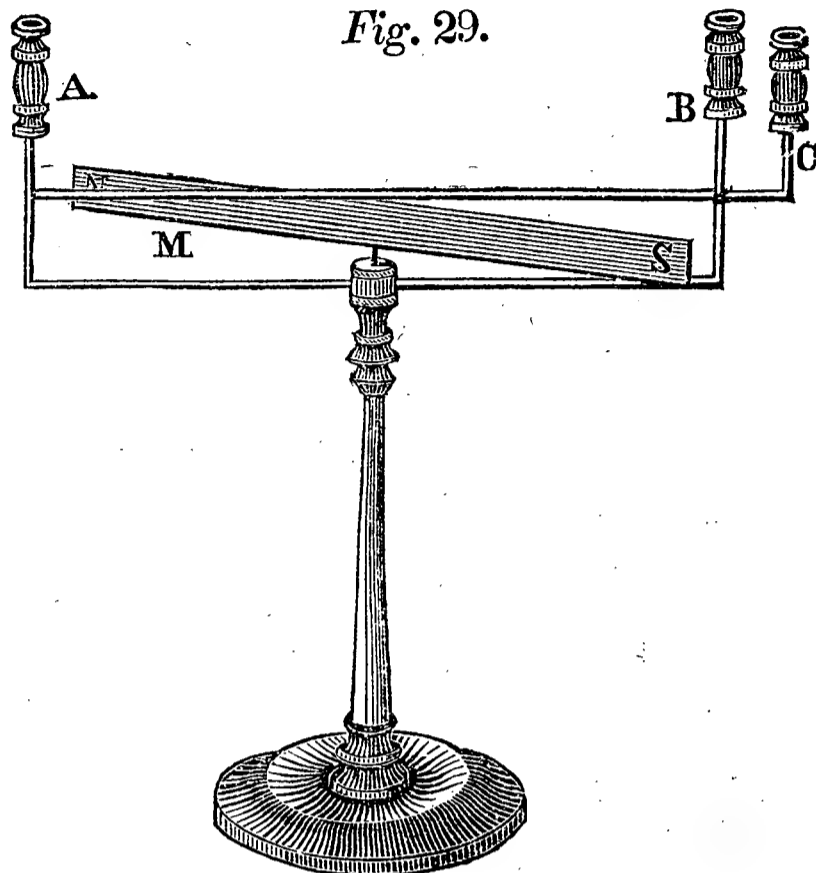

Fig. 29.

in fig. 29, it might be supposed that as the electricity which flows from C to A in the upper part of the wire, must pass in a contrary direction, in returning from A to B, below (the cup C being connected with the positive

pole of the battery, and B with the negative), the influence of the one part of the wire would neutralize that of the other, for it has already been stated that the needle is deflected to one side or the other according to the direction of the electrical current. And this would in fact be the case, if the returning part of the wire were upon the same side of the needle with the other part, and at an equal distance from it. But a wire transmitting an electrical current, when passing *below* the needle, will produce an effect the reverse of that produced by one passing *above*, if the current in both cases flows in the same direction. And of course it follows, that if the direction of the electric current is reversed in the wire which passes below, it will exert a force auxiliary, and not antagonist, to that of the wire passing above. This is the case with the arrangement here represented.

The electric current flows, it is true, in a contrary direction, below the needle, but then it is on the opposite side of it, and therefore the effect produced by the lower portion of the wire will conspire with that of the upper part. It should be stated, that the two portions of the wire are not allowed to touch each other where they cross, but are insulated at that point by some non-conductor of electricity, as by being wound with thread.

84. The vertical portions of the wire also aid in deflecting the needle; as may be shown by connecting both the cups B and C with one pole of the battery by two wires of equal length and thickness, and the cup A with the other pole (say the positive). The current will then be divided into two portions very nearly equal, both flowing in the same direction and at the same distance from the magnet M, but one below and the other above it. Now if the horizontal portions of the wire alone acted on the needle, it would remain unaffected; but it will be found to be deflected to a considerable extent by the current which is descending in the vertical portion of the wire near A, and ascending in that below B, as these conspire in their influence.

85. THE GALVANOSCOPE OR GALVANOMETER. Instruments of a variety of forms are constructed on the above principles, and are called *galvanoscopes* or *galvanometers*, as they serve to indicate the presence of a current of electricity and in some degree to measure its quantity. If the wire is carried many times around the needle, as in fig. 30, the power of the instrument is much increased, as each turn of the wire adds its influence; provided the wire is not so long or of so small a size as

to be unable to convey the whole of the current. The instrument thus becomes a delicate test of the presence of a current of electricity. The coil of wire is supported

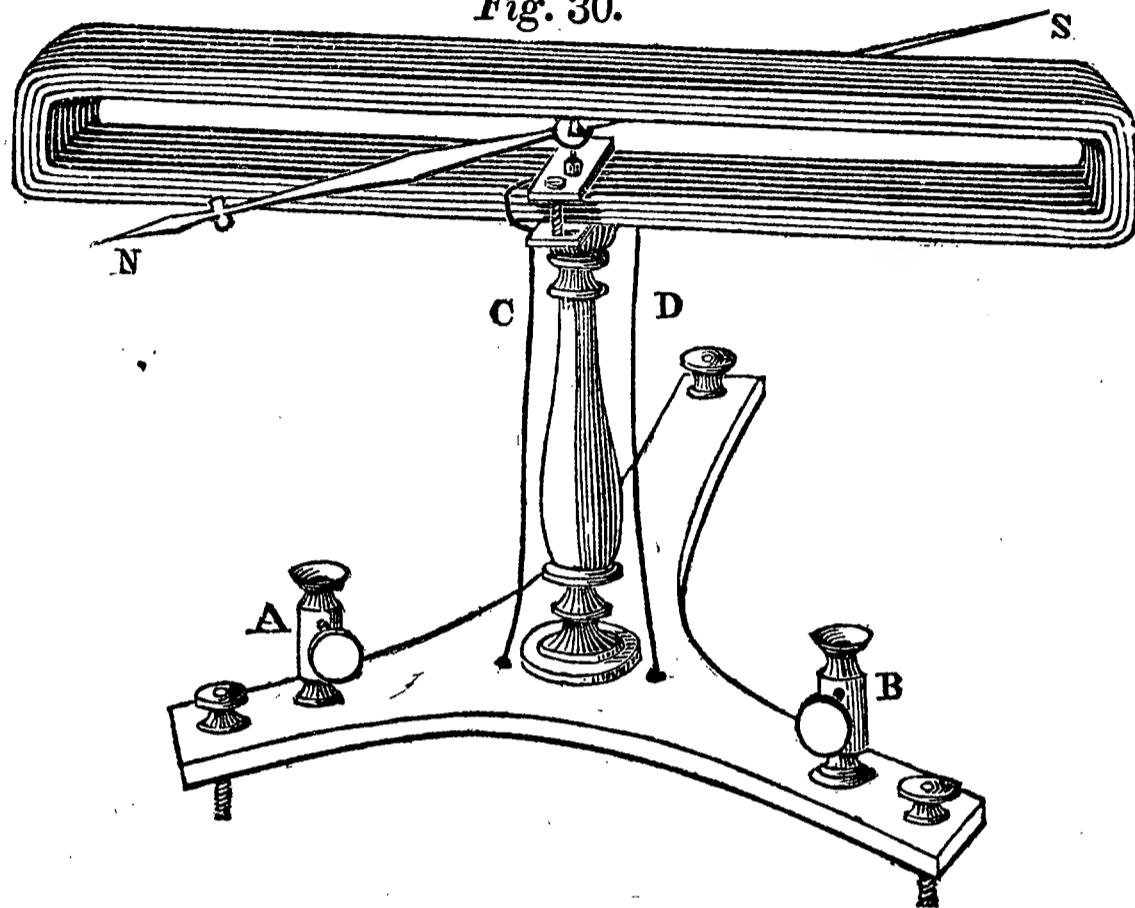
Fig. 30.

on a tripod stand, with leveling screws; the ends C and D of the wires being connected with the binding screw cups A and B.

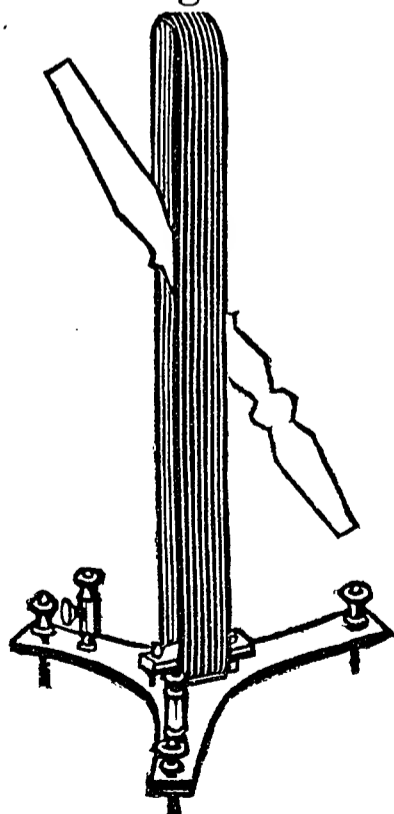
Fig. 31.

86. UPRIGHT GALVANOMETER.

In this instrument, represented in fig. 31, both the coil of wire and the needle are placed in a vertical position, the north pole being made a little heavier, in order to keep the magnet perpendicular. When a current is passed through the coil, the deflection is towards a horizontal position. The needle is made of large size, for the purpose of exhibiting the deflections before an audience.

87. GALVANOMETER WITH ASTATIC NEEDLE. This instrument is similar in construction to the preceding, except that the needle is nearly astatic. The slight degree of directive tendency which is allowed to remain becomes the measure of the force of the electric current, as the angle of deflection from the north and south line shows how far this resistance is overcome. This instrument may be made so extremely delicate in its indications, that if two fine wires, one of copper and one of zinc, are connected with it, and their ends immersed in diluted acid, or even placed in the mouth, it will be very perceptibly affected. Before proceeding to experiment with any galvanometer, it should be so placed that the direction of the coil may coincide with that of the needle, as this is the position of greatest sensibility.

88. The galvanometer is a measurer of what is called the *quantity* of electricity, but takes no cognizance of *intensity*. Mechanical electricity which possesses great intensity and but little quantity, very slightly deflects the needle of the galvanometer. The current from one galvanic pair influences the needle powerfully, the quantity being very great, and the intensity small. If a hundred pairs be connected together in a single series, the intensity is increased a hundred fold, but the quantity remains the same, and the needle is but little more deflected than by one pair. The reason that there is any difference in this respect is, that when the electricity is of high tension, the wire of the galvanometer obstructs the current less, and more actually passes through it. In thermoelectricity, with a single pair, the intensity is less in proportion to the quantity than with a single galvanic pair, and the current is strongly indicated by the galva-

nometer. The amount of decomposing power in a current of electricity is always exactly as its quantity. The galvanometer indicates therefore the electromagnetic and the decomposing capacity of a current of electricity. An intense electrical current decomposes more easily than one of little intensity, but the amount of matter decomposed is proportional merely to the quantity of the current. Besides the galvanometers in which a magnetic needle is used, the gold-leaf galvanoscope, an instrument possessing great delicacy in its indications, will be described hereafter.

III. IN REFERENCE TO THE EARTH.

89. The exact period of the discovery of the directive tendency of the magnet with respect to the earth, and of its employment as a guide to the mariner, cannot be ascertained with certainty; but it was used for this purpose by the nations in the north of Europe, at least as early as the twelfth or latter part of the eleventh century.*

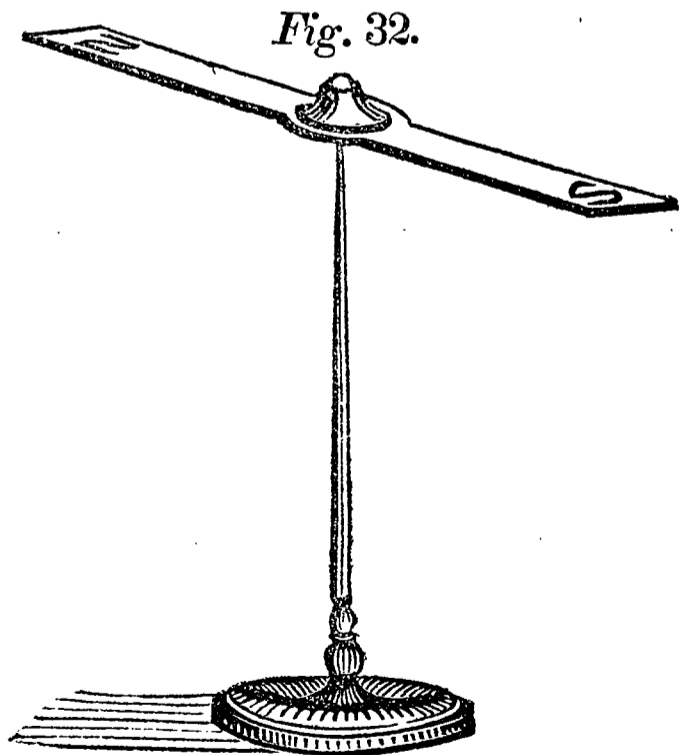

90. Fig. 32 represents a magnet poised upon a pivot so as to turn horizontally. This arrangement is essentially on the same principle as the compass-needle; the latter, however, being fixed to a circular card on which the cardinal points are marked.

* The Chinese claim to have known the polarity and use of the magnet in the second century or earlier.

91. It is found that a magnetic needle, so suspended as to allow of a free horizontal motion, spontaneously assumes a direction nearly north and south; and if displaced from this position returns to it after a number of oscillations.

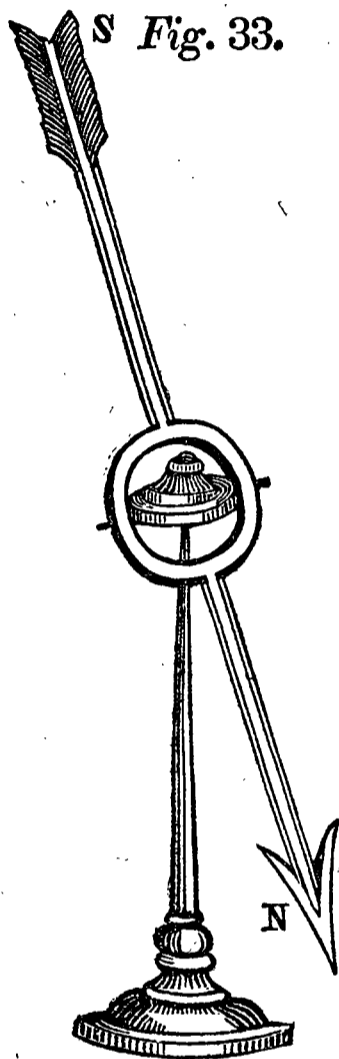

92. If the needle be suspended so as to have freedom of motion in a vertical direction, it is found not to maintain a horizontal position, but one of its poles (in this hemisphere the north) inclines downwards towards the earth. At the magnetic poles of the earth the direction of the needle would be vertical; but the inclination diminishes as we recede from the poles towards the equator, and at the magnetic equator, which is near the geographical one, the needle becomes horizontal. A needle properly prepared for exhibiting this inclination, is called a *dipping needle*.

93. Fig. 33 represents a dipping needle whose mode of suspension allows of its turning freely in any direction. It is fixed by means of a *universal joint* to a brass cap containing an agate, which rests upon the pivot. The usual arrangement allows only of motion in a vertical plane, the needle having an axis passing through its middle at right angles to its length, which axis is supported horizontally. The small needles shown in fig. 34 are suspended in this manner. Sometimes a vertical graduated circle is added, to measure the angle which the needle makes with the horizon. In using a needle

whose motion is confined to a single plane, it must be so placed that this plane may be directed north and south, coinciding with the plane of the magnetic meridian. A dipping needle, before being magnetized, should be as equally balanced as possible, so as to remain at rest in any direction in which it may be placed; a high degree of accuracy is, however, difficult of attainment.

94. The dipping needle will assume, also, in various

Fig. 34.

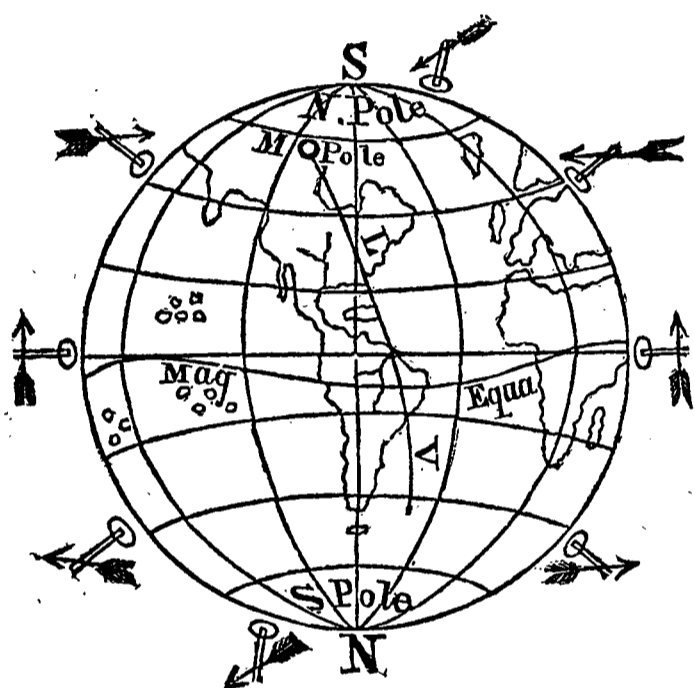

latitudes the directions exhibited in the annexed diagram, fig. 34, where the point of the arrow indicates the north pole and the feather the south pole of the needles placed around the globe. The angle which the needle makes with the horizon at any place is

called the *dip*, at that place. The tendency of the needle to dip is counteracted in the mariner's and surveyor's compasses, by making the south ends of needles intended to be used in northern latitudes, somewhat heavier than the north ends.

95. In fig. 34, M represents the North American magnetic pole near S the north pole of the earth. The line L V is nearly the present *line of no variation*, (see § 98) and the curved line at the centre is the magnetic equator, or where the dip is at zero, and the direction of the dipping needle is the same as that of the horizontal needle.

96. By comparing the directions assumed by the needle in its various positions in respect to the earth, as represented in fig. 34, with those assumed by a magnet in reference to another magnet, as illustrated in sect. 72, it will be found that there is a great analogy between them. This analogy led to the opinion, which was for a long time entertained, that the earth was itself a magnet, or that it contained within it large magnetic bodies, under the influence of which the magnetic needle assumed these various directions; just as a small needle assumes such directions when brought in various positions near to a bar magnet.

97. But there is another mode of accounting for the directive tendency of the magnet in respect to the earth; and that is by supposing, instead of magnetized bodies within the earth, lying parallel to the direction of the needle, currents of electricity passing around the earth, within it, but near the surface, at right angles with that direction. This would identify the directive power of the needle in respect to the earth, with its directive tendency in regard to a current of electricity, as described under the last head, instead of with respect to another magnet. And this is, in fact, the view which philosophers are now inclined to take of the subject. The theory, however, is yet unsettled; and in fact all these three forms of directive tendency may hereafter be shown to be identical. In the mean time the phenomena being distinct, they may properly be arranged in different classes.

EXP. 9.—Lay a fine sewing-needle, unmagnetized, upon the surface of water, where, if it is perfectly dry, it will float, and it will be found that it will lie nearly indifferently, in any position.

Then magnetize it, by touching it with any magnet, and replace it upon the water, in a direction east and west. It will immediately turn and assume a position in the magnetic meridian, that is, nearly north and south.

EXP. 10.—Place a magnetic needle upon its pivot so that its north pole turns towards the north. Then take it off its pivot and draw the north pole across the north pole of a strong magnet, and the south pole of the needle across the south pole of the magnet. On replacing it upon its pivot, it will be found that the pole which was previously north will now turn towards the south, and the south pole towards the north. In this way the poles of the needle may be reversed at pleasure.

EXP. 11.—To prove that the inclination of the dipping needle is not occasioned by the greater weight of the north extremity of the needle used, reverse its poles, as described under the last experiment, and then what was before the south pole will be depressed, the pole which was previously north being elevated.

98. The direction of the needle in respect to the earth is not fixed. Its *variation*, that is, its deviation from the true geographical meridian, is subject to several changes, more or less regular. So also is the intensity of the action exerted on it by the earth, as shown by the number of oscillations made by it in a given time. When examined also by means of apparatus constructed with great delicacy, the needle is found to be seldom at rest, but to be actuated with incessant fluctuations and tremulous motions, a phenomena supposed to comport more easily with the idea that electric currents constitute the influence by which it is controlled, than that its position is governed by the power of fixed permanent magnets in the earth.

99. The instrument represented in fig. 35 is intended to illustrate the magnetism of the earth on the latter supposition. (See section 96.) The compound bar

Fig. 35.

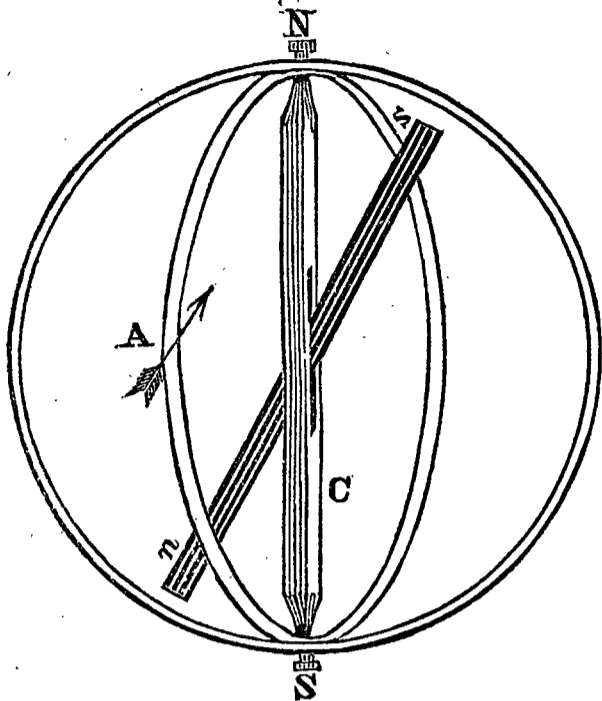

magnet, *n s*, is placed in the magnetic axis of the earth, not coinciding exactly with the axis of rotation, *N S*. A small magnetic needle placed at *B* on the magnetic meridian, will point both to the magnetic pole *s*, and to the north pole *N*, both being in the same line.

But if the needle be placed at *A*, or any where except on the magnetic meridian, it will point to the magnetic pole alone, the two poles not being in the same direction. The several magnets represented at *n s* are not fastened together, but only fixed on one axis. This allows their poles to be separated a little, to imitate more closely the distribution of terrestrial magnetism: the earth really having four magnetic poles, two strong and two weak; the strongest north pole is in America, the weakest in Asia. The line of no variation on the earth differs, however, considerably from the magnetic meridian, and the lines of equal variation and equal dip are not exactly meridians and parallels of latitude to the magnetic pole. The action of the magnetism of the earth at its surface is therefore irregular. The temporary fluctuations, however, are so slight as not to interfere with the use of the compass, and the variation of the needle is observed and noted on charts for different parts of the earth.

100. The variation of the needle at any place is found by observing the magnetic bearing of any heavenly body

whose true position at the time is known. It is immediately obtained by comparing the direction of the needle

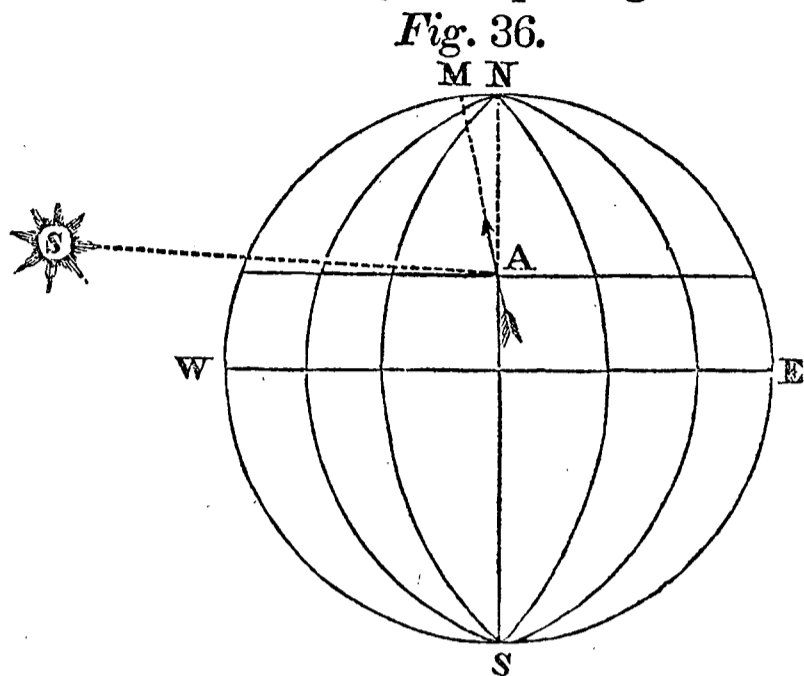

with the north star when it crosses the meridian or by calculation when the north star is at its greatest elongation. An observation of the sun, however, is usually preferred. The latitude of a

place *A* (fig. 36) being known, the exact bearing of the sun *S*, east or west, can be obtained by calculation,* for any given moment of time at that place. If the needle at *A* points to *M*, instead of *N*, the true north, the angle *M A S* will be the magnetic bearing of the sun west. Suppose this angle to be observed by the surveyor's compass, and found equal to 76° , the time being exactly noted. The angle *N A S*, the true bearing of the sun at the time, is then calculated. Suppose it equal to $85^\circ 30'$. The difference between the magnetic bearing and the true bearing, represented by the angle *M A N*, is the variation of the needle, and equals $9^\circ 30'$.†

101. Fig. 37 represents an instrument contrived to illustrate the theory which ascribes the magnetism of the earth to electrical currents circulating around it at right angles to its axis. *N S* is merely a wooden axis to the globe. When a galvanic current is sent through the

* See Bowditch's Navigator.

† The present variation at Boston is 9 deg. 30 min. west. The westerly variation appears to be increasing. The present dip is 74 deg. 20 min. north.

coil of wire about the equatorial regions, small needles placed in different situations will arrange themselves as

Fig. 37.

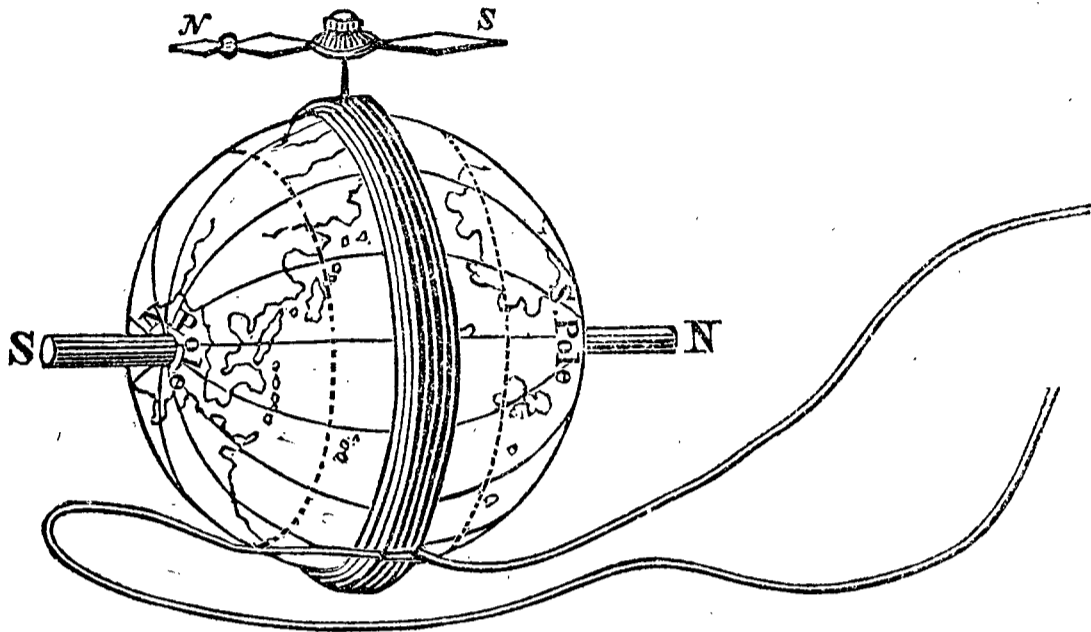

they would in similar terrestrial latitudes. By comparing this figure with fig. 35, representing the globe with the included magnet, a comparison may be made between the two theories of magnetism. The small needle arranges itself similarly on both globes. With a small dipping needle the resemblance between its positions on both, and those assumed by it on the earth's surface are very striking.

102. It will be observed that, in fig. 35, the *south* pole of the included magnet is represented at the *north* geographical pole of the earth. So also, in fig. 37, the wooden rod N S, passed through the axis of the globe, shows the direction of the polarity induced by the current to be contrary to that of the geographical poles. The reason of this may be easily understood. The northern magnetic pole is the one which *attracts* the north pole of a magnet, and therefore must itself possess south polarity and not north, as its name might seem to indicate. In the figure the battery current is of course

considered as flowing round the globe in the same direction as the supposed currents in the earth ; that is to say, from east to west, in the opposite direction to that of the earth's rotation. The principle on which the coil acts in inducing polarity will be explained in chap. II, sect. 2.

103. The aurora borealis is found to affect a delicately suspended magnetic needle, causing it to vibrate constantly but irregularly during its continuance, and especially when the auroral beams rise to the zenith ; if the aurora is near the horizon the disturbance of the needle is very slight. When the beams unite to form a corona, its centre is often in or near the magnetic meridian.

104. Within a few years a considerable number of magnetic observatories have been established in various parts of the world, for the purpose of making systematic and corresponding observations in relation to terrestrial magnetism. At these stations the variation of the needle and the intensity of the earth's action upon it are observed and recorded almost hourly, and on stated days at intervals of a few minutes only. These observations made by means of excellent instruments, and at the same time in widely remote regions, admit of comparison with each other, and can hardly fail to throw light on many parts of this important and intricate subject.

MAGNETISM.

II.

INDUCTION OF MAGNETISM.

I. BY THE INFLUENCE OF A MAGNET.

105. If a magnet is brought near to a piece of iron of any form, the latter becomes itself magnetic by the influence of the former.

EXP. 12.—Let M, fig. 39, be a bar magnet, the point of the arrow indicating the north pole and the feather the south pole; and B a bar of iron brought near to it. Now

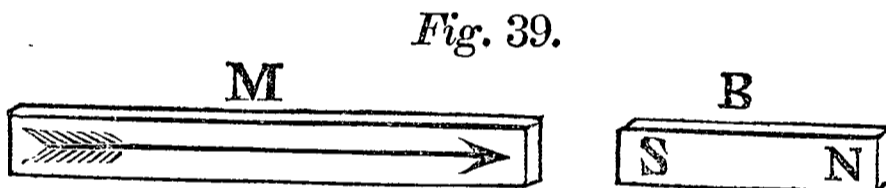

of iron brought near to it. Now by the influence of the magnet

the bar will become magnetized; the end towards the north pole will become south, and the end remote from it, north. The magnetical induction is stronger when the bar is brought in contact with the pole of the magnet; a decided effect, however, is produced by the mere proximity of the magnet to the iron. That the iron bar while under the influence of the magnet actually possesses magnetic properties, may be shown by presenting to it some iron filings or small nails, which will adhere to each extremity; and also by bringing near to it a small magnetic needle balanced on a pivot, the north pole of which will be repelled by the end of the bar farthest from the magnet M, and attracted by the end nearest to M. This induced magnetism will immediately disappear when the iron is removed from the vicinity of the magnet. If a small bar of steel, a large sewing-needle for instance, be substituted for the iron bar, it will acquire magnetism much less readily, but will retain it after removal; becoming in fact a permanent magnet.

106. It was for a long time supposed that the attractive force of the loadstone or any other magnet was exerted upon iron simply as iron; whereas it is now known to be the attraction of one pole of a magnet for the opposite pole of another magnet. In all cases, when a magnet is brought near to or in contact with any magnetizable bodies, as pieces of iron, iron filings, or ferruginous sand, all such bodies, whether large or small, coming thus within the influence of a magnetic pole, become magnetized; the part which is nearest acquiring a polarity opposite to that of the pole of the magnet; while the remote extremity becomes a pole of the same name.

EXP. 13.—If several pieces of iron wire of the same length be suspended from a magnetic pole, they will not hang parallel; but the lower ends will diverge from each other, in consequence of their all receiving the same polarity by induction, while the upper ends will be retained in their places by the attraction of the magnet.

EXP. 14.—Suspend two short pieces of iron wire by threads of equal length, fastened to one end of each piece so that the wires may hang in contact. If now the south pole of a magnet be placed below the wires, the lower ends of both will become north poles, and their upper ends south poles; and the wires will recede from each other. This divergence will increase as the magnet is brought nearer, until it reaches a certain limit, when its attraction for the lower poles will overpower their mutual repulsion and cause them to approach each other; while the repulsion of the upper ends will remain as before.

107. In former times artificial magnets were always made by induction from strong magnets previously prepared; the original source of the power being provided by natural magnets. When this was the case, it became

important to ascertain what arrangements and what modes of applying a magnet to a bar or needle, were most efficacious in communicating or developing the magnetic virtue; and accordingly various and complicated arrangements and manipulations for this purpose, are detailed in old treatises on this science. Recently, however, other and far more powerful means have been discovered for magnetizing bars of iron or steel, as will be hereafter described; so that all those methods have been in a great measure superseded. The induction of magnetism by the means above referred to, is now only employed for magnetizing needles or small bars.

108. It may however be convenient to know a good process for magnetizing (or *touching*, as it is technically called) by the aid of steel magnets. One of the simplest and best will here be given. A small bar of steel may be magnetized by drawing it across the poles of a magnet in the following manner; place the middle of the bar on one of the poles and draw one end of it over the pole a number of times; the direction of the motion being always from the middle to the end. Then turn the bar in the hand, and pass the other half over the other pole of the magnet in the same way. If the bar is thick, the process may be repeated with its different sides. The end which has been drawn over the south pole of the magnet will now possess north polarity, and the other extremity south polarity.

109. The magnet which is used to induce magnetism loses none of its own power in the process, but often receives a permanent increase by the reaction of the polarities it has induced upon its own.

EXP. 15.—That a magnet possesses greater power while exerting its inductive action, may be shown by suspending from one pole of a bar magnet as much iron as it can hold. If now a bar of iron be applied to the other pole, the first will be found capable of sustaining a greater weight than before.

110. When the arrangement of the experiment is such that while one extremity of an iron bar is exposed to the influence of one pole of a magnet the other extremity may be acted upon by the other pole, there will be a sort of double induction, and the effect will be increased.

EXP. 16.—Let M, fig. 40, be a compound horse-shoe magnet, and A an iron armature, of such a length that while one extremity

Fig. 40.

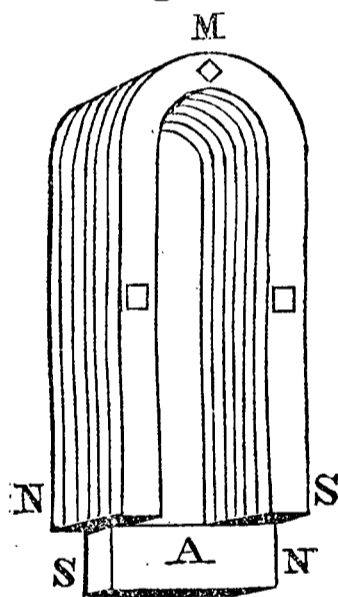

is applied to one pole of the magnet the other extremity may be applied to the other. In this case both poles of the magnet will act, each inducing a polarity opposite to its own in that extremity of the armature which is under its influence, as is indicated by the letters in the cut. The force with which the armature adheres will consequently be greatly increased, for there will be a strong attraction between each pole of the magnet and the corresponding extremity of the armature, that is, corresponding in position; for the polarity of the parts in

contact will evidently be of opposite denominations. If a bar of iron be placed between the north poles of two magnets, both extremities will become south poles, while a north pole will be developed at the middle of the bar.

111. Y ARMATURE. This consists of a piece of soft iron in the shape of the letter Y. If one of the branches of the fork be applied to the north pole of a horse-shoe magnet, as seen in fig. 41, the lower end of the armature, and also the other branch of the fork acquire north

Fig. 41.

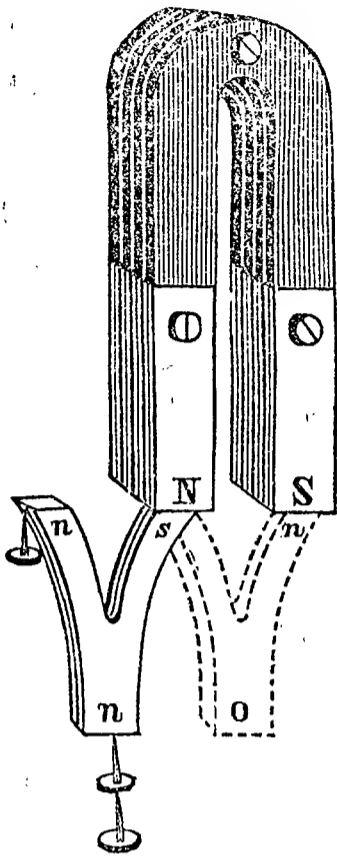

polarity, and will sustain small pieces of iron. If both branches of the fork be applied, one to each pole of the magnet, as shown by the dotted lines in the cut, the polarity of the lower end immediately disappears. This is because the two poles tend to induce opposite polarities of equal intensity in the extremity of the armature, which of course neutralize each other. If the branches of the fork are applied to the *similar* poles of two magnets, their influence will conspire in inducing the same polarity in the lower end, and a greater weight will be supported by it, than when one branch is applied to a single pole.

Fig. 42.

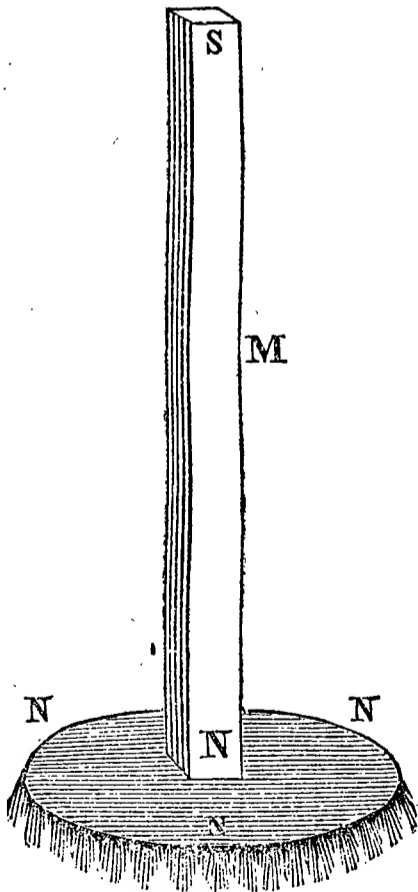
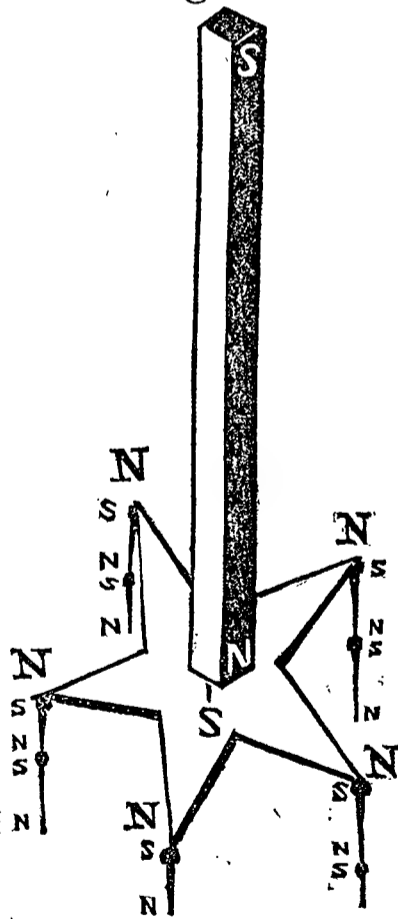

Fig. 43.



Exp. 17.—Place the north pole of a bar magnet M (fig. 42) on the centre of a circular plate of iron; it will now induce south polarity in the part immediately beneath it, and a weak north polarity in the whole circumference, so that it will sustain iron filings as shown in the cut.

Exp. 18.—If an iron plate be cut into the form of a star, as in fig. 43, each point will acquire a stronger north polarity than the edge of the round plate

acquire a stronger north polarity than the edge of the round plate

Fig. 44.

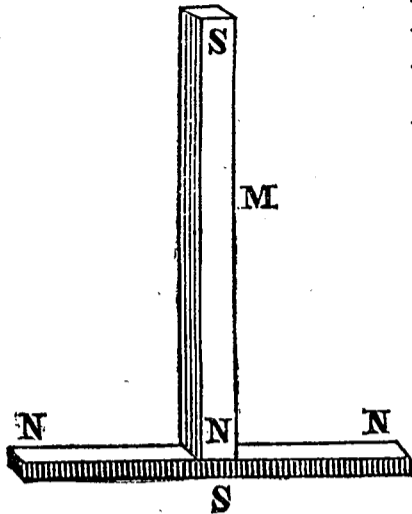

in the last experiment, and may be able to lift several iron screws or nails; the letters in the cut indicate the position of the poles.

EXP. 19.—Place the north pole on the middle of a bar of iron; both extremities of the bar will become north poles and the middle a south pole, as indicated by the letters in the cut (fig. 44) where M represents the magnet.

112 Fig. 45 represents the successive development of magnetism in several bars of iron. The bar *a* being

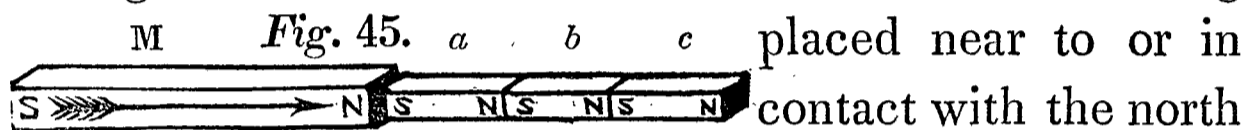

placed near to or in contact with the north pole of a magnet M, becomes itself temporarily magnetic, and is able to induce magnetism in a second bar *b*; this again in *c*, and so on, each succeeding bar being less and less strongly magnetized. The same thing occurs with the iron nails represented in fig. 43, hanging from the points of the star. If the magnet M be removed from the bar *a*, the magnetism of the whole series disappears. This successive development of magnetism is well shown by plunging one of the poles of a strong bar magnet in a mass of small iron bodies, such as screws, nails, &c.

113. It is not easy to magnetize a bar whose length considerably exceeds its diameter, in such a manner that its two poles may be developed along two opposite sides instead of at its extremities; for the opposite polarities tend to keep as far from each other as possible. The points of greatest intensity in a permanent magnet are not however situated precisely at its ends, but at a little distance from them.

114. The inductive action of a magnet is not impeded by the interposition of any unmagnetizable body whatever. Thus, if a plate of glass be placed between the magnet and a piece of iron, the iron will be as much influenced, and will be attracted as strongly, as it would be at the same distance with no glass interposed.

115. FRACTURE OF MAGNETS. A close analogy exists between the phenomena of magnetism and electricity in many important points. But in some respects it altogether fails. Electricity, whether positive or negative, can be actually transferred from one body to another, so that a body may be charged with an excess of electricity of either kind. It is not so with magnetism. Every magnet possesses both polarities to an equal extent, though each may be diffused through different portions of its mass. A long conductor exposed to the inductive influence of an electrified body, has opposite electricities developed at its two ends. If now it be divided in the middle, we obtain the two electricities separate; one half of the conductor possessing an excess of positive, the other of negative electricity. The condition of a magnet in regard to the distribution of its polarities appears to be exactly analogous to that of the conductor; the north polarity seeming to be collected in one half of its length, and the south in the other. We might therefore naturally expect that by breaking the magnet in halves we should obtain the two polarities separate, one in each portion of the bar. But such is not the case; each half at once becomes a perfect magnet. The original north pole still remains north, but the other extremity of the magnet, that is, the broken

end, has acquired a south pole. The converse of this occurs with respect to the other portion in which the south pole was situated, as shown in fig. 46. These halves may be again broken with the same result; and

Fig. 46.



in fact into however small fragments a magnet may be subdivided, each will possess a north and a south pole.

EXP. 20.—Suspend a piece of iron from one pole of a magnet, and bring up to this pole the opposite pole of another magnet. The iron will immediately fall: the poles when in contact representing the middle or neutral portion of a magnet. If the piece of iron is nearly as heavy as the pole can sustain, it will fall on the mere approach of the other magnet to the pole and before it touches it.

II. BY THE INFLUENCE OF A CURRENT OF ELECTRICITY.

116. It has already been stated, under the head of the directive tendency of a magnet in reference to a current of electricity, that a magnetized body, freely suspended within the influence of such a current, tends to assume a position at right angles to it. It is also found that if any magnetizable body be placed in this position with regard to an electrical current, it acquires magnetism by its influence. This phenomenon is termed *electro-magnetic induction*. The subject of this section, with the one referred to above, form the department of *electro-magnetism*.

117. A short copper wire connecting the poles of a battery will attract iron filings, as represented in fig. 47.

It will be observed that the lines of filings have not that bristled, divergent arrangement, which they exhibit under the influence of a steel magnet, but adhere equally

Fig. 47.

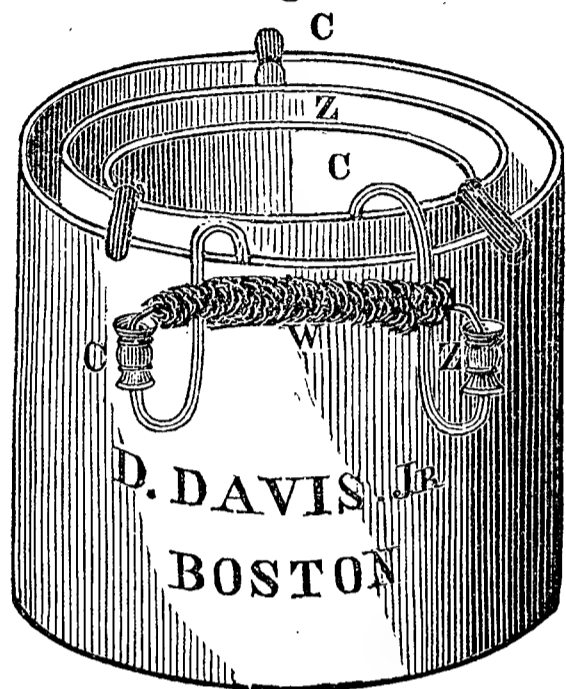

all around the circumference of the wire; forming circular bands, the particles of which mutually cohere in consequence of each particle becoming a magnet with its poles transverse to the wire. The attraction is also equal at every part of the length of the wire: hence these transverse bands, lying in contact

with each other, present the appearance of a closely-compacted layer. Whatever form the metal conducting the electricity may have, the filings will always arrange themselves in lines encircling it at right angles to the course of the current. The iron filings will of course fall off when the current ceases to flow; but if steel filings be employed, they will remain attached, in consequence of the adhesion of the magnetized particles among themselves.

EXP. 21.—A sewing-needle may be magnetized by placing it across the wire and at right angles to it. If placed parallel to the wire, it acquires feeble polarity on its opposite sides instead of in the direction of its length, and probably will not retain it after removal: it being very difficult to maintain this transverse distribution of magnetism in magnets whose length considerably exceeds their diameter.

EXP. 22.—Place a short iron rod or a piece of iron wire at right angles to the wire conveying the current. On bringing a delicate

magnetic needle near to its extremities, they will be found to possess a sensible polarity; which however they will lose when removed from the influence of the current.

118. Though the relation between the current and the direction of the polarity which it induces is fixed and determinate, yet it is very difficult to express. The action of the current in inducing magnetism follows the same law which we have already seen to determine its influence in moving a magnetic pole placed near it. See § 79.

119. The following mode of fixing the rule in the memory is perhaps the best that has been contrived. First, it is more natural to fix our attention on the current of *positive*, than of negative electricity. Secondly, in a vertical wire, a *descending* current will occur to us more readily than an ascending one; or, if we imagine ourselves borne along by the current, it would be more natural to conceive ourselves moving with our *feet* foremost; but if, on the contrary, we suppose ourselves to be at rest, we should conceive the current to be passing from our head to our feet. Our *face* would, of course, be turned *towards* the body to be magnetized; we should attend to the *north* pole in preference to the south; and to our *right* hand rather than to our left. Combining these conditions, then, we may always recollect, that *if we conceive ourselves lying in the direction of the current, the stream of positive electricity flowing through our head towards our feet, with the bar to be magnetized before us, the north pole of that bar will always be towards our right hand.* If any one of these conditions be reversed, the result is reversed likewise.

Fig. 48.

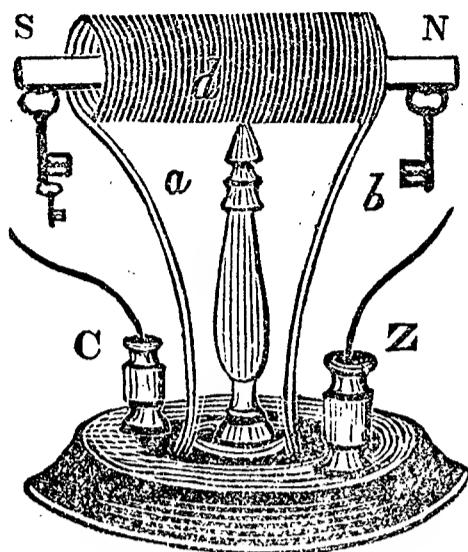

120. **HELIX, ON STAND.** The magnetizing power will be greatly increased if the wire be coiled in the manner of a cork-screw, so as to form a hollow cylinder into which the body to be magnetized can be inserted. Such a coil is denominated a *Helix*; and is represented at *d*, fig. 48, mounted upon a stand.

121. In using the coil, the following rule will indicate the extremity at which the north pole will be found. If the helix be placed before the observer with one of its ends towards him, and the current of electricity in passing from the positive to the negative pole of the battery, circulates in the coil in a direction similar to that of the hands of a watch or the threads of a common screw; then the north pole will be *from* the observer, and the south pole *towards* him. If it passes round in the contrary direction, the poles will be reversed. Or the formula may be stated thus: the *south* pole will always be found at that end of the helix where the positive current circulates in the direction of the hands of a watch.

122. Thus, in fig. 48 the current flows from the cup C, up the wire *a*, to the coil; and then down again by the wire *b*, to the cup Z, producing north polarity at N, and south polarity at S. This rule is strictly deducible from that given in § 119 for finding the direction of the polarity induced by a current flowing in a straight wire.

EXP. 23.—Place a bar of soft iron within the coil, and connect it with the battery by means of the two cups attached to the stand. Then the two extremities of the bar will be found to be strongly magnetic, as will be seen by bringing a key or other piece of iron in contact with them. On separating one of the wires communicating with the battery, the magnetic power of the iron bar will be immediately destroyed, and the key will drop. If iron filings or small nails are held near one of the extremities of the iron, they will be taken up and dropped alternately, as the connection with the battery is made or broken.

EXP. 24.—If two soft iron bars are inserted in the helix, at the opposite ends, in such a manner as to have their extremities in contact in the middle of the helix, they will be held in conjunction by a strong force.

EXP. 25.—The coil being connected with the battery and a bar of iron placed within it, bring a magnetic needle near the two extremities of the bar, in succession. One of the extremities will be found to have north and the other south polarity, and they will attract and repel the poles of the needle accordingly.

EXP. 26.—Place a steel bar, instead of an iron one, within the helix. It will acquire polarity somewhat less readily, but the polarity will continue after the connection with the battery is broken, and after it is removed from the helix; and thus a permanent magnet be made. Any small rods or bars of steel, needles, &c., will answer for this experiment.

EXP. 27.—Bars of iron or steel brought near the outside of the helix will not acquire any appreciable degree of magnetism. An iron tube will not become perceptibly magnetic when a current is passed through a helix placed within it, though when enclosed in a larger helix it will become strongly so.

EXP. 28.—If a needle or a small bar of steel previously magnetized, is placed within the helix, in such a position as to bring the north pole at the south pole of the helix, as indicated by the preceding rule, the polarity of the needle or bar will be destroyed, and perhaps a new and contrary polarity communicated.

EXP. 29.—If a small magnetic needle be suspended by a thread near the helix, the mutual action between them will cause the

needle to enter the helix, its north pole entering the south end of the helix, or its south pole the north end. When the needle reaches the middle, its north pole will be within that end of the coil which exhibits north polarity. If the magnet be placed within the helix, in a contrary direction, its north pole entering the north end, it will be repelled, and then revolving without the helix, will return and enter by the other pole. This effect will take place unless the electro-magnetic power of the coil is sufficient to reverse the poles. When the needle has entered with its poles corresponding in direction with those of the helix, the action of the helix will tend to keep it in the middle of its length, though not in the line of its axis.

Exp. 30.—Place the helix with its axis vertical, and a small rod of iron or steel within it. If it be now connected with the battery, it may be raised from the table without the bar falling out: the tendency of the helix to keep the bar within it overpowering its gravitation.

Exp. 31.—The power of the helix to induce magnetism may be shown by holding it vertically, as in the last experiment, while the current is flowing. A small steel bar, merely allowed to fall through the helix, will acquire a considerable degree of magnetism.

123. FLAT SPIRAL. Fig. 49 represents a ribbon of sheet copper, coiled into a spiral. This instrument is described here in consequence of its possessing considerable magnetizing power, though its principal uses will not

Fig. 49.

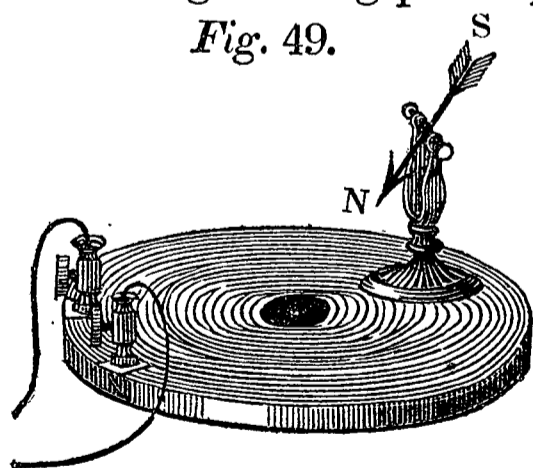

be mentioned till the inductive action of electrical currents comes under consideration, in chap. III, section 1. The copper ribbon may be an inch wide and one hundred feet long, the strips being cut from a sheet, and soldered together. Being then wound with strips of thin cotton, it is coiled upon itself, like the mainspring of

a watch; instead of covering it with cotton, it may be coiled with a strip either of cotton or list intervening. Two binding screw cups are soldered to the ends of the ribbon; the internal end, for convenience, is brought from the centre, underneath the spiral, to its outside, care being taken to insure insulation where it passes the coils. The whole may be firmly cemented together, if desired, by a solution of shellac in alcohol. The spiral being connected with the battery, its two faces will exhibit strong polarity: a dipping needle placed on any part of its surface or near it will always direct one of its poles towards the centre, as seen in fig. 49, where a dipping needle *NS* is represented on the spiral. On reversing the battery current, the other pole of the needle will turn towards the centre. If the spiral be fixed in a vertical position, a horizontal magnetic needle may be used with the same result. When brought near to one side of the coil, it will be found to direct its north pole constantly towards the centre; when on the other side, its south pole. When either the horizontal or dipping needle is placed near the outside, with its axis of motion in the same plane as the spiral, neither pole will be directed towards the centre, but the magnet will place itself at right angles to the plane of the spiral.

EXP. 32.—The magnetizing power of the spiral may be shown by connecting it with the battery, and placing a rod of iron or steel in the central opening, or upon it in the direction of a radius, when the iron will become temporarily magnetic, and the steel permanently so. If the bar, when laid upon the coil, extends across the central opening, both ends will become similar poles, and the part over the centre, a pole of the opposite denomination.

124. If the spiral be of considerable diameter, it will exert a feeble magnetizing power on its outside, and a

short rod of soft iron placed near it will become able to sustain a few iron filings; its polarity will be in the reverse direction to that which it would acquire were it placed within. The influence of the earth in inducing magnetism in the iron must not be overlooked; it may be allowed for by observing whether the transmission of the current through the coil causes more or fewer filings to be sustained by the bar, or avoided by placing the spiral in a vertical position with its axis east and west, and the rod horizontally east and west.

125. When the spiral is in the form of a ring, having a large central opening, it will be found that the magnetism communicated to a bar placed in the centre will be somewhat less than when it is near the side, though very much greater than that acquired by one on the outside.

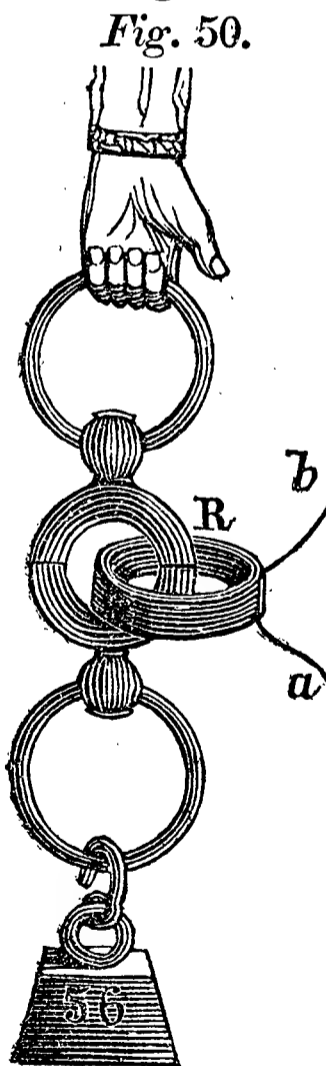

126. **MAGIC CIRCLE.** This is a helical coil of wire, shown at R in fig. 50, about two inches in diameter, with the extremities *a* and *b* of the wire left free, in order to be inserted into the cups of the battery. If two semicircular armatures of three quarter inch iron, provided with handles, are passed partly within the ring, as represented in the cut, they will adhere together so strongly as to support a weight of fifty-six pounds or more, when the current from even a small battery is transmitted through the coil. The attractive power manifested by the armatures when near each other, but not in actual contact, is comparatively very feeble.

127. If a ring and armatures of larger size are employed, as represented in fig. 51, where A A are the armatures, and C the coil, great force will be required

Fig. 51.

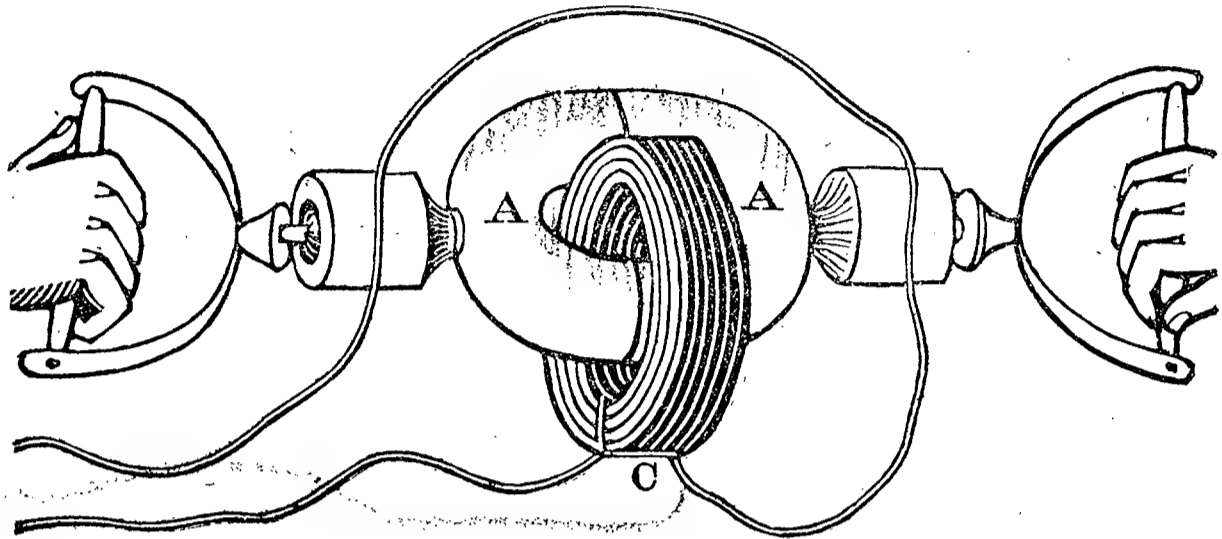

to separate them. The handles are attached to the armatures by ball and socket joints, to prevent them from being twisted or wrenched by irregular pulling. The induction of magnetism in these armatures by means of the current from a thermo-electric battery has already been mentioned in § 56.

128. If the coil while conveying the current be plunged in a mass of small iron nails, a large quantity of them will be sustained by it. An iron bar introduced within it will become strongly magnetic. If the flow of the current in the coil is stopped while the armatures are applied to each other, as shown in figures 50 and 51, they will still continue firmly attached; but if once separated, will not adhere again.

129. **PAGE'S DOUBLE HELIX.** This instrument consists of two helices fixed side by side, into which two bars of iron of the U form, fitted with handles, can be inserted so as to bring their extremities in contact in the centre. A very strong force will be required to separate

them, when the electrical circuit is completed through the helices. The attractive force manifested by the bars when their extremities meet in the centres of the helices is much greater than when the ends of one of the bars project beyond the coils. It is also greater with short bars than with long ones.

130. DE LA RIVE'S RING. A coil of wire while transmitting the electric current is not only capable

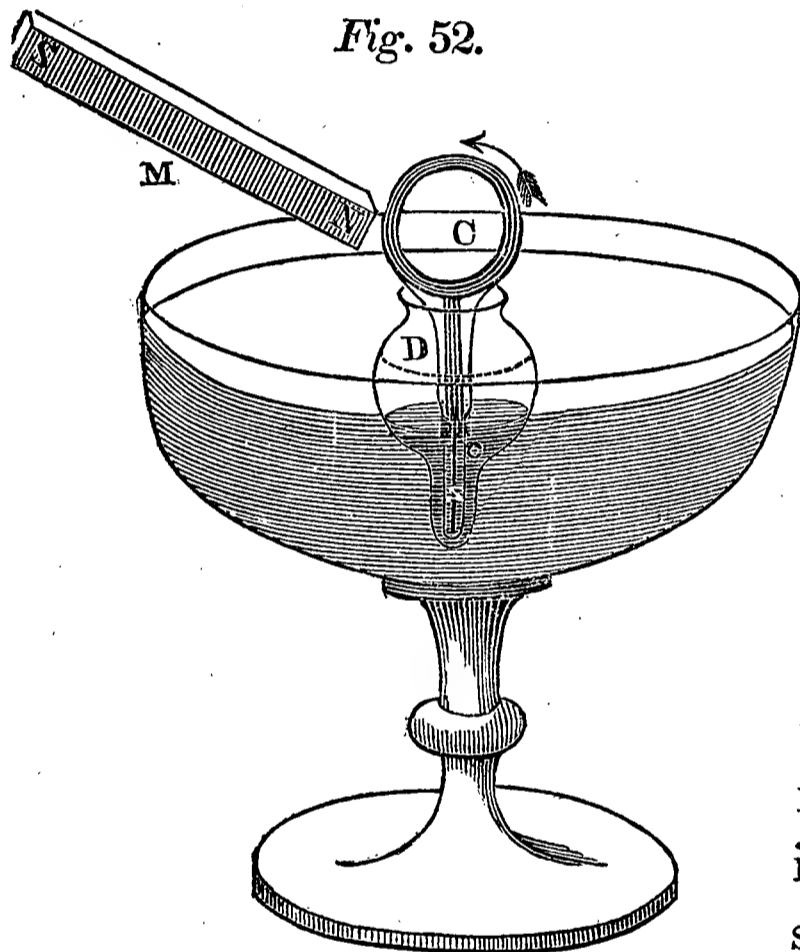

of communicating magnetism to iron or steel placed within it, but itself possesses magnetic polarity. This fact may be shown by means of the apparatus figured in the adjoining cut. One end of the wire forming the coil C is soldered to a very small plate of cop-

per c, and the other to a similar plate of zinc z. These plates are fastened to a small piece of wood, in order to keep them apart, and placed in a little glass cup D. To put the instrument in action, a sufficient quantity of water, acidulated by a few drops of sulphuric or nitric acid, is poured into the glass cup to cover the plates, and the whole apparatus is floated in a basin of water. The coil will now be found to place itself with its axis north and south; its polarity being in the same direction

as that which would be exhibited by an iron rod placed within it. The arrow indicates the course of the galvanic current in the coil, from the copper to the zinc.

EXP. 33.—Take a bar magnet *M*, and holding it horizontally, bring its north pole near to the south pole of the ring. The ring will move towards the magnet, and pass over it until it reaches its middle, where it will rest in a state of equilibrium; returning to this position, if moved towards either pole and then left at liberty. Now, holding the ring in its position, withdraw the magnet, and pass it again half way through the coil, but with its poles reversed. The ring when set at liberty, will, unless placed exactly at the centre, move towards the pole which is nearest; and passing on till clear of the magnet, will turn round and present its other face. It will then be attracted, and pass again over the pole till it rests in equilibrium at the middle of the magnet.

131. ELECTRO-MAGNETS. Bars of iron wound with insulated wire so as to be enclosed in a permanent helix, are termed *Electro-Magnets*. During the passage of an electric current along the wire, they exhibit a remarkable degree of magnetic power, indeed far superior to that of steel magnets of the same size. They are usually

Fig. 53.

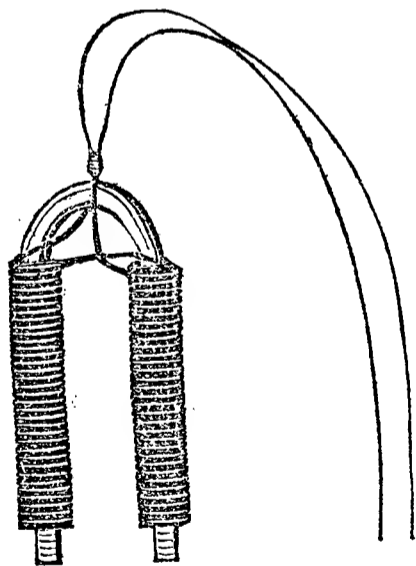

made in the U form, as shown in fig. 53, the bar being from six to eighteen inches in length before being bent. These, when connected with a medium size cylindrical battery, will sustain from a few pounds to fifty or a hundred pounds. A current from the thermo-electric battery (fig. 15), when transmitted through the wires of an electro-magnet, induces a considerable charge of magnetism.

132. Prof. Henry, late of the Albany Academy, ap-

pears to have been the first to construct electro-magnets of any great lifting power. In one instance, he employed a soft iron bar, two inches square and twenty inches long, bent into the horse-shoe form; its weight was twenty-one pounds. This was wound with five hundred and forty feet of copper bell-wire, not in one continuous length, but in nine separate coils of sixty feet each, each strand of wire occupying about two inches of the bar, and being coiled several times backward and forward upon itself. By this arrangement the different coils could be combined in a number of ways; thus, if the second end of the first wire was soldered to the first end of the second, and so on through the series, the whole would form a single coil of five hundred and forty feet. Or they might be united so as to form a double coil of two hundred and seventy feet, or a triple one of one hundred and eighty feet, and so on. A small battery was used, consisting of two concentric cylinders of copper, with a zinc cylinder between them. The battery required only half a pint of diluted acid for its charge, and the surface of zinc exposed to the acid was but two-fifths of a square foot. Each strand of the wire being soldered in succession to this battery, one at a time, the magnetism was just sufficient to sustain the armature, which weighed seven pounds. When the first end of each of the nine strands was soldered to the zinc cylinder and the second end to the copper cylinder, so that the current circulated in nine channels of sixty feet each, the magnet supported the extraordinary weight of six hundred and fifty pounds. With a larger battery it sustained seven hundred and fifty pounds. Each pole, separately, could lift but five

or six pounds. On uniting the ends of the wires, so as to form a continuous length of five hundred and forty feet, the weight raised was only one hundred and forty-five pounds. He afterwards constructed another electro-magnet on a similar plan, which was wound with twenty-six strands of copper wire, covered with cotton thread, the aggregate length of the wires being seven hundred and twenty-eight feet. With a battery of 47.9 square feet, this magnet supported two thousand and sixty-three pounds, or nearly a ton. Others have since been made with a lifting power of three thousand pounds.

Fig. 54.

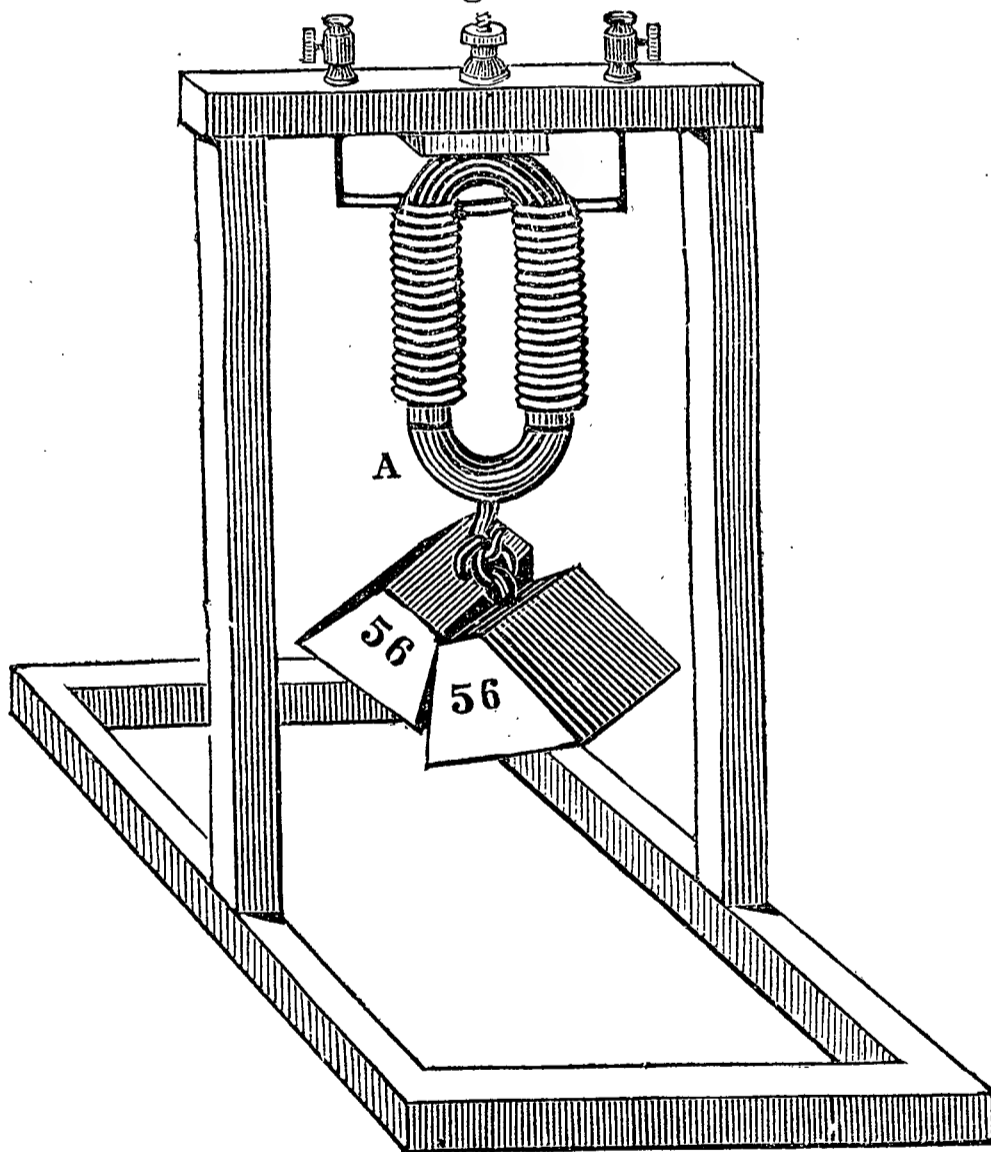

133. Fig. 54 represents an electro-magnet fixed in a frame, for the purpose of supporting heavy weights. A

semicircular armature A is adapted to its poles, as this form gives the greatest lifting power. It will be observed that if the iron of the magnet is soft and pure, its magnetic power will be immediately communicated and lost, according as the connection with the battery is made or broken. If, however, the armature is applied to the poles, and the flow of the current is stopped while it is attached, it will continue to adhere for weeks or months with great force, so as to be able to sustain one third or one half as much weight as while the current was circulating. But if the keeper be once removed, nearly the whole magnetism will disappear, and the magnet, if of good iron, will not even be able to lift an ounce. The polarity of the magnet will of course be reversed by changing the direction of the current.

EXP. 34.—A small electro-magnet will sustain a large mass of iron nails or filings about its poles, which will fall when the flow of the current is stopped. A very small electro-magnet has been made to lift four hundred and twenty times its own weight.

134. An electro-magnet, like the steel magnet, exerts its attractive force through intervening substances; and the phenomena are more striking with the former, in consequence of its greater power. Thus, it will often be able to lift its armature, with a plate of glass interposed; and when a few thicknesses of paper only intervene, a considerable additional weight will be supported.

135. ELECTRO-MAGNET, WITH THREE POLES. This consists of an iron rod wound with wire, which is carried in one direction around half the length of the rod, and then turns and is wound in the other direction. The effect of this arrangement is, that when the connection

is made with the battery by means of the brass cups on the stand, the two extremities of the bar, *c* and *d*, fig. 55, become similar poles, while the middle *a* acquires a

Fig. 55.

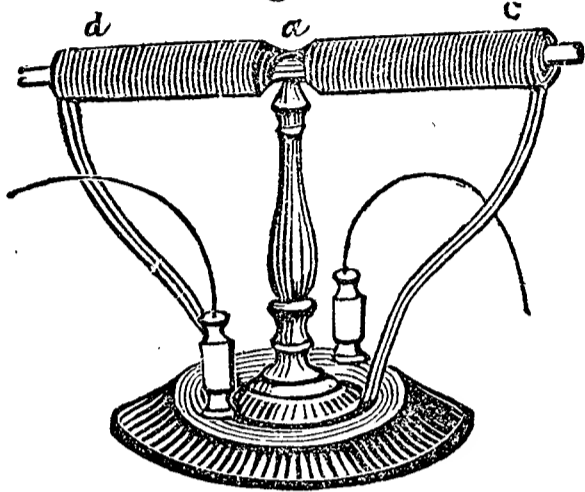

polarity opposite to that of the ends. By reversing the direction of the current, all the poles will be reversed. The arrangement of the poles may be shown by passing a magnetic needle along the bar, or by small iron tacks, a large number of which will adhere to its extremities and to its middle.

136. COMMUNICATION OF MAGNETISM TO STEEL BY THE ELECTRO-MAGNET. The great power possessed by the electro-magnet, renders it peculiarly fitted for inducing magnetism in steel; hence it is very convenient for charging permanent magnets. A short steel bar, if applied like an armature to the poles of a U shaped electro-magnet, will become strongly magnetic, the end which was in contact with the north pole acquiring, of course, south polarity. A longer bar may be charged, by employing the same process that has been described in § 108, for *touching* by steel magnets.

137. Bars of the U form are most readily magnetized by drawing them from the bend to the extremities across the poles of the U electro-magnet, in such a way that both halves of the bar may pass at the same time over the poles to which they are applied. This should be repeated several times, recollecting always to draw the bar in the same direction. Then, if it has a considerable

thickness, turn it in the hand and repeat the process

Fig. 56.

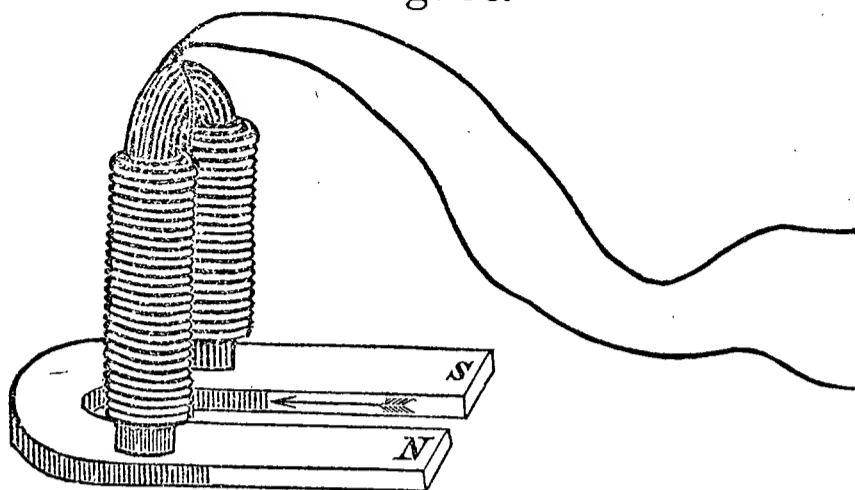

with its opposite surface, keeping each half applied to the same pole as before. Of course, the result will be the same, if the steel bar is

kept stationary and the poles of the electro-magnet passed over it in the proper direction, that is, in the reverse direction of the arrow in fig. 56.

138. In order to remove the magnetism of a steel magnet of the U form, it is only necessary to reverse the process just described; that is, placing one pole of the electro-magnet on each of its poles, to draw the electro-magnet over it, towards its bend, in the direction of the arrow in fig. 56. In this way, a steel magnet may often be so completely discharged as to be unable to lift more than a few iron filings. A bar magnet may also be deprived of its magnetism in a great degree by passing the north pole of an electro-magnet over it, from its south pole to its middle, and then lifting it off perpendicularly; if, then, the south pole be passed in the same manner over the other extremity of the steel bar, it will be found to have lost the greater part of its polarity. If necessary, this process may be repeated several times. A still more effectual mode is to make use of two electro-magnets; place the north pole of one on one end of the bar, and the south pole of the other on its other extremity, and draw the poles along the bar till

they meet at its middle; then lift them off. If the steel bar whose polarity is to be removed is of small size, steel magnets may be substituted for the electro-magnets in the above processes, though with less effect.

MOTIONS PRODUCED BY THE MUTUAL ACTION OF MAGNETS
AND CONDUCTORS.

139. When a wire conveying a current of electricity is brought near to a magnetic pole, the pole tends to revolve around it, as has been explained in § 79. If the current acts equally upon both poles, no rotation occurs, because they tend to move in opposite directions; and the magnet rests across the wire in a position of equilibrium between the two forces. But if the action of the current is limited to one pole (which was first effected by Prof. Faraday), a continued revolution is produced. If the magnet has liberty of motion, it will revolve around the wire; if the wire only is free to move, it will rotate around the pole. When both the wire and the magnet are at liberty to move, they will revolve in the same direction round a common centre of motion. A number of instruments have been contrived for exhibiting these movements.

140. **MAGNET REVOLVING ROUND A CONDUCTING WIRE.** In the instrument represented in fig. 57, the magnet N S has a double bend in the middle, so that this part is horizontal, while the extremities are vertical. At its north pole N is attached a piece of brass at a right angle, and bears a pivot which rests in an agate cup fixed on the stand. A wire loop attached to the upper pole S encircles a vertical wire fixed in the axis of motion, and

thus keeps the magnet upright. The galvanic current is conveyed by this vertical wire: it is surmounted by a brass cup A, and its lower end dips into a small mercury cup on the horizontal portion of the magnet.

Fig. 57.

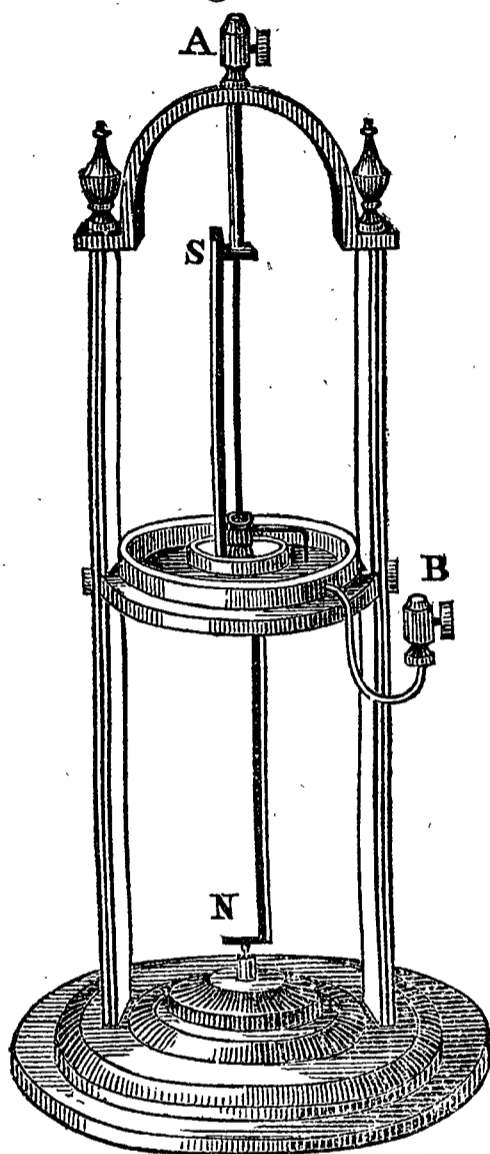

on the horizontal portion of the magnet. From this part projects a bent wire, which dips into a circular cistern of mercury, open in the centre, to allow the magnet to pass through, and supported independently of it. A wire, terminated by a brass cup B, for connection with the battery, proceeds outwardly from the cistern. This arrangement allows the current to flow down by the side of the upper pole of the magnet, until it reaches its middle, whence it is conveyed off in such a direction as not to act upon the lower pole. On making connection with the battery, the

magnet will revolve rapidly around the wire; the direction of the rotation depending upon that of the current.

141. **MAGNET REVOLVING ROUND ITS OWN AXIS.** The instrument represented in fig. 58 is designed to show that the action between the current and the magnet takes place equally well when the magnet itself forms the conductor of the electricity. The lower end N of the magnet, being pointed, is supported on an agate at the bottom of a brass cup connected under the base-board with the binding screw cup P. The upper end

S is hollowed out to receive the end of the wire fixed to the cup A; the brass arm supporting this cup is insulated from the brass pillar at I I, by some non-conductor of electricity.

Fig. 58.

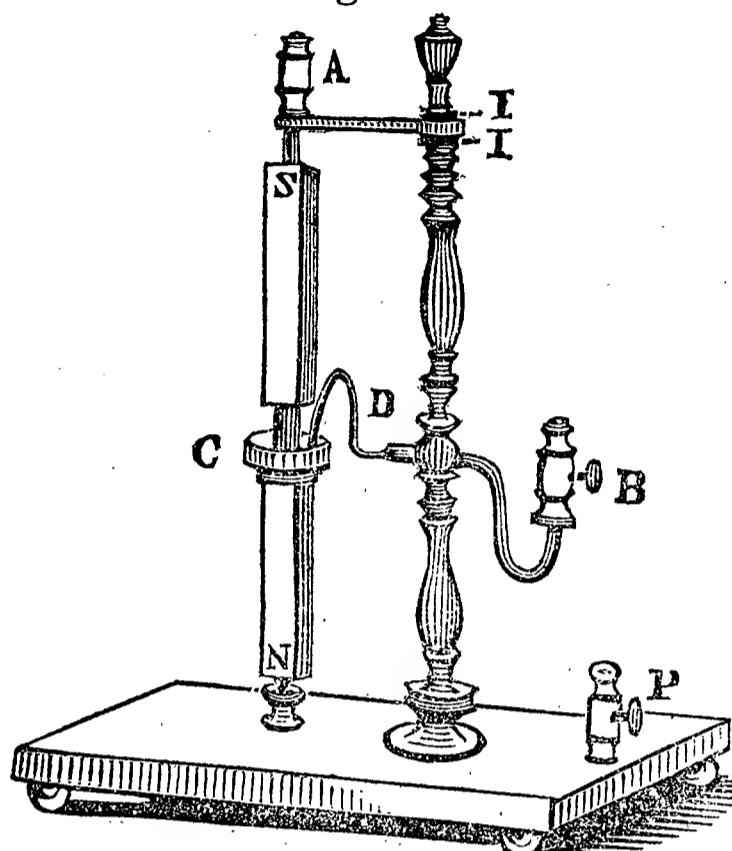

lated from the brass pillar at I I, by some non-conductor of electricity. To the middle of the magnet is fixed a small ivory cistern C, for containing mercury, into which dips the end of the wire D. Thus the magnet is supported with its north pole downwards, and is free to

rotate round its vertical axis. A little mercury should be put into the cavity at S, and into the brass cup at N, and the ivory cistern be filled sufficiently to establish a connection between the magnet and the wire D.

142. On connecting the cups A and B with the battery, the current will flow through the upper half of the magnet, causing it to rotate rapidly. If the cups B and P form the connection, the current will traverse the lower half, equally producing revolution of the magnet. Now connect A and P with the battery, and no motion will result, because the electricity passes through the whole length of the magnet in such a manner that the tendency of one pole to rotate is counteracted by that of the other to move in the opposite direction. Connect B with one pole of the battery, and A and P both with the other pole. The magnet will now revolve; since the

current will ascend in one half of its length and descend in the other.

143. **REVOLVING WIRE FRAME.** The revolution of a conductor round a magnet is shown by the instrument represented in fig. 59. Two light frames of copper wire *R R* are supported by pivots resting on the poles *N* and *S* of a steel magnet of the U form; a small cavity being drilled in each pole to receive an agate for the bearing of the pivot.

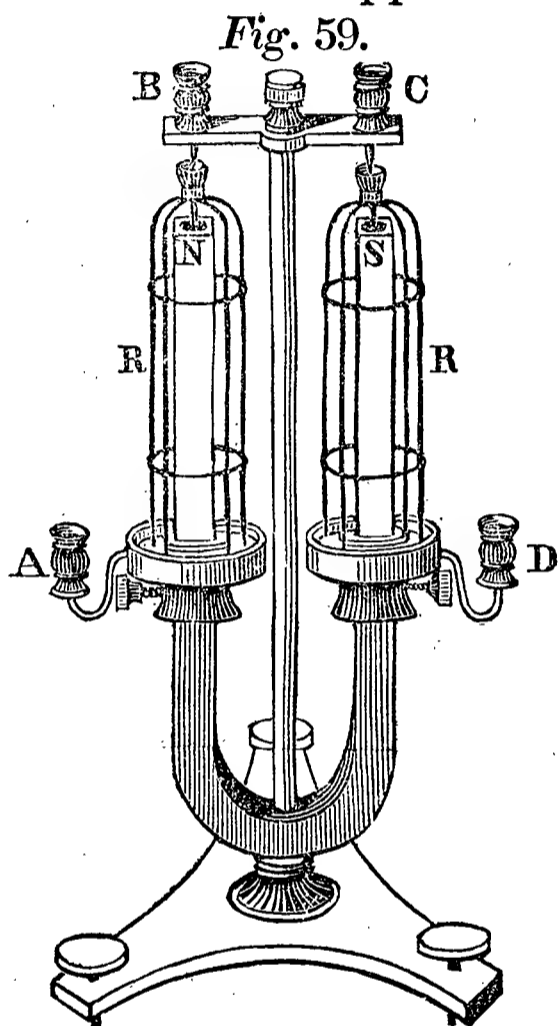

Fig. 59.

U form; a small cavity being drilled in each pole to receive an agate for the bearing of the pivot. The lower extremities of the wires dip into mercury contained in two circular cisterns sliding on the arms of the magnet. Bent wires passing from the interior of the cells support the cups *A* and *D*; and the cisterns themselves are fixed at any required height by means of binding screws attached to them. Each of the wire frames

is surmounted by a mercury cup; into these dip the wires projecting downwards from the cups *B* and *C*.

144. The cisterns being partly filled with mercury, fix them at such a height that the lower extremities of the wire frames may just touch its surface. The cups surmounting the frames should also contain a little mercury. On connecting the cups *A* and *B* with the battery, the left hand frame will revolve, in consequence of the action of the north pole of the magnet upon the current flowing in the vertical portions of the frame. By uniting *C* and

D with the battery, the other frame will rotate. On transmitting the current from A to D, it will ascend in one frame, and passing along the brass arm which supports B and C, will descend in the other, causing them both to revolve in the same direction. Instead of the frame, a single wire may be employed, having the form of a loose helix surrounding the pole, its convolutions being a quarter of an inch or more apart.

Fig. 60.

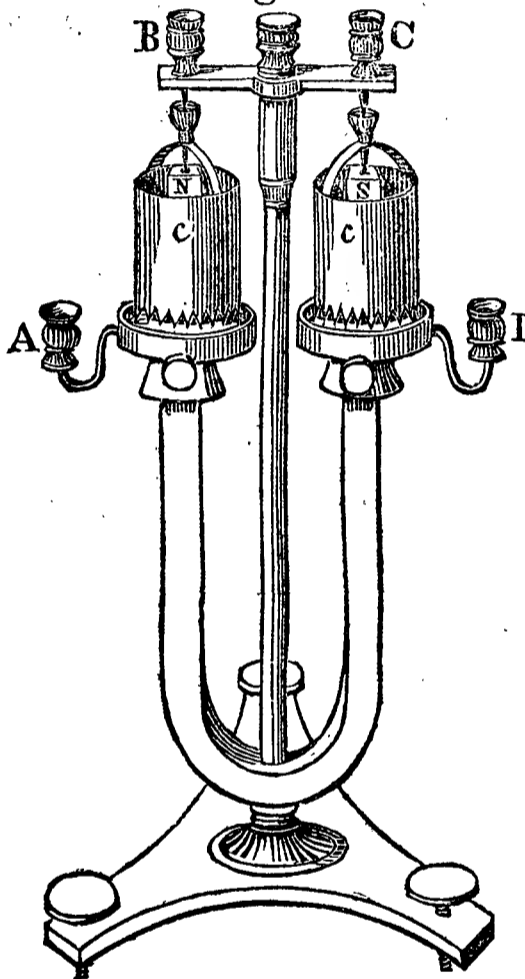

145. REVOLVING CYLINDER. This instrument is on the same principle as that last described, and the motion takes place in the same manner: the only difference being that two light copper cylinders *c c*, fig. 60, are substituted for the wire frames. These cylinders are serrated at their lower edge, as shown in the figure, to lessen the friction which they experience in moving through the mercury. The cups for battery connections are lettered in correspondence with

those in the preceding cut, fig. 59.

146. In the case of a conducting wire revolving round a magnet, the circumstance of the two being joined together does not affect the result, the wire moving with sufficient power to cause the magnet to turn on its axis with considerable rapidity, when delicately supported: a bar magnet is of course employed. A figure and description of an instrument designed to show this revo-

lution will be found in Silliman's American Journal of Science and Arts, Vol. XL, No. 1, p. 111.

147. The current passing within the voltaic battery itself exhibits the same electro-magnetic properties that it does while flowing along a conducting wire connecting the poles. Hence the battery, if made small and light, will revolve by the influence of a magnet. This is effected in the following manner.

148. AMPERE'S ROTATING BATTERY. A small double cylinder of copper, closed at the bottom, is supported upon the pole of a magnet, by means of an arch of copper passing across the inner

Fig 61.

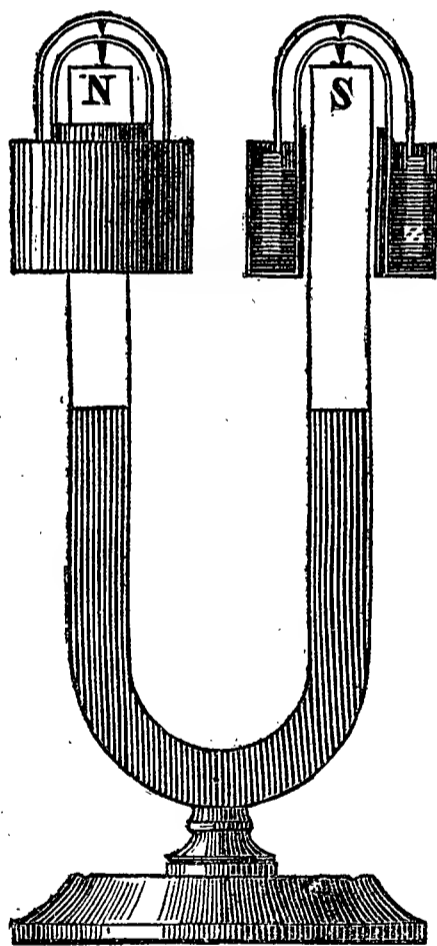

of copper passing across the inner cylinder, and having a pivot projecting downwards from its under surface, which rests in an agate cup on the pole. The inner cylinder of course has no bottom. A cylinder of zinc is supported by a pivot in a similar manner upon the copper arch, and being intermediate in size between the two copper cylinders, hangs freely in the cell. This arrangement allows each plate to revolve independently of the other. In fig. 61 two batteries are represented, one on each pole of a U magnet, the one on the south pole being shown in section; in this the zinc plate z is seen suspended within the copper vessel C.

149. On introducing diluted acid into the copper vessel, an electric current immediately begins to circu-

late, which passes from the zinc to the copper, through the acid, and, ascending from the copper through the pivot, descends again to the zinc. Hence the zinc plate is in the condition of a conductor conveying a stream of electricity downwards, and will consequently revolve under the influence of the pole which it surrounds. The copper cylinder, on the contrary, is in the situation of a conductor conveying a current upwards, and will rotate in the opposite direction. When there is a battery on each pole of a U magnet, the two copper vessels will be seen to revolve in contrary directions, and the two zinc cylinders in directions opposite to these, and of course also contrary to each other.

150. MARSH'S VIBRATING WIRE. A copper wire W, in fig. 62, is suspended

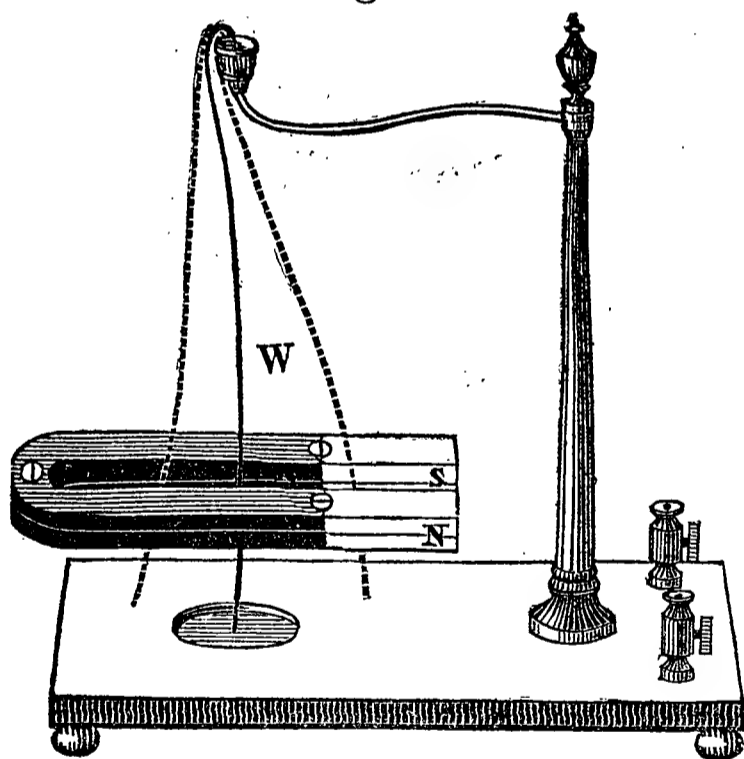

over a small basin for containing mercury excavated in the stand, by means of a brass arm supporting a mercury cup, in which the upper end of the wire rests: this mode of suspension allows it to vibrate freely, if its upper end is properly

bent. Two cups for connection with the battery communicate, one with the mercury in the excavation, the other with the cup which sustains the wire.

151. The basin being supplied with a sufficient quantity of mercury to cover the lower end of the suspended

wire, lay a horse-shoe magnet in a horizontal position on the stand, with one of its legs on each side of the wire. On establishing communication with the battery, the poles of the magnet will conspire in urging the wire either backwards or forwards between them, according to the direction in which the current flows through it, and the position of the magnetic poles. In either case, the motion will carry it out of the mercury, as shown by the dotted lines in the cut; and the circuit being thus broken, the wire will fall back by its own weight: when the current being re-established, it will again quit the mercury as before, and a rapid vibration will be produced.

152. The vibration may be made somewhat more active by raising the magnet a little from the stand, and nearly to the height of the middle of the wire. Or the magnet may be held in a vertical position with one of its poles on each side of the wire. The wire will also vibrate by the side of a single pole placed either in a horizontal or vertical position, but its motion is less active. The wire tends to revolve round the pole presented to it, as has been explained in § 79; and when suspended between a north and south pole, as in fig. 62, simultaneously around both.

153. GOLD LEAF GALVANOSCOPE. A glass tube fixed in a vertical position between the poles of a steel magnet of the U form, as shown in fig. 63, contains a narrow slip of gold leaf *c*, suspended loosely from forceps connected with a brass cup *B*, surmounting the tube. The lower end of the slip is held by another forceps communicating with the cup *E* on the stand.

When a very feeble current of electricity is transmitted through the gold leaf, it will become

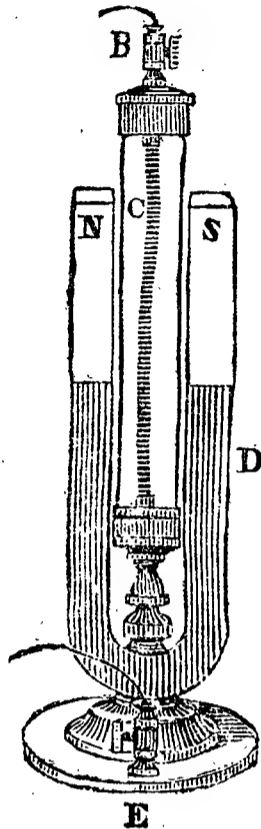
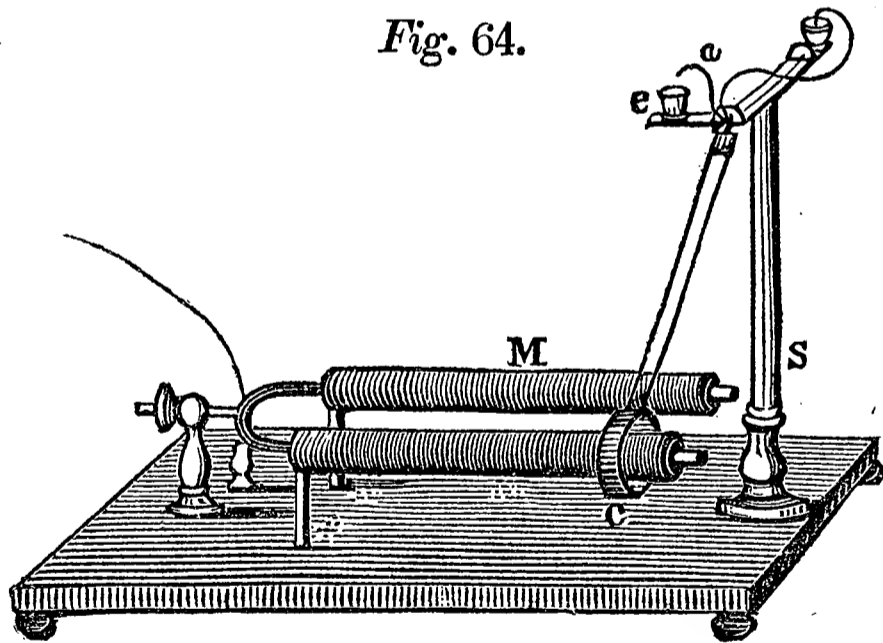

Fig. 63. curved forwards or backwards according to the course of the current: in either case tending to move away from between the magnetic poles in a lateral direction; for the same reason that causes the motion of the wire in the last described apparatus.

D The instrument does not indicate the quantity of the electrical current, as other galvanometers do, but is an exceedingly delicate test of its existence and direction. A powerful current would of course destroy the gold leaf.

154. VIBRATING MAGIC CIRCLE. An electro-magnet *M*, *fig. 64*, is supported upon a stand, in a horizontal position; and a circular coil of wire *c* is suspended from the

Fig. 64.



arm of the upright post *S* in such a manner as to allow it to pass along one of the poles of the magnet, the ring encircling the pole. On making communication with the battery, the coil will move over the pole towards the middle

of the magnet, in the same manner as De la Rive's ring already described. When it has passed some distance, the electrical circuit is broken by means of the bent wire *a*, which leaves the mercury cup *e*. The ring then falls back to its previous vertical position by the side of the post *S*, and the connection with the battery is restored. It is then again attracted by the pole of the magnet, and thus a continued vibratory motion is produced. The flow of the current through the wires of the electro-magnet is not interrupted by the breaking of the circuit in the coil *c*.

155. DOUBLE VIBRATING MAGIC CIRCLE. In the

Fig. 65.

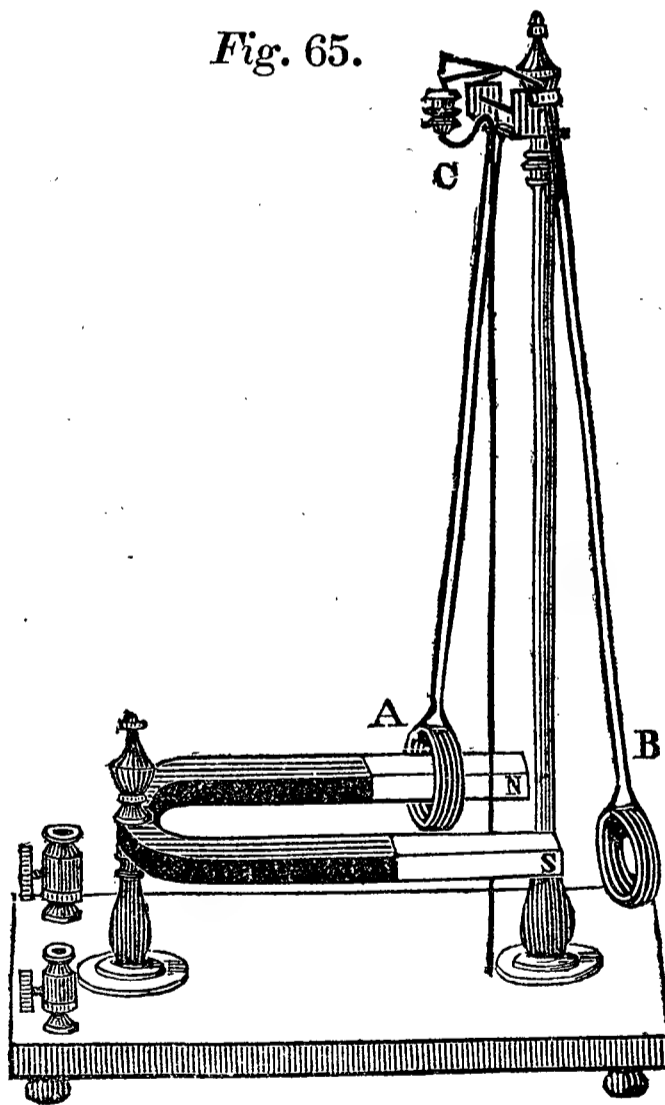

instrument represented in fig. 65 two coils *A* and *B* are employed, with a steel magnet. One end of the wire forming each coil is so bent as to dip into mercury contained in the cup *C*, when the ring hangs freely; and to be raised out of the mercury when it moves over the pole. The double wire, by which one of the coils is suspended, is somewhat longer than that which sustains the other, its axis of motion being higher in

proportion. This inequality of length occasions the vibrations of the two rings to be irregularly alternating.

156. **BARLOW'S REVOLVING SPUR-WHEEL.** The reciprocating movement in Marsh's apparatus described in § 150, may be converted into one of rotation by making

Fig. 66.

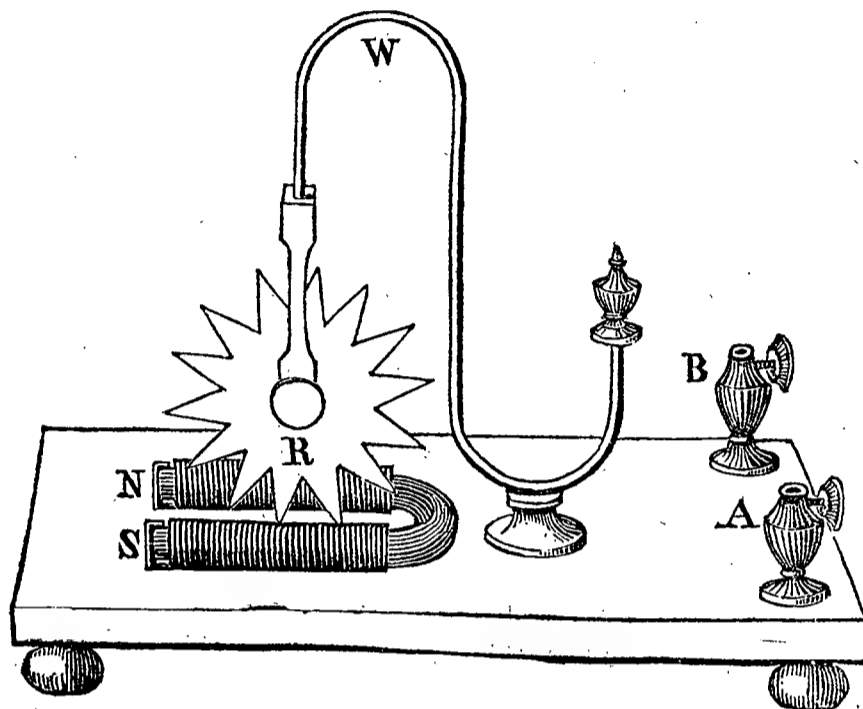

use of a copper wheel the circumference of which is cut into rays, instead of the wire. The points of the wheel *R*, fig. 66, dip into mercury contained in a groove hollowed out in the stand. A more rapid revolution will be obtained if a small electro-magnet be substituted for a steel magnet, as is shown in the cut. The electro-magnet is fixed to the stand, and included in the circuit with the spur-wheel, so that the current flows through them in succession. Hence the direction of the rotation will not be changed by reversing that of the current; since the polarity of the electro-magnet will also be reversed.

157. The course of the current is as follows. Suppose the cup *A* to be connected with the positive pole of the battery, and *B* with the negative: the electricity will flow from *A* through the wire of the electro-magnet *N S*, and thence to the mercury contained in the groove,

which is connected with one end of this wire. It will then pass along the wheel R, through any point which happens to touch the mercury, to its axis, whence it will be conveyed by the wire W, to the cup B. Under these circumstances, the ray through which the current is flowing passes forward between the poles of the magnet, like the vibrating wire in Marsh's instrument, until it rises out of the mercury. At this moment the next succeeding ray enters the mercury, and goes through the same process; and so on.

158. If the quantity of mercury is so adjusted that one ray shall quit its surface just before the next one touches it, a spark will be seen at each rupture of contact. When the machine is set in motion in the dark, so that it may be illuminated by the rapid succession of these sparks, the revolving wheel will appear to be nearly at rest; exhibiting only a quick vibratory movement, in consequence of the sparks not succeeding each other precisely at the same point. This optical illusion arises from the fact, that the electric light is so extremely transient in its duration that the wheel has not time to move to any appreciable extent during the electrical discharge; and therefore each spark shows it in an apparently stationary position. If the sparks occur at one place more frequently than at the rate of eight in a second of time, the eye cannot appreciate them separately, and the impression of a continuous light is received. For this reason the wheel is seen constantly, as if it were illuminated by a steady light, instead of an intermitting one.

159. At the bottom of the groove in the stand, the

extremity of a wire projects slightly to form the connection between the mercury and the electro-magnet. In using the instrument, care should be taken that the end of this wire and also the points of the spur-wheel are clean and bright, so that they may come into good metallic contact with the mercury.

160. **DOUBLE SPUR-WHEEL.** In this instrument there are two spur-wheels and two electro-magnets; and their arrangement is such that the current rises through the radius of one wheel, and passing along the axis descends by the other wheel.

161. **STURGEON'S REVOLVING DISC.** It is not essential to divide the wheel into rays, in order to obtain rotation. A circular metallic disc will revolve equally well between the poles of a magnet. In this case, the electric circuit remains uninterrupted during the entire revolution, and no sparks appear as with the spur-wheel.

Fig. 67.

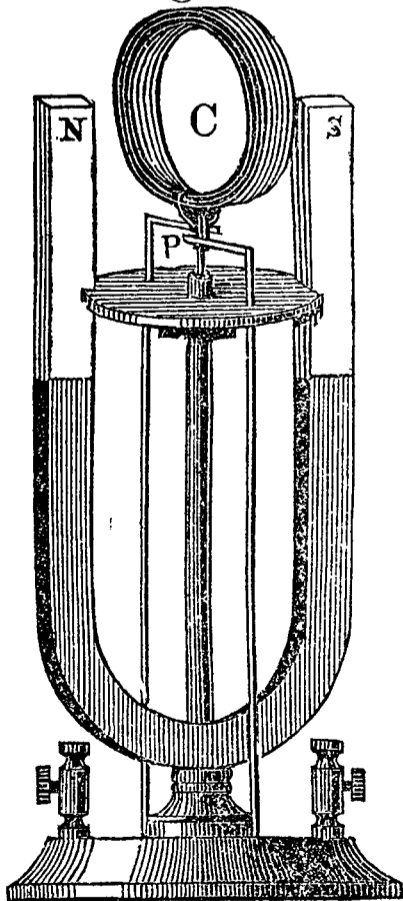

162. **PAGE'S REVOLVING RING.** This instrument consists of a U shaped steel magnet, fixed upon a stand, in a vertical position, and a circular coil of insulated copper wire C, fig. 67, so arranged as to revolve on a vertical axis between the magnetic poles. The rotation is effected in a different manner from any previously mentioned. The polarity of the ring is reversed twice in each revolution, by means of a contrivance of Dr. Page's called a *pole-changer*, which is employed

in many of the instruments to be hereafter described.

Fig. 68. The pole-changer attached to the ring is seen at P, and a horizontal section of it is shown in fig. 68. It consists of two small semi-cylindrical pieces of silver *s s* fixed on opposite sides of the axis of motion *A*, but insulated from that and from each other; to each of these segments is soldered one end of the wire composing the ring. The battery current is conveyed to the coil by means of two wires terminated by horizontal portions of flattened silver wire *W W* which press slightly on opposite sides of the pole-changer, whose segments must be so arranged that the direction of the current in the ring may be reversed at the moment when its axis is passing between the poles of the magnet.

163. On placing the ring with its axis at right angles to the plane of the poles, and making connection with a battery, one extremity of the axis, or in other words, one face of the coil, will acquire north polarity, and the other south polarity, in the same manner as De la Rive's ring; the action of the magnet will now cause it to move round a quarter of a circle in one direction or the other according to the course of the current, so as to bring its poles between those of the magnet. In this position it would remain, were it not that as soon as it reaches it, the pole-changer, which is carried round with it, presents each of its segments to that stationary silver spring which was before in contact with the opposite segment. By this movement the current in the ring is first interrupted for a moment, and as the ring passes on is immediately renewed in the contrary direction, thus reversing the

polarity. Each end of the axis being now repelled by the magnetic pole which previously attracted it, the coil turns half way round so as to present its opposite faces to the poles. At this point the direction of the current is again reversed, causing the motion to be continued in the same direction; thus producing a rapid revolution. Instead of a ring of large diameter, the wire may be coiled into a long helix of small diameter, which will rotate in the same manner.

164. REVOLVING RECTANGLE. This instrument is similar in principle to the preceding, a rectangular coil

Fig. 69.

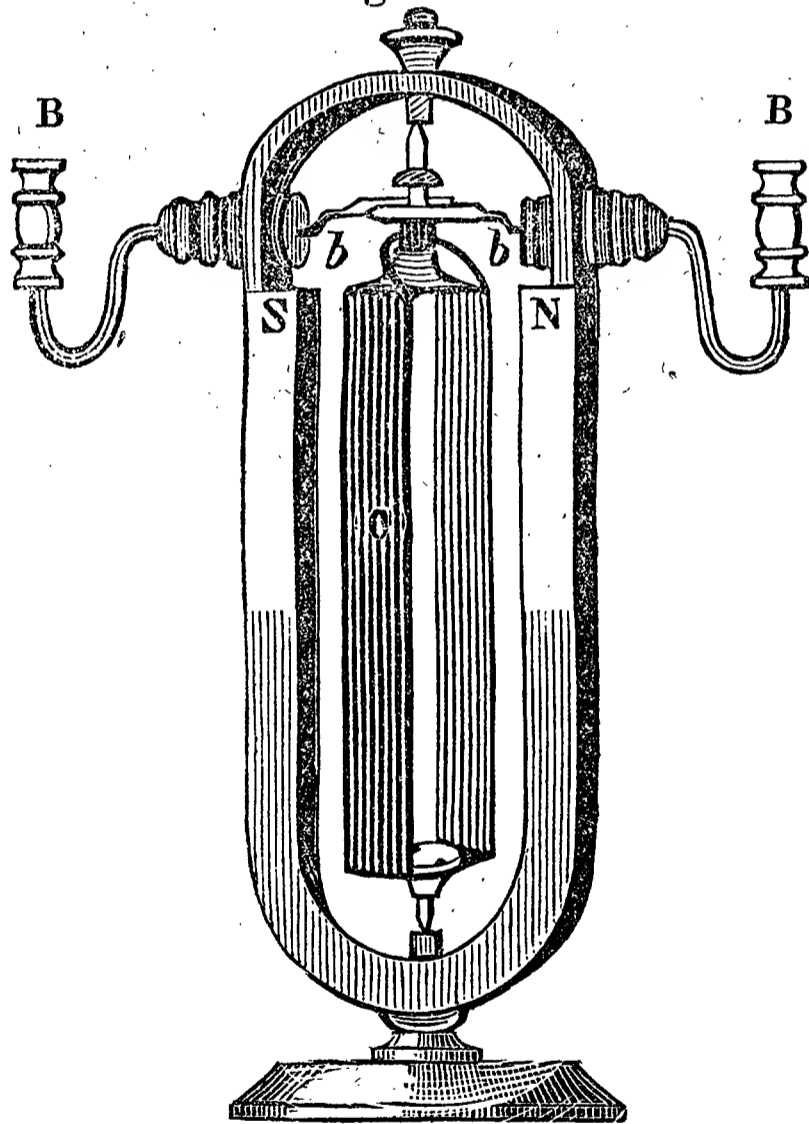

of wire C, fig. 69, being substituted for the ring. The rotation is much more rapid in consequence of the proximity of the rectangle to the magnet, not only near

its poles, but throughout the greater part of its length. By this means the great speed of eight or ten thousand revolutions in a minute may be attained. In the cut, the two silver springs which press on the pole-changer are seen at *b b*, each of them attached to a stout brass wire, proceeding from one of the cups *B B*, for battery connection; these wires pass through the brass arch surmounting the U magnet, but are insulated from it.

165. PAGE'S ROTATING MULTIPLIER. This instrument consists of a permanent bar magnet fixed in a horizontal position within a rectangular coil of wire, which is so arranged as to revolve around it on a vertical axis. On transmitting a galvanic current through the wire, the mutual action between it and the magnet causes the coil to place itself at right angles with the magnet: at this point the pole-changer, with which it is provided, reverses the current, and the coil continues to move on in the same direction, revolving as long as the battery connections are maintained.

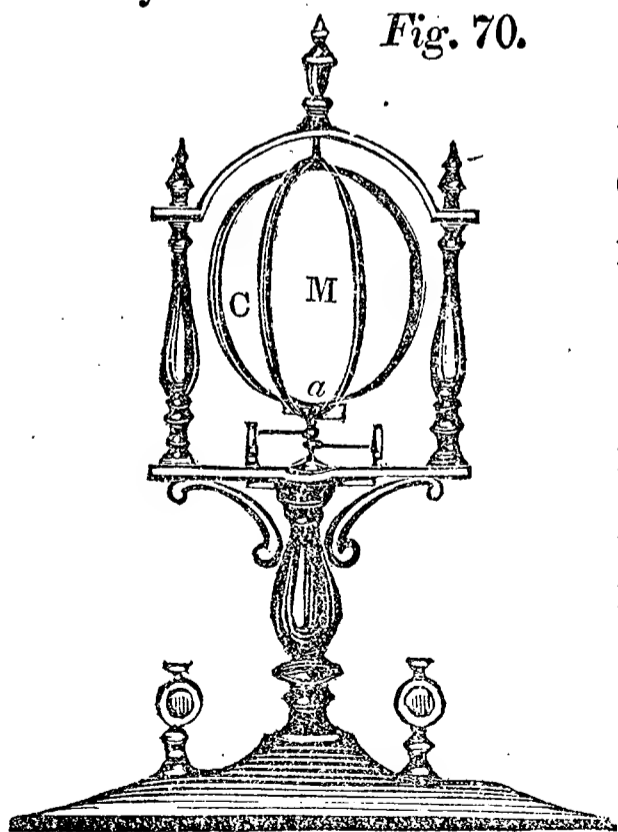

Fig. 70.

166. REVOLVING RING AND MAGNET. This consists of a circular coil of wire *C*, fig. 70, fitted to revolve on a vertical axis, which carries a pole-changer at *a*. So far it resembles Page's Revolving Ring. But in this case the magnet *M* rotates also: for this purpose it is made of thin steel, and bent into a circular form, with its poles nearly in

contact and connected by a strip of brass. The circle thus formed is a little larger than the coil, and revolves freely around it on a vertical axis. A peculiar arrangement is required in order to transmit the voltaic current to the pole-changer belonging to the ring. The springs which press upon it are connected with two small cylinders of silver fixed on the axis of motion of the magnet and insulated from it, one being a little below the other; or a part of the axis itself being made cylindrical may answer for one of them: the wires proceeding from the brass cups on the stand press upon these cylinders. In this manner the current is conveyed to the springs of the pole-changer in a constant direction notwithstanding that they are carried round with the magnet in its revolutions. When the current is transmitted through the coil, the mutual action between it and the magnet causes them both to revolve, but in contrary directions; on the well known mechanical principle that action and reaction are always equal and opposite to each other.

167. The arched flame obtained between two charcoal points attached to the poles of a powerful battery, as represented in fig. 11, will be thrown into a rapid rotary motion when a magnetic pole is placed near it. This effect may also be very satisfactorily shown by pressing one of the battery wires firmly upon a steel magnet, and bringing the other wire up to one of its poles. The flame which may now be obtained by withdrawing this wire a little, will rotate in one direction if drawn from the north pole, and in the opposite direction if from the south. When the magnet is connected with the negative end of the voltaic series, the flame

drawn from its north pole revolves from left to right, in the direction of the hands of a watch.

MOTIONS PRODUCED BY THE REVERSAL OF THE POLARITY OF AN ELECTRO-MAGNET.

168. **RITCHIE'S REVOLVING MAGNET.** A steel magnet of the U form is supported upon a stand in a vertical position, its poles being uppermost. The revolving piece is a small straight bar of soft iron wound with insulated wire; it has a pivot projecting downwards from its under surface, which enters a deep pivot-hole on the top of an upright rod so fixed that the iron bar may rotate horizontally between the poles of the U magnet. The two extremities of the wire surrounding this electro-magnet descend into a circular basin of ivory for containing mercury, attached to the upright rod a little below the revolving bar. This basin is divided into two separate cells by two low partitions of ivory, so arranged that when the electro-magnet is passing between the poles of the steel magnet the ends of the wire may be moving across the partitions and just above them. On supplying the cells with a proper quantity of mercury, its surface will be found to curve downwards on every side towards the ivory, so that its general level will be higher than the partitions; thus allowing the extremities of the wire to be immersed in it except when passing across them. A wire connected with a brass cup, for making communication with the battery, projects into the mercury in each compartment of the basin.

169. On transmitting the voltaic current, when the

bar is at right angles to the plane of the magnet, it will immediately acquire a strong polarity. Its north pole will then be attracted by the south pole of the steel magnet and repelled by its north pole. The south pole of the bar, on the contrary, will be repelled by the similar pole of the upright magnet, and attracted by its opposite pole. These four forces will conspire in bringing the electro-magnet between the poles of the U magnet; as soon as it reaches this position, the ends of the wire will quit their respective mercury cells, and by the momentum of the bar, which at this moment loses its magnetism, will be carried across the partitions, so that each will dip into that portion of the mercury which the other has just left. This will renew the circuit and restore the polarity of the electro-magnet, but in the reverse direction. Each pole of the bar will now be repelled by that pole of the permanent magnet which it has just passed, and attracted by the opposite one; it will thus continue to move on, its polarity being reversed twice in each revolution.

170. At the moment when the wires quit the mercury to pass across the partitions, a spark is seen. When the machine is put in motion in a dark room, these sparks give rise to an optical illusion of the same character as that mentioned under the head of Barlow's Revolving Spur-Wheel, causing the bar to appear at rest in the position it is in when the sparks are emitted. The points of the wires which dip into the mercury should be kept clean and well amalgamated. The tendency of the mercury to be drawn over the partitions may be

partially prevented by a little water on its surface, which however diminishes the brilliancy of the sparks.

171. PAGE'S REVOLVING MAGNET. In this instrument, represented in fig. 71, the polarity of the electro-

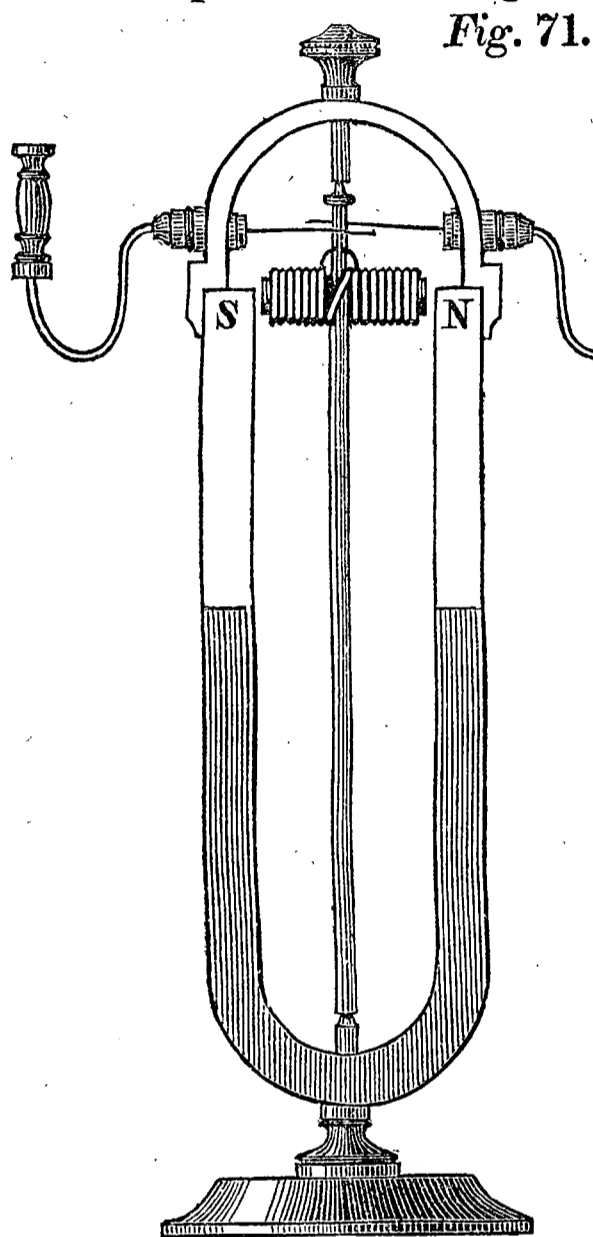

Fig. 71.

magnet is reversed, not by means of mercury, as in the one last described, but by Dr. Page's pole-changer, § 162, the segments of which are so arranged that the poles of the revolving bar may be changed at the moment when it is passing the poles of the fixed magnet. The silver springs which press upon the pole-changer are attached to two stout brass wires which pass through the brass arch surmounting the U magnet, but are insulated from it by the

intervention of ivory or horn; each of these wires supports a brass cup for connection with the battery. In this way a more rapid revolution is obtained than with Prof. Ritchie's arrangement, but the fine sparks afforded by that do not make their appearance. A still more rapid rotation may be produced, both in this and in Ritchie's instrument, by employing a U shaped electro-magnet in place of the stationary steel magnet. In this case, the

revolution is not reversed by changing the direction of the current, as it is when a steel magnet is used, since the poles of both electro-magnets are reversed at the same time, and their relative polarity remains the same.

172. **ROTATING BELL ENGINE.** The general construction of this instrument is similar to the preceding, the U magnet, however, being inverted, so that the

Fig. 72.

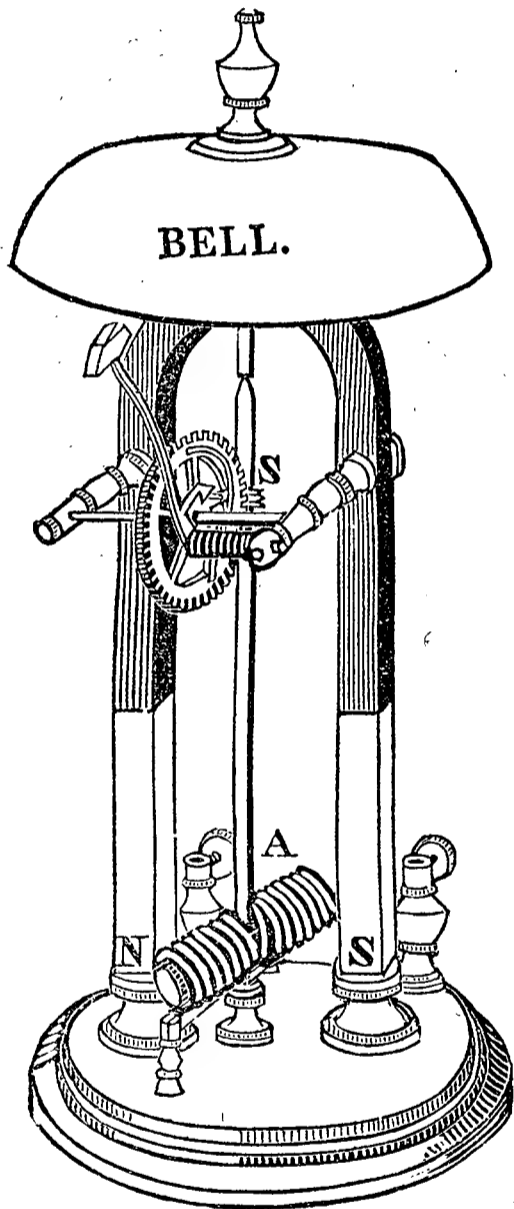

revolving electro-magnet A, fig. 72, is near to the stand; the pole-changer being attached to the axis below it. There is, in addition, an arrangement for striking a bell fixed above the magnet. To the axis of the revolving bar is attached an endless screw S; this acts upon a toothed wheel, which is provided with a pin projecting laterally, for the purpose of moving the hammer of the bell. As the wheel turns, the pin presses upon the handle of the hammer, raising it from the bell until it is released by the pin at a certain point of the revolution; when a spiral spring fixed to the handle

impels the hammer against the bell.

173. If the wheel has sixty-four teeth, the electro-magnet must revolve sixty-four times in order to produce one revolution of the wheel, and consequently

one stroke upon the bell. By counting the number of strokes in a given time, the velocity of the rotating bar may be measured: it often makes one hundred or more revolutions in a second. In order that the motion of the wheel may raise the hammer, it is necessary to transmit the battery current so that the bar may rotate in the proper direction.

174. **ELECTRO-MAGNETIC SEASONS MACHINE.** In the instrument shown in fig. 73, the revolving magnet A imparts motion to an astronomical machine, representing the rotation of the earth and moon round the sun. The earth and sun revolve round a common centre of motion near the latter, which is represented by a gilt ball S; the earth also rotates on its axis. The axis of the earth has its proper obliquity with respect to the ecliptic, and preserves its parallelism, pointing in the same direction during the whole revolution. These circumstances oc-

Fig. 73.

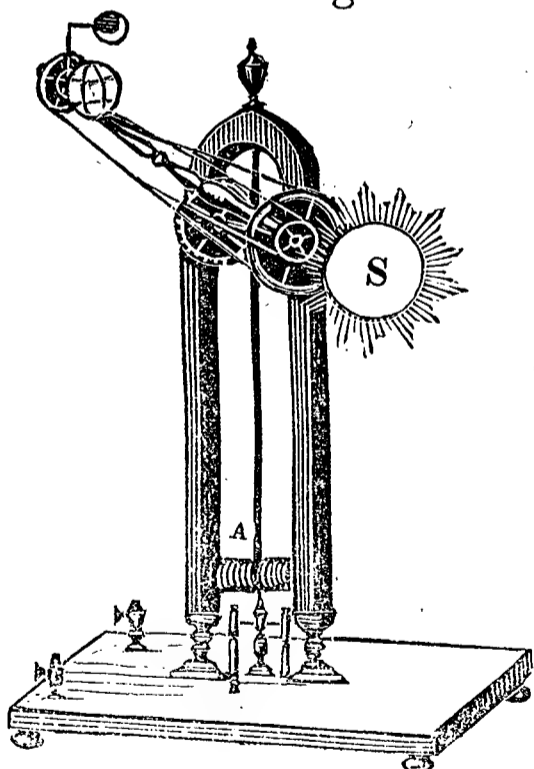

casione the north pole to be inclined towards the sun in one half of the orbit, and the south pole in the other, the degree of inclination constantly varying. This, in the case of the real earth, is the cause of the variation of the seasons and of the unequal length of the day and night. The moon is also seen to revolve around the earth, attending it in its course round the sun.

175. **DOUBLE REVOLVING MAGNET.** In this instrument, represented in fig. 74, there are two semicircular

electro-magnets of the same size, both of which have

Fig. 74.

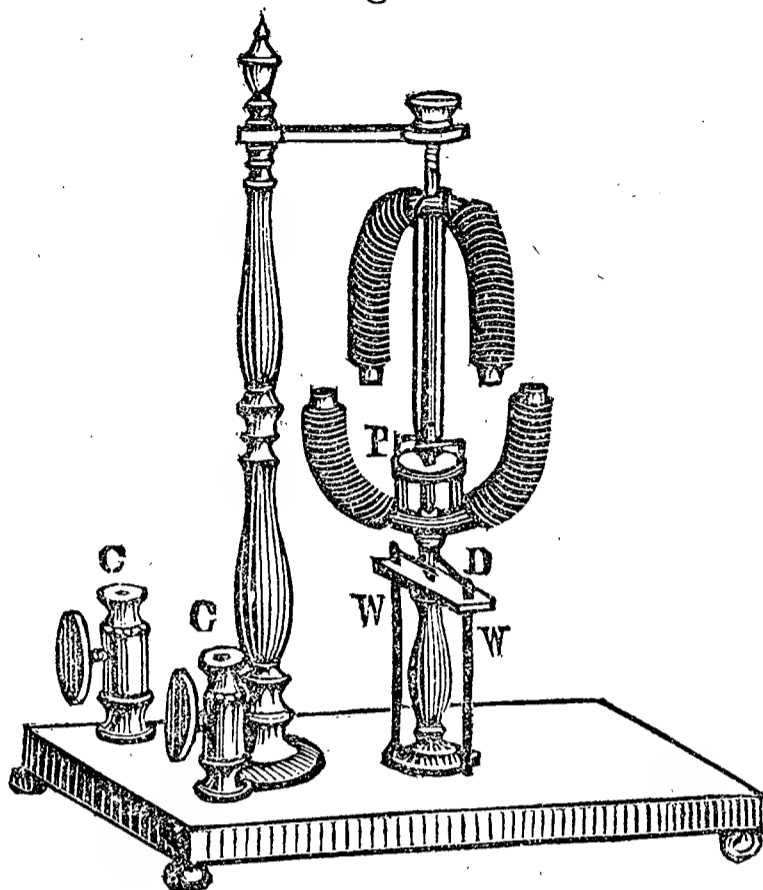

freedom of motion. The lower semicircle is supported by a pivot entering the upright pillar below it; its own axis is hollowed to receive the pivot on which the upper semicircle revolves. At D, in the figure, is seen a contrivance for conveying the current in a constant direction, of the same

Fig. 75.

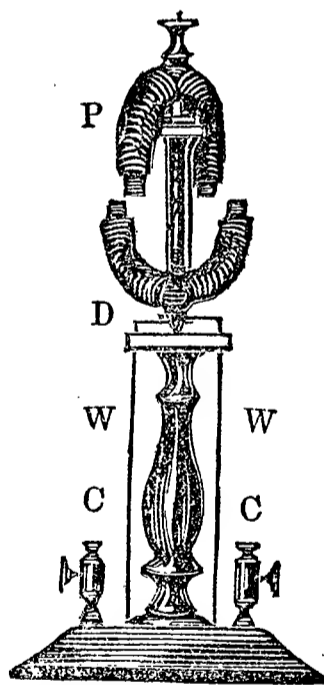

kind as that applied to the Revolving Ring and Magnet, § 166, and which therefore need not be again described.

176. Fig. 75 represents another form of the instrument, in which the upper electro-magnet is supported on the lower one without the aid of the brass arm and pillar, seen in the preceding cut; thus admitting of the use of a small circular stand. This figure is lettered in correspondence with the above.

177. The cups C C being connected with the battery, the current will flow along one of the wires W W, to one of the silver rings secured to the axis at D, thence through the wire enveloping half of the lower electro-magnet, to one of the springs playing on the pole-changer

at P; it then traverses the wire surrounding the upper electro-magnet, with which the pole-changer is connected. Descending now to the opposite spring at P, it circulates around the other half of the lower semicircle, and thence back to the battery. By this means the poles of the upper semicircle are reversed twice in each revolution, while the polarity of the lower one remains unchanged. The upper electro-magnet will consequently rotate in the same manner as those in the instruments we have just described, while the lower one will move in the opposite direction, on the principle of reaction; its own poles being of necessity attracted and repelled with equal force while they are attracting and repelling those of the upper one. It would revolve as rapidly as the other, were it not that the friction of its axis is doubled in consequence of sustaining the weight of both electro-magnets. By holding the other stationary, however, the lower one will acquire a considerable velocity, which it will retain for a while when its fellow is released; their rapid motion causes them to present the appearance of a hollow sphere.

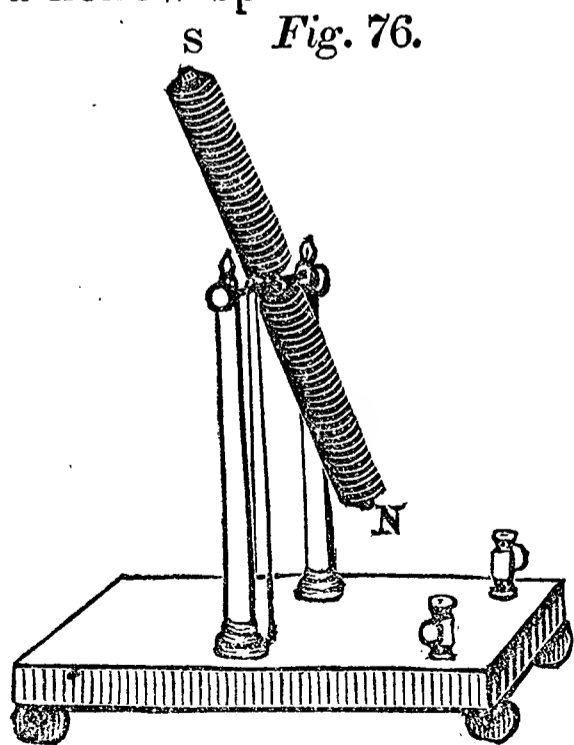

178. MAGNET REVOLVING BY THE EARTH'S ACTION. AS the earth itself exhibits magnetic polarity, an electro-magnet may be made to revolve by its influence; though, in consequence of the feebleness of the action, the instrument must be constructed with some delicacy. A small electro-magnet N S, fig. 76, is so

supported as to have freedom of motion in a vertical plane like the dipping needle, a pole-changer being secured on its axis of motion. The springs which press upon the pole-changer should be disposed in such a manner that the polarity of the bar may be reversed when in the course of its revolution it reaches the line of the *dip*.

179. On placing the electro-magnet horizontally in the magnetic meridian, that is to say, with its extremities directed north and south, and transmitting the voltaic current, its north pole (in this hemisphere) immediately inclines downwards towards the earth, in the same manner as that of the dipping needle. As soon as it arrives at the line of the dip, its poles are reversed, and it continues to move on in the same direction as long as the battery connections are maintained, revolving with a moderate velocity. In high latitudes it will be sufficient to arrange the pole-changer so as to reverse the poles of the bar when it becomes vertical.

180. By placing a steel magnet in a proper position near the revolving bar, it will rotate with much greater speed than by the action of terrestrial magnetism alone; its motion may be reversed, notwithstanding the opposing influence of the earth, by disposing the permanent magnet in a suitable manner.

181. The electro-magnet may be so fitted as to revolve horizontally instead of vertically. In this case the springs of the pole-changer must be arranged in such a manner as to reverse its polarity when it assumes the position of the compass-needle, pointing north and south.

MOTIONS PRODUCED BY THE ALTERNATE DESTRUCTION AND RENEWAL OF THE POLARITY OF AN ELECTRO-MAGNET.

182. PAGE'S REVOLVING ARMATURE. A small bar of iron, not wound with wire, is fitted to revolve horizontally just above the poles of an electro-magnet of the U form, fixed in a vertical position; as seen in fig. 77, where A is the iron bar, and M the electro-magnet. The rotation is effected by means of the following arrangement. To the axis of motion of the iron bar is affixed what is called a *breakpiece*, made by filing away two opposite sides of a small solid cylinder of silver. Upon the narrow prominent portions thus left, play two

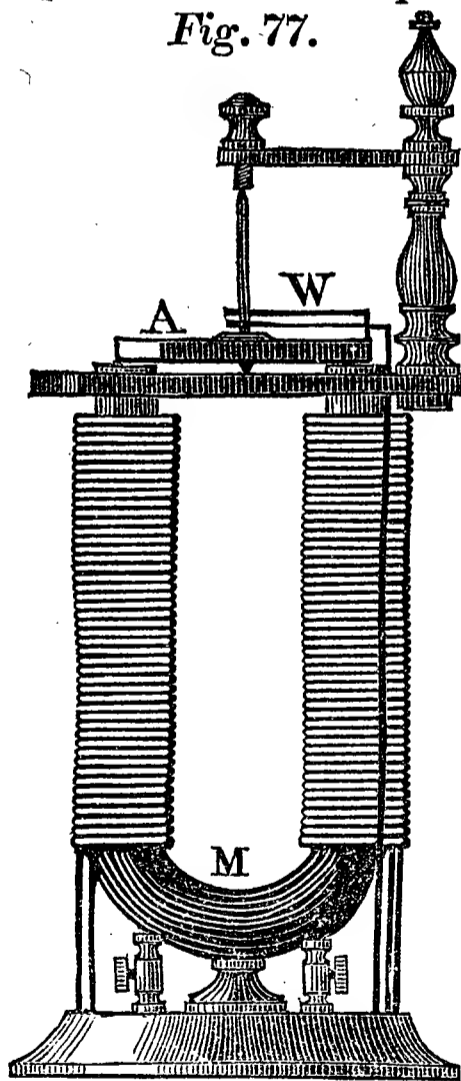

Fig. 77.

silver springs, shown at W in the cut, opposite to each other. One of these springs is connected with a brass cup on the stand; the other communicates with one extremity of the wire enveloping the electro-magnet, the other end of this wire being fixed to a second cup on the stand. The breakpiece is so arranged as to release the springs from their bearing just as the armature passes over the poles; and to restore them to it again when it has moved on somewhat more than a quarter of a circle, so as to be a little inclined from a position at right angles to the plane of the magnet.

183. On placing the bar in this position and connecting the cups on the stand with a battery, the electro-magnet will become charged, and consequently will attract the armature towards its poles; as soon as it reaches their plane, the springs leave the projecting parts of the breakpiece, and the current is cut off. The polarity of the magnet is now destroyed, and it ceases to attract the armature; which moves on by the momentum it has acquired, until it passes a little beyond a position at right angles to the plane of the magnet. At this point the springs again come in contact with the breakpiece, and the flow of the current is renewed. The attraction now exerted by the poles gives a new impulse to the armature, and the circuit being again broken when it reaches their plane, it continues its motion in the same direction, revolving with great speed.

184. In the original form of the breakpiece, one of the springs pressed constantly upon a portion which was left cylindrical; but this is disadvantageous where only one electro-magnet is to be charged, as it increases the friction. Care should be taken that the springs are in such a state of tension as to open and close the circuit at the proper points, as indicated in the above description. The motion of the bar will not be reversed by changing the direction of the current.

185. **HORIZONTAL REVOLVING ARMATURES.** In this instrument there are several armatures fixed to the circumference of a vertical brass wheel, and parallel to its axis; in fig. 78, three are represented, each of them marked A. On the poles of the electro-magnet M is secured a brass plate, from which rise two brass pillars

to support the axis of the wheel: as the wheel turns, the iron bars pass in succession over the poles with their

Fig. 78.

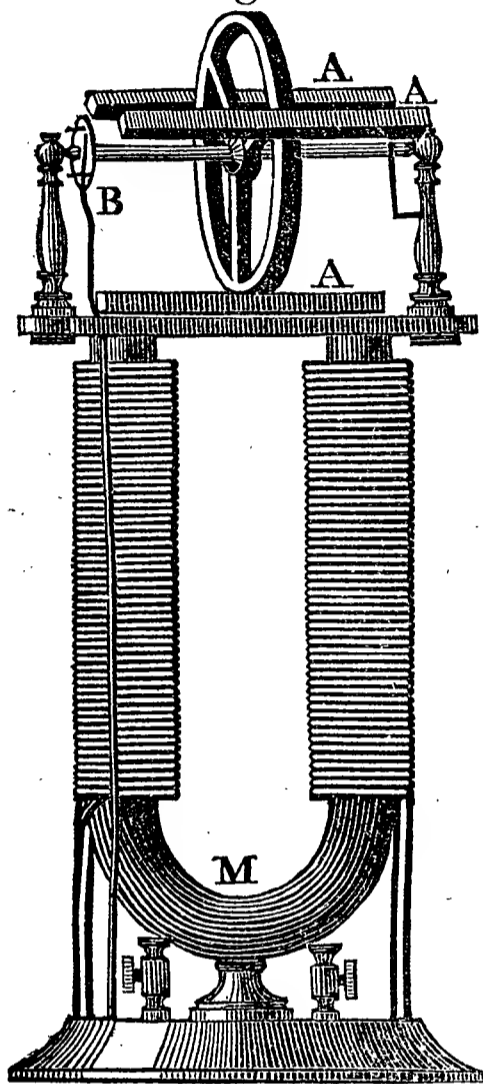

extremities very near to them. At B, on the shaft of the wheel, but not insulated from it, is the *breakpiece*, consisting of a small metallic disc, from which project in a lateral direction, several pins, equal in number to the iron bars; or the disc may be furnished with a corresponding number of teeth. A silver spring connected with one end of the wire surrounding the electro-magnet plays upon these pins or teeth; the other end of this wire is soldered to the iron of the magnet, which brings it into metallic communication with the shaft by means of the brass

plate and pillars. Or the wire may be terminated by a second spring pressing upon a cylindrical part of the axis.

186. The breakpiece is arranged in such a manner that the electro-magnet will be charged when any one of the iron bars is brought near it by the motion of the wheel. The approaching armature is then attracted towards the poles; when it arrives at the plane of the magnet the current is cut off, in consequence of the corresponding pin or tooth releasing the silver spring from its bearing. The armature being no longer attracted, the wheel moves on by its momentum till the next bar comes into the same position, causing the

magnet to be recharged; it is then attracted in its turn, and passes on like the preceding one.

187. The spring playing on the breakpiece must be so disposed that the circuit shall be broken when each bar reaches the poles, and not be renewed again until it has passed to a greater distance from them than that between the next succeeding bar and the poles, or it will be attracted back again, preventing the continuance of the motion.

188. In this and many of the instruments of the same class, an electro-magnet of a peculiar construction may be employed with advantage. Instead of a solid bar within the helix, there is an iron tube filled with wires of the same metal; the tube is sawed open on one side throughout its whole length. By this arrangement the magnetism is acquired and lost with greater rapidity than by a solid bar.

189. PAGE'S RECIPROCATING ENGINE. Two U

Fig. 79.

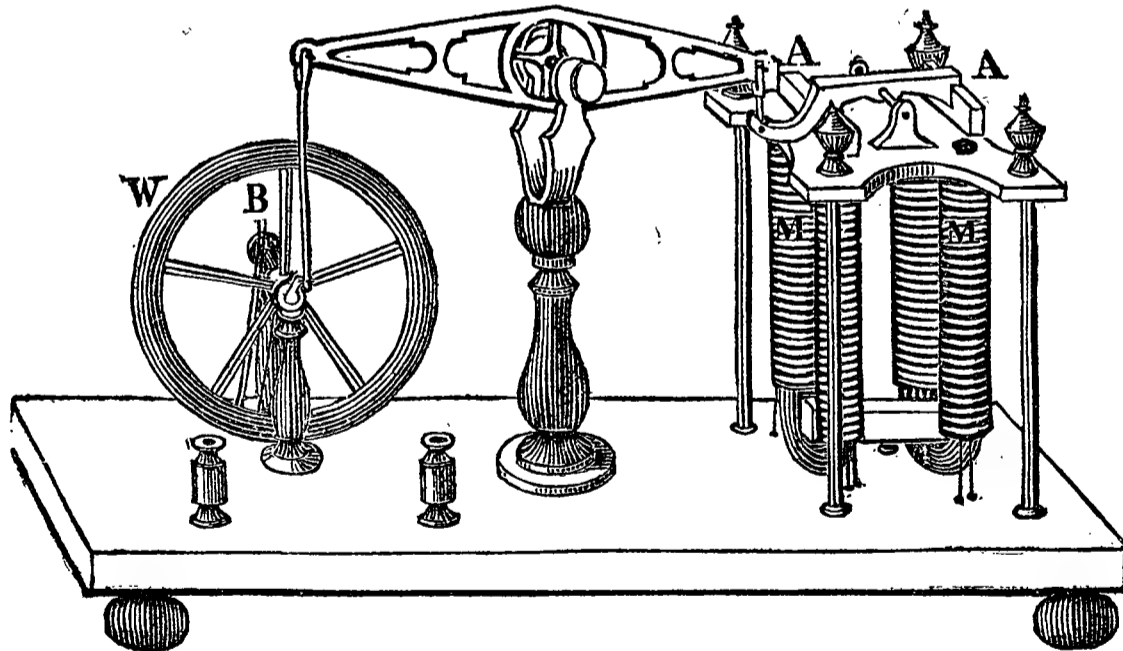

shaped electro-magnets, M M, fig. 79, are firmly secured in a vertical position on a stand, the four poles appearing just above a small wooden table. The two armatures,

ELECTRO-MAGNETIC MOTIONS.

A A, connected together by a brass bar, move upon a horizontal axis in such a manner that while one is approaching the poles of the magnet over which it is placed, the other is receding from those of the other magnet. The brass bar is connected with one extremity of a horizontal beam, the other end of which communicates motion by the intervention of a crank to the fly-wheel W. To the axis of the fly-wheel at B is fixed the silver breakpiece, by means of which the magnets are alternately charged. It is similar to the one described under Page's Revolving Armature, § 182; there are, however, three springs, one playing upon a cylindrical portion, the others upon two dissected portions of the breakpiece. Each magnet being charged in succession, the armatures are attracted alternately, communicating a rapid reciprocating motion to the beam and consequently a rotatory one to the fly-wheel.

190. UPRIGHT RECIPROCATING ENGINE. In this in-

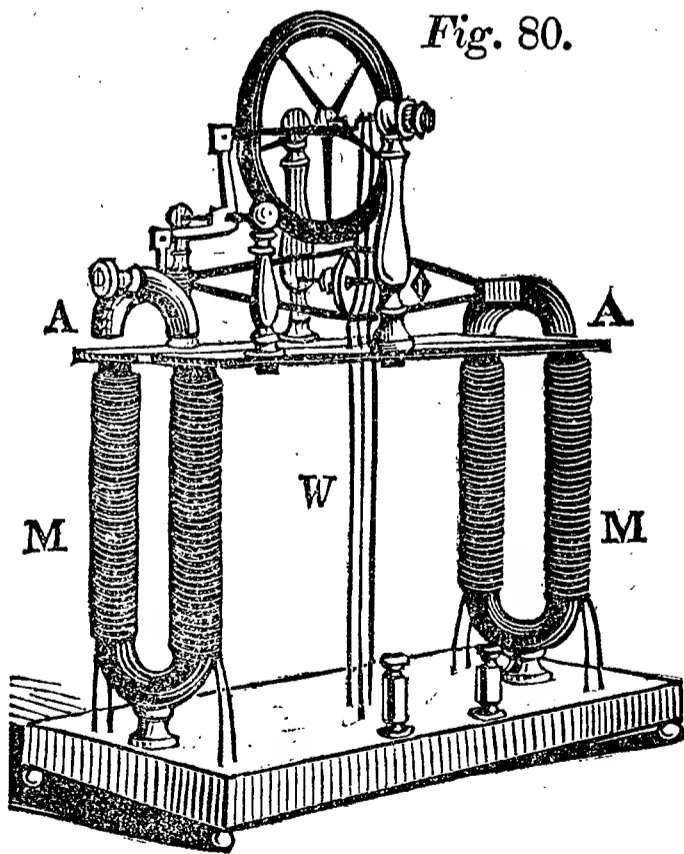
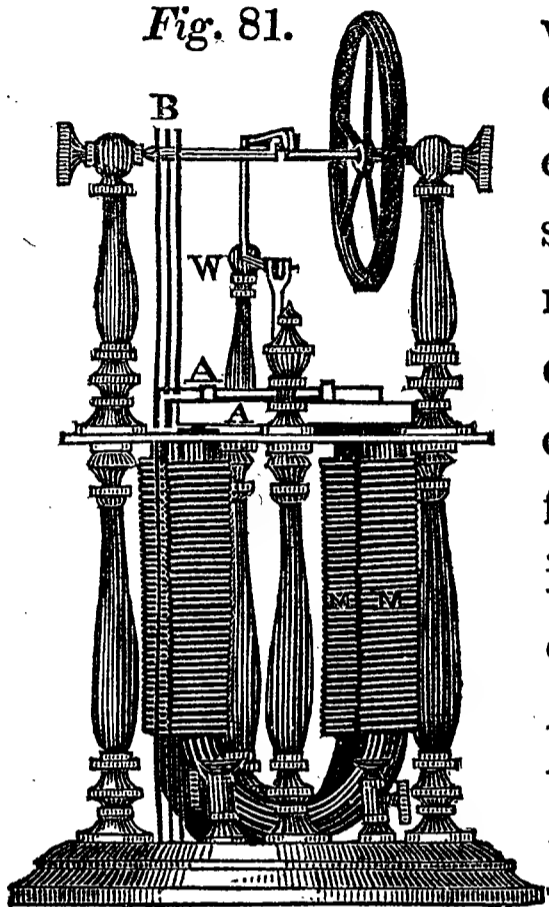

Fig. 80.

strument, represented in fig. 80, the armatures A A, which are semicircular instead of being straight as in the one last described, are each affixed to one extremity of a vibrating beam, which imparts motion to a balance wheel placed above the magnets. At W are seen the three springs which play upon a break-

piece fixed to the axis of the wheel. The motion is produced in the same manner as in Page's Engine.

191. Fig. 81 represents another form of the instrument which is more compact. The



electro-magnets, M M, are secured to a circular stand; and the straight armatures, A A, are connected by a short beam, which communicates motion by means of a bent lever and crank to the fly-wheel. In other respects its construction is similar to that of the preceding instrument. At B is the breakpiece with the three silver springs, marked W, pressing upon it.

192. RECIPROCATING BELL ENGINE. Two electro-magnets of the U form, M M, fig. 82, are supported in a horizontal position, with a single armature A fitted to

Fig. 82.

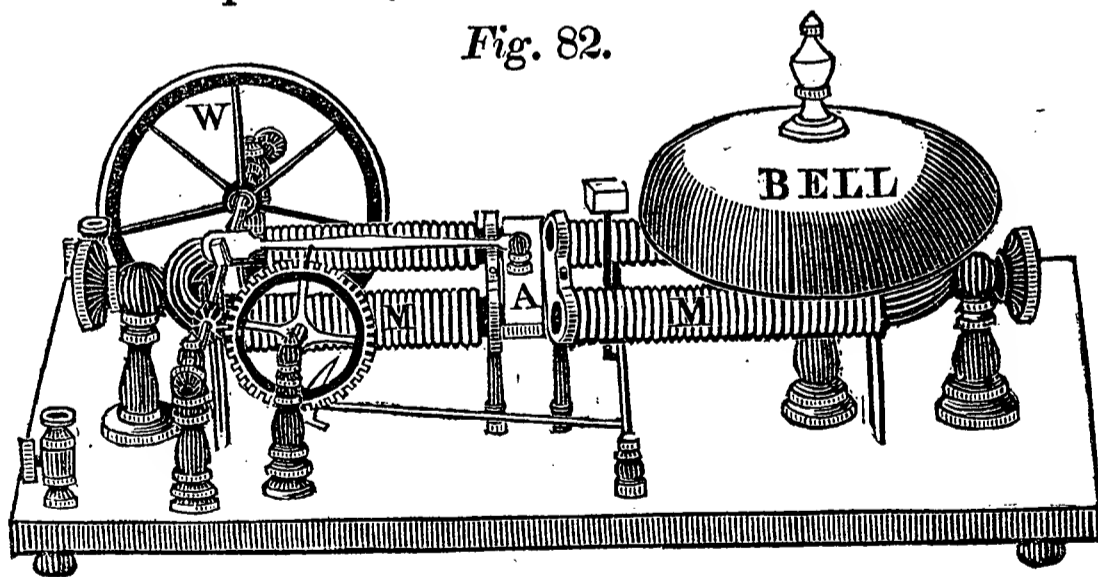

vibrate horizontally between them. This armature imparts motion by means of a crank to the fly-wheel W, and at the same time to machinery by which a hammer

is made to strike the bell placed over one of the magnets. The breakpiece is the same as in the three preceding instruments.

193. When the battery connections are made with the cups on the stand, one of the magnets will be charged, provided the breakpiece is in such a position with regard to the springs as to complete the circuit. The armature will now be attracted towards the charged poles. Just before it reaches them, the movement of the breakpiece will interrupt the current in the magnet, destroying its polarity, and then cause the current to be transmitted through the opposite one; this will become charged in its turn, and attract the iron bar A, which will thus vibrate backwards and forwards between the two magnets.

THERMO-ELECTRIC REVOLUTIONS.

194. THERMO-ELECTRIC REVOLVING ARCH. It has been shown that when a galvanic current flows through

Fig. 83.

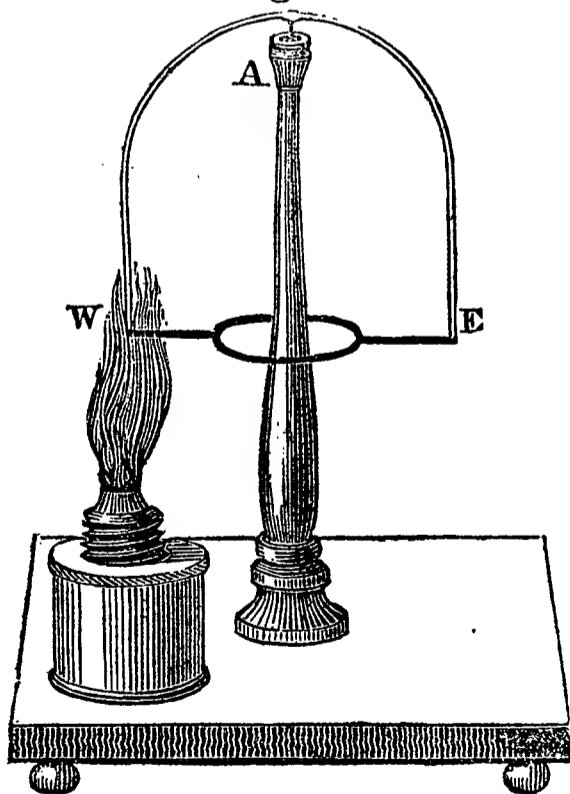

a helix, such as De la Rive's ring, § 130, its faces acquire polarity, and if free to move, arrange themselves north and south. In fig. 83 there is a stand supporting an upright brass pillar with an agate cup at the top. On this is balanced by a pivot at A an arch of brass wire, the two ends of which are connected by a German silver wire encircling the pillar.

195. If the stand be arranged according to the points of the compass, and one of the junctions of the brass and German silver be heated by a spirit lamp on the east side of the stand at E, a thermo-electric current will be set in motion from the German silver through the heated junction to the brass, and back through the arch to the German silver. The current thus established gives polarity to the faces of the arch, as if it were an heliacal ring; circulating in such a direction that the face which is turned towards the *north* exhibits south polarity. Since the magnetic pole of the earth there situated is itself a south pole, as has been stated in § 102, similar poles will be presented towards each other, and the arch will be obliged to make a semi-revolution on its axis in order to present its northern face to this pole. This movement will bring the other junction into the flame, and a current will be produced opposite to the former one, which will change the polarity of the arch and oblige it to move on through another semi-revolution. Thus the currents are reversed, and slow rotation ensues. This is probably the most delicate reaction between the magnetism of the earth and a current of electricity which has ever been observed.

196. If the lamp be put to the south of east, the heated junction of the arch will move round by the south; if it be put to the north of east, the heated junction will move round by the north; just as a compass-needle, if its north pole is made to point south, will return to its natural position either by the east or west, if it is inclined to the one or the other. If the spirit lamp be placed exactly west, or at W in the figure, the current which is excited will tend to keep the arch stationary, by

causing the face which exhibits north polarity to be directed towards the *south magnetic pole* of the earth.

197. THERMO-ELECTRIC REVOLVING ARCH ON U
Fig. 84.

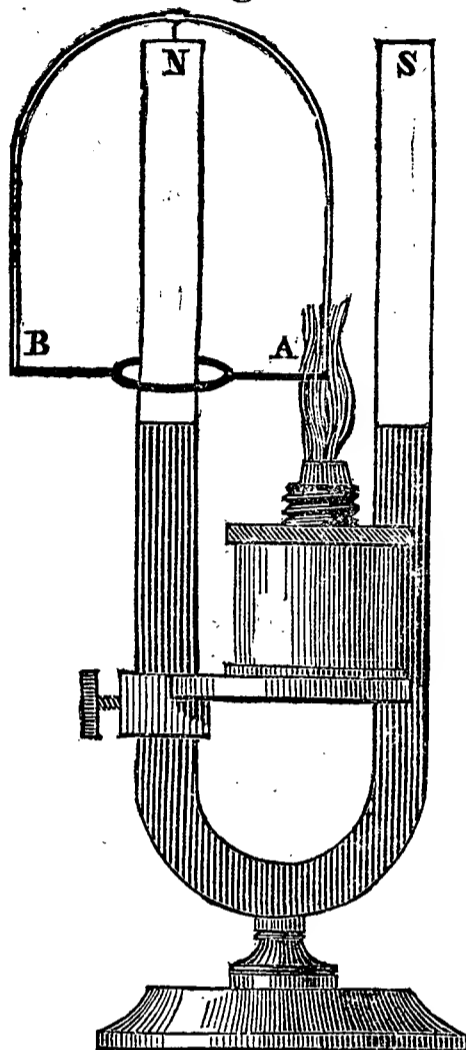

MAGNET. If a thermo-electric arch, A B, fig. 84, similar to the one just described, be balanced on one of the poles of a U magnet, the reaction between the polarity induced in it, by heating one of its junctions, and the magnetism of the opposite pole of the magnet, will be much more energetic than in the former case with the earth. It resembles, in principle, Page's Revolving Ring, § 162, only that it is attracted and repelled by a single pole instead of two, the pole on which it is supported having no influence upon it.

In this and other instruments of the same kind, the upper part of the arch may, with equal advantage, be of silver instead of brass.

198. The most favorable position for the lamp is not that represented in the figure, but at a right angle with the line connecting the two poles, and in a line with the pole on which the frame is mounted; or in a situation analogous to the east side of the stand of the last described instrument. By varying the lamp to one side or the other of this position, the arch will revolve in either direction, as before. On the opposite side of the pole the lamp would have no tendency to produce revolution; though if the arch were mounted on the

south pole, the lamp should be on the farther side of the magnet, and in a line with that pole, in order to cause rotation.

199. THERMO-ELECTRIC REVOLVING WIRE FRAMES. This instrument, represented in fig. 85, consists of two

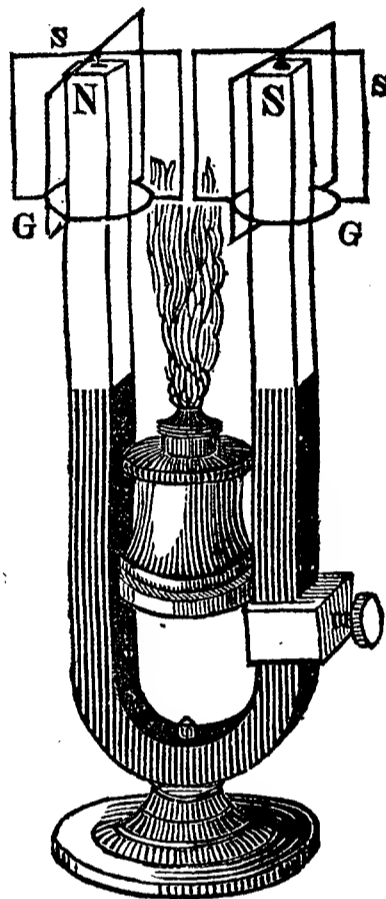

frames mounted upon the poles of a U magnet. These frames are formed of two arches, or rather rectangles, similar in construction to that in the last instrument, crossing each other at right angles; and they act on the same principle as that, the second rectangle only contributing to the rotation produced by the first. In each individual rectangle the current is reversed every half revolution. These were formerly made of silver and platinum, but since the recent observation of the superiority of German silver in combination

with brass or silver, these substances are employed. The lower horizontal portions of the frames, marked G G in the cut, are composed of German silver, and the other parts, s s, of silver. A frame is usually mounted on each pole; the attractions and repulsions of each frame proceeding altogether from the opposite pole. In order to heat the junctions of both frames at once, the lamp is placed between the two poles, by which there is a loss of attraction and repulsion to each frame through the distance of 90° , in which the heat would act, if two lamps were employed at right angles to the line of junction of the poles.

200. THERMO-ELECTRIC ARCH ROTATING BETWEEN THE POLES OF A U MAGNET. Fig. 86 represents a thermo-electric arch mounted upon a brass pillar between the poles of a horse-shoe magnet; the circular part G

Fig. 86.

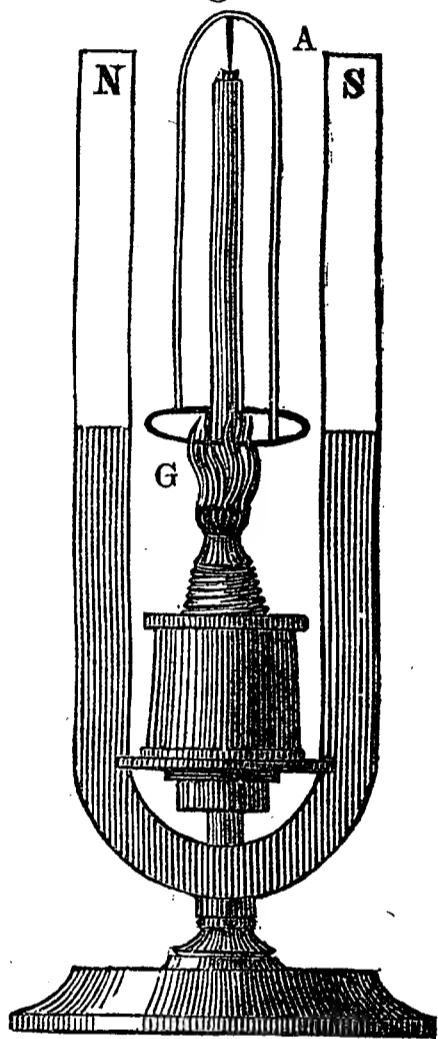

is of German silver, and the upper part A of silver. In this case, both poles conspire in producing revolution, the motion of the arch depending upon the same principle as that of Page's Revolving Ring; the different mode of reversing the current in this instrument, however, causes the arch to rotate in either direction when the lamp is in front of the magnet, and to remain at rest when the lamp is on the other side. A stand to support the lamp slides on the brass pillar, and is fixed at any required height by means of a binding screw. The lamp should be placed in the position represented in the cut, in front of the magnet, its north pole being on the left.

201. When either of the junctions is in the flame, a current will flow from the German silver to the silver, ascending by the heated side of the arch and descending by the other. That face which is presented towards the north pole will possess north polarity, and the other face south polarity, according to the rule given in § 121. The influence of the magnet will now cause the arch to turn half way round, so as to present its southern face to the north pole. This movement brings the other

junction into the flame; the polarity of the arch is reversed, and it moves on as before.

202. If the lamp be placed in the corresponding position on the other side of the magnet, the direction of the current will be such that the southern face of the arch will be presented towards the north pole. In this position the arch tends to remain, returning to it when moved to either side; and consequently no revolution can be obtained. Care should be taken not to allow the junction to remain so long in the flame as to melt the hard solder.

203. **DOUBLE THERMO-ELECTRIC REVOLVING ARCH.**
In this instrument, two arches, *a* and *b*, fig. 87, are so

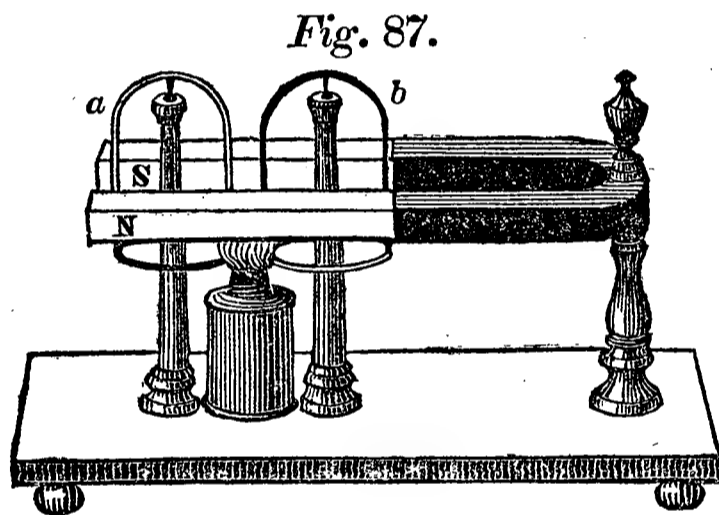

mounted as to revolve between the poles of a U magnet fixed in a horizontal position. The horizontal portion of the arch *a* is of German silver, and the upper part of silver; while in *b* the lower portion is of silver, and the upper part of German silver. A single lamp is so placed as to heat both arches; the current excited in each will ascend on its right side and descend on its left side, because the heat is applied to the right junction of *a* and to the left of *b*. Each of them now presents a north pole towards the north pole of the magnet, the currents circulating in the opposite direction to that of the hands of a watch. They will consequently both revolve, either in the same or in opposite directions. If the arches be transposed, so that *b* occupies the place of *a*, neither of them will move as long as the lamp is in the position represented in the cut.

204. ELECTRO-MAGNETISM AS A MOTIVE POWER.

The strong attractive force and the great velocity of motion exhibited by many of the small electro-magnetic instruments naturally suggested the application of this power to the purposes of the arts as a mechanical agent; and numerous experiments have been made with this view, but hitherto without success. Prof. Henry was the contriver of the first instrument whose motion depended upon magnetic attraction and repulsion: in his little machine, an electro-magnet, whose polarity was alternately reversed, was made to vibrate above the north poles of two straight steel magnets. He, however, made no attempt to apply this power to practical purposes. There are many obstacles of a purely mechanical character in the way of its employment; these, though important, are not perhaps insurmountable. But the most serious difficulties are those which seem to be inherent in the very nature of the power. The motion of the attracting poles of two electro-magnets towards each other, actually lessens the attractive force in proportion to the velocity with which they approach: the same thing occurs in the recession of mutually repelling poles. These phenomena are due to the influence of secondary electric currents produced by the motion, as will be explained hereafter, which flow against the battery current, and of course partially neutralize its magnetizing power. The secondary currents present a very formidable obstacle, as their opposing influence increases with the size of the machine in a rapid ratio. To their action and that of some other causes, is owing the fact, which was early discovered by those engaged

in these investigations, that the smallest machines possess by far the greatest proportional power.

III. BY THE INFLUENCE OF THE EARTH.

205. It has already been stated (§ 92) that a magnet freely suspended assumes a certain direction with respect to the earth. Now if an unmagnetic bar of iron or steel be placed in this position, that is, in the line of the dip, it will be found to acquire magnetism by induction from the earth. That extremity which is directed towards the north pole of the earth will have north polarity, and the other end south polarity.

EXP. 35.—Take a rod of soft iron, and holding it horizontally, bring it near to a magnetic needle. In this position the earth exerts very little inductive action upon it, and each end will attract indiscriminately either pole of the needle; showing that it possesses no perceptible magnetism except that induced in it by

Fig. 88.

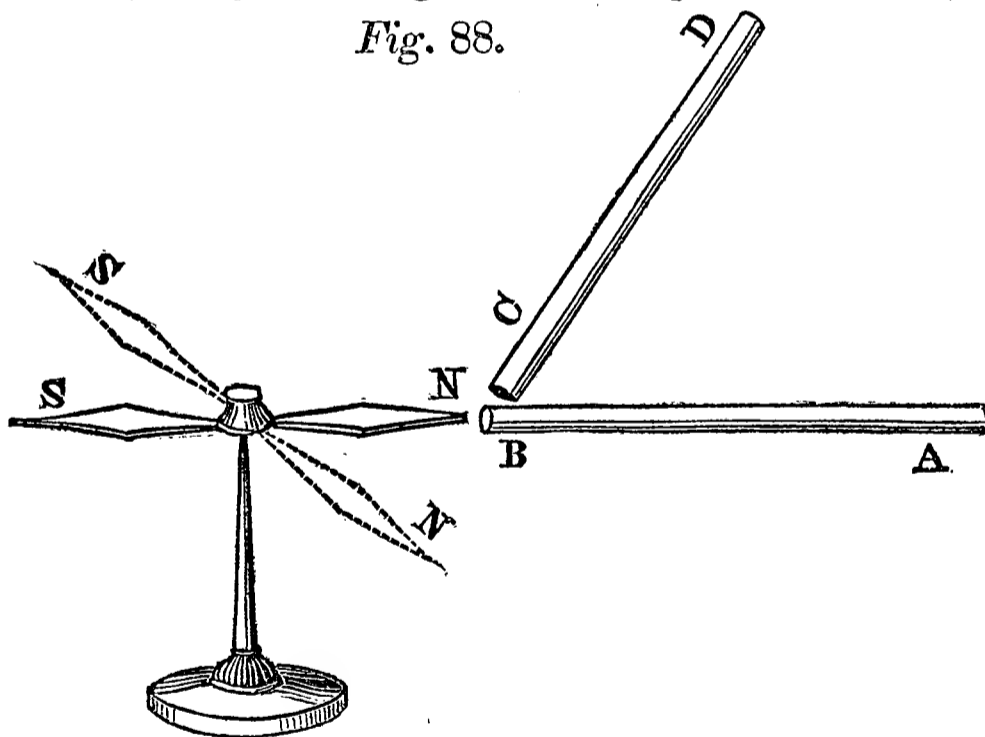

the needle, and which is the cause of its attraction. In fig. 88, A B represents an iron bar presented in this manner to the north pole of the needle. Now keeping the end B in the same place, raise the end A so as to bring the bar into the position C D. The north pole N will recede from C, as the bar is raised, as indicated by the dotted lines in the cut. The upper end of the bar D, on the contrary, will be found to attract N, and repel S. These

facts show that C D has become magnetic, C being the north pole. On reversing the bar, so as to bring the end D downwards, C will immediately become the south pole: thus the polarity of the rod may be changed at pleasure, the induced magnetism being only temporary. If the bar be brought very near to the pole of the needle, the inductive action of the earth will be overpowered by that of the needle, causing attraction to be exhibited in every position of the bar.

206. Except in places near to the equator, it is sufficient to hold the bar vertically, as the line of dip approaches to the perpendicular in high latitudes. In consequence of this inductive action of the earth, all large bars of iron standing in an upright position are more or less magnetic, their lower ends, in this hemisphere, being north poles. Where they have remained for a long time in this situation, the polarity does not disappear on changing their position.

207. The induction of magnetism by the earth is greatly facilitated by causing a motion among the particles of the bar, as by percussion or twisting.

EXP. 36.—Place a rod of iron or steel in the proper position, with its lower end near the north pole of a magnetic needle, but at a sufficient distance to avoid the repulsion of the pole by the bar in consequence of the magnetism induced in it under these

Fig. 89.

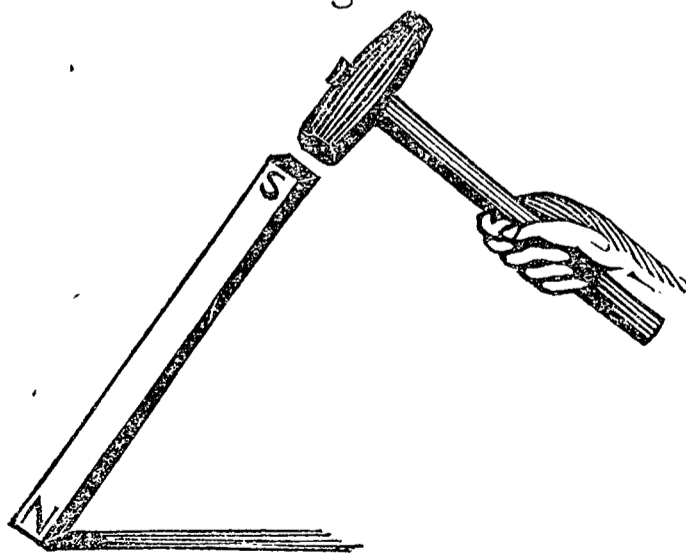

circumstances. Now strike the end of the bar with a hammer, as represented in fig. 89, and the pole will be instantly repelled. The polarity thus induced will not be reversed by merely inverting the rod, but the aid of percussion will also be required, in order to remove or reverse the magnetism.

EXP. 37.—Take a piece of iron wire, and placing it in a vertical position, twist it powerfully. It will then be found to have acquired the power to sustain iron filings at its extremities, and to

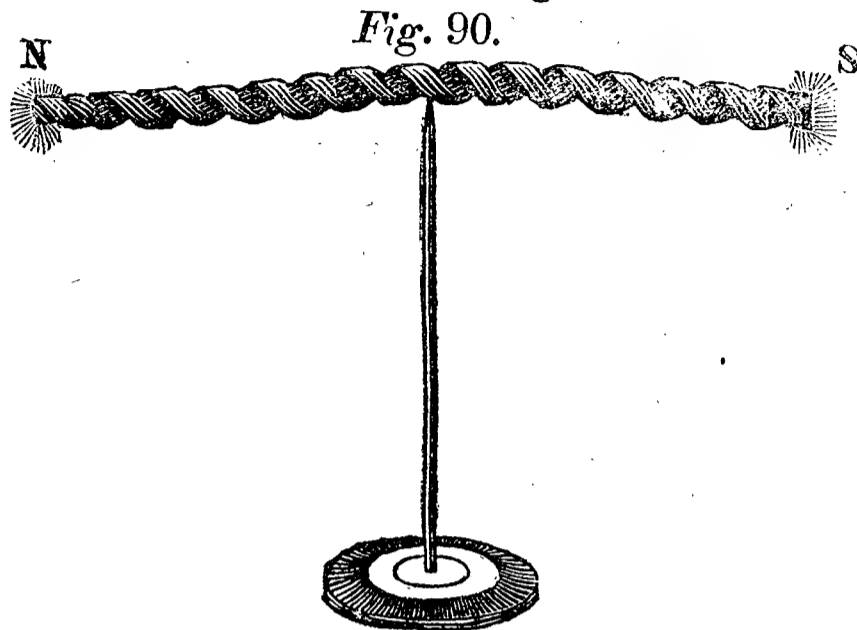

turn itself north and south, when balanced upon a pivot, as shown in fig. 90; the end which was downwards being its north pole.

208. The magnetism in these cases is not due directly to the percussion or twisting, which merely favors the action of the earth. A considerable degree of permanent magnetism may be communicated to a steel bar, by placing it vertically on a large mass of iron and striking its upper end repeatedly with a hammer: it will acquire much greater power if struck while resting on iron than on any other substance.

209. Percussion may be used to facilitate the removal of magnetism. Thus the polarity of a steel magnet may be lessened, or even entirely destroyed, by repeated blows of a hammer, while held horizontally east and west. This process is very convenient for removing slight degrees of magnetism from iron or steel bars. Merely falling upon the floor will often injure the power of a magnet considerably, in consequence of the vibration excited among the particles of the steel.

M A G N E T I S M .

III.

INDUCTION OF ELECTRICITY.

I. BY THE INFLUENCE OF A CURRENT OF ELECTRICITY.

210. That branch of the science of electricity which treats of the phenomena presented by it when at rest, is termed *Electro-statics*: the branch which relates to electricity in motion, is called *Electro-dynamics*. The phenomena which characterize the latter state are classified by Faraday as follows: "The effects of electricity in motion or electrical currents may be considered as 1st, Evolution of heat; 2d, Magnetism; 3d, Chemical decomposition; 4th, Physiological phenomena; 5th, Spark."

211. Many of the phenomena presented by electricity in motion being closely related to magnetism, are usually treated of in connection with that subject, as in the present case, rather than with electricity.

212. Before entering upon the particular subject of the present section, that is, the inductive action of currents, it will be advisable to occupy a few pages with a comparison of the phenomena exhibited by electricity in the two states of motion and rest, as induction is ex-

erted in them both ; it has already been intimated (§ 3) that the inductive action is different in the two cases.

213. In the case of electricity at rest, two bodies, charged either positively or negatively, repel each other ; while if one is charged with positive and the other with negative electricity, they exert a mutual attraction. Electrical currents, on the contrary, *attract* each other when flowing parallel in the same direction, and *repel* each other when flowing in opposite directions. The result is the same whether two different currents or two portions of one current be experimented upon.

214. The instrument represented in fig. 91 is designed to exhibit the attractions and repulsions of currents. Two wooden troughs for containing mercury are supported opposite to one another, each being divided into

Fig. 91.

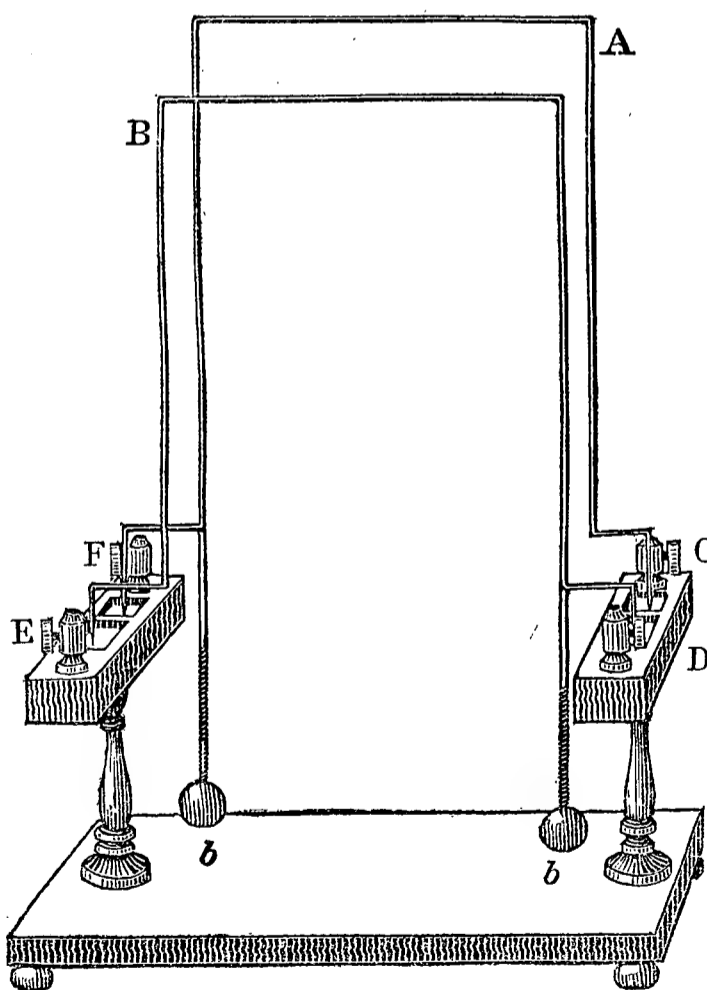

two oblong cells by a partition in the middle. Each of the four portions of mercury thus insulated, is connected by means of a wire projecting into the cell, with one of the binding screw cups fixed at the ends of the troughs. The points of two rectangular wires A and B rest in the opposite compartments of the troughs ; this mode of

support allows the wires to be placed nearer to or farther from each other at pleasure, still remaining parallel. These wires are balanced by two brass balls *b b*, attached to them below, which are capable of being raised or depressed by means of a screw cut in the wire; they may thus be so adjusted that the wires will be moved from their vertical position by a very slight force, their upper portions rocking towards or away from each other without requiring any motion of the points of support.

215. Cups C and E being united by a copper wire, connect cups D and F with the galvanic battery. The current will now traverse A and B in succession, flowing in the same direction in both, and they will be seen to incline towards each other. The motion is slight, but may be made considerable by breaking and renewing the circuit in correspondence with their oscillations. The same effect will be produced by uniting D with F, and connecting C and E with the battery. If a powerful current is employed, the wires will still attract each other when separated to a considerable distance, by moving the points which rest in the mercury to the farther ends of the cells; with a feeble battery, the wires should be placed near to one another.

216. Now unite C with D, and connect E and F with the battery. This will cause the current to flow in opposite directions in the two wires, and they will recede from each other; the extent of the motion may be increased as before by alternately opening and closing the circuit. Cups C and D may be connected with the battery with the same result, E and F being united by a wire.

217. The current, instead of traversing the wires in succession, may be divided into two portions by uniting C with D, and E with F, by two wires, and then connecting the battery either with C and F or D and E. In this case the two portions of the current will flow in the same direction in A and B, causing them to attract each other. By uniting C with E, and D with F, the currents in A and B will be in contrary directions, and the wires will exhibit a mutual repulsion. The movements produced by a divided current will be feebler than when it traverses the wires in succession, unless the battery employed is so powerful that one of the wires singly is not able to convey the whole of the electricity supplied by it.

218. These attractions and repulsions are sometimes called *magnetic*, the two currents when flowing side by side, acting upon each other like two magnets presented end to end. In fact, if two short pieces of iron wire be suspended end to end, and at right angles to the conducting wires, the magnetism induced in them by the currents (see Exp. 22) will cause them to exhibit similar attractions and repulsions to those of the wires themselves. It is, however, preferable to regard this peculiar action as a primary one; it being highly probable, though not as yet certain, that the polarity of even a steel magnet is due to electric currents circulating within its substance. The mutual actions of two magnets or of a magnet and a current would thus be secondary effects, depending upon the attractions and repulsions just described.

219. It is not essential that the current should tra-

verse metallic wires in order to produce these effects. Two streams of electricity flowing through a vacuum, or even through the air, will exhibit the phenomena in a very satisfactory manner.

EXP. 38.—The attraction of currents moving in the same direction may be shown by means of frictional electricity, in the following manner. Connect the inner coatings of two Leyden jars with either the positive or negative conductor of a common electric machine, their outer coatings being insulated sufficiently from each other to prevent the passage of a spark between them when the jars are discharged in the mode about to be described. With the exterior coating of each jar is connected a wire having one end free. These ends are left free for the purpose of being placed on a card over which the charge is to be passed. The common enamelled cards should be used, as they receive a dark colored and permanent mark from the passage of the spark over their surface. A third wire, attached to the discharging rod, is also to rest on the card, at such a distance from the two other wires that the sparks from the jars may be able to pass. The ends of the wires proceeding from the outside of the jars should be placed a quarter or a half of an inch apart, and nearer to one another than to the third wire, which is to be equally distant from both, so that if two straight lines were drawn from it to them they would form the letter V. The jars being charged (during which process the exterior coatings should, of course, be uninsulated), arrange the points as directed, and bring up the ball of the discharging rod to the conductor. The inner coatings being connected, and the outer ones insulated, the current is obliged to divide into two portions as it proceeds from the point attached to the discharger to those in connection with the outside of the jars. The two sparks will thus pass simultaneously over the surface of the card, and were they unaffected by each other, would leave a mark in the shape of the letter V. It will be found, on the contrary, that the tracks left on the card will be more or less in the form of the letter Y, the two currents coalescing in their passage over its surface. The result will be the same whether the jars be charged positively or negatively on the inside.

If the wire connected with the discharger be placed under the card while the others are on the upper side, it will be perforated in one or more places by the passage of the electricity.

EXP. 39.—The experiment may be varied, by connecting with the discharging rod a wire whose ends may both rest on the card at the same distance from each other as that between the two wires attached to the exterior coatings of the jars. The two sets of points being arranged parallel to each other, and their distances properly adjusted, the two currents will remain separate during the whole of their passage over the card; and it will be seen by the marks which they leave, that instead of proceeding in straight and parallel lines, they form curves whose convexity is turned towards each other. The curvature of the lines is greater in proportion to their proximity: if the points are placed too near together, both currents will flow in one track, not separating until they reach one of the wires connected with the outside of the jars. The resistance of the air and other causes often occasion a stream of electricity to follow a very crooked path in passing over a card. Hence the lines traced by the two currents in these experiments may be very irregular, though the tendency to converge is perfectly evident.

220. ELECTRO-DYNAMIC REVOLVING RING. The mutually attractive and repulsive action of currents may

Fig. 92.

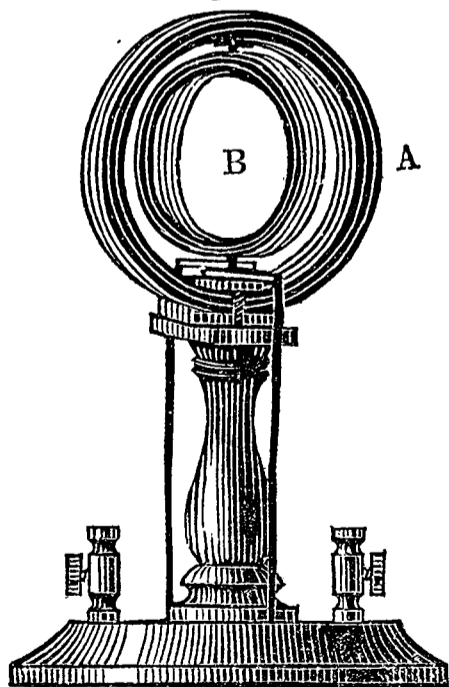

be made to produce a revolution analogous to some of those strictly called electro-magnetic; as in the instrument represented in fig. 92, which consists of a coil of insulated wire B fitted to rotate on a vertical axis within a larger one A, mounted on a brass pillar. The inner coil has a pole-changer fixed to its axis of motion for the purpose of reversing the current twice in each revolution.

The current may traverse the two coils in succession, or be divided between them, but its direction must be changed only in **B**.

221. The coil **B** being placed at right angles to **A**, and the cups on the stand connected with the galvanic battery, the faces of each coil immediately exhibit north and south polarity, like those of De la Rive's Ring (§ 130); and **B** is obliged to make a quarter of a revolution in order to bring its north pole within the north pole of **A**, the two coils corresponding in direction. As soon as **B** reaches this position, the current is reversed by means of the pole-changer, and its south pole now being within the north pole of **A**, it continues to move on in the same direction. The motions in this case depend upon the same principle as those of the wires in the instrument represented in fig. 91; but it is more convenient to refer them to the polarity exhibited by a current flowing in a circle, as was done in describing Page's Revolving Ring.

222. It is, however, easy to explain the revolution with direct reference to the mutual action of the currents. As these circulate in the same direction in every convolution of each coil, they may be regarded as two single circular currents. Now suppose the current in **A** to be ascending by the left side and descending by the right side of this coil. If **B** be placed at right angles to **A**, with its current ascending by the side towards the spectator, this side will be attracted by the left side of **A** and repelled by the right. The farther side of **B**, on the contrary, will be repelled by the left side of **A**, and attracted by the other. These forces will conspire

in bringing B into the same direction with A ; when the current being reversed, each side of B is repelled by the corresponding one of A, and it is obliged to continue its motion, revolving from left to right.

223. Portions of the same or of different currents moving in a continuous line *repel* one another. Hence a short wire whose ends rest in two mercury cups interposed in the circuit of a galvanic battery, consisting of a few pairs of very large plates, and in vigorous action, will be thrown out of the mercury at the moment of completing the circuit. The repulsion is here exerted between the immediately succeeding portions of the current, as it passes from the mercury to the wire, and also as it leaves the wire to enter the other portion of mercury ; the forces thus acting at each end of the wire will conspire in raising it out of the cups.

224. An electrified body attracts light substances in its neighborhood, having previously induced in their nearest ends the opposite electricity to its own ; and on their approach communicates to them a part of its charge, when, if insulated, they are instantly repelled by it. A wire conveying a current exerts no such influence upon light bodies, although placed in the immediate vicinity.

225. We now proceed to consider the inductive action of currents, taking first in order those phenomena which are referred to the induction of a current on itself. When the poles of a small galvanic battery, consisting of a single pair of plates, are connected by a copper wire of a few inches in length, no spark is perceived when the connection is either formed or broken, or at most a

very faint spark at the moment of opening the circuit; but if a wire forty or fifty feet long be employed, though no spark is seen when contact is made, a bright one appears whenever the connection is broken by lifting one end of the wire out of the cup in which it rests. By coiling the wire into a helix, the spark becomes more vivid; and a still greater effect is produced by making use of the wire surrounding an electro-magnet.

226. The most advantageous length for producing the spark depends upon the diameter of the wire, and also upon the number of pairs in the battery and the size of its plates; the larger the wire, the greater is the length required to produce the maximum result. With a single battery whose zinc plate exposes about a square foot of surface to the solution, and a wire of one sixteenth of an inch in diameter, a length of sixty or seventy feet will probably give the brightest spark, though much will depend upon the degree of vigor with which the battery is acting. This peculiar action of a long conductor, either extended, or coiled into a helix, in increasing the intensity of the current from a single galvanic pair, at the moment when it ceases to flow, was discovered by Prof. Henry (now of New Jersey College) in 1831, while at the Albany Academy.

227. With a wire two or three hundred feet long, a slight shock may be felt at the moment of opening the circuit, if its ends near their connections with the poles are grasped with moistened hands; with a shorter wire, shocks may be obtained through the tongue; their intensity increases until a length of five or six hundred feet is attained. A single pair of plates can, of course,

give no shocks directly: the peculiar and continuous sensation excited in the tongue when the current from a single pair is made to pass through it, is not called a shock. With a battery of smaller size or consisting of a number of pairs, greater lengths may be used with advantage both for the spark and shock. The maximum effects of a small battery are, as might be expected, much inferior to those of a large one. If the requisite lengths of wire are exceeded, the effects are lessened.

228. The brilliancy of the spark is much increased by employing a ribbon of sheet copper coiled into a flat spiral, instead of a wire. A description and figure of this instrument has been given in § 123. The spiral being connected with the battery, a brilliant spark will be seen, accompanied by a pretty loud snap, whenever contact is broken; and if two metallic handles be attached by wires to the cups of the coil, and held in the hands, a slight shock will be felt; if the battery is in feeble action, the shocks may be perceptible only when passed through the tongue. No shocks can be obtained by interposing the body in the direct circuit with the coil, so that the battery current may traverse them in succession; as the electricity supplied by a single pair of plates is of too low intensity to be transmitted, to any considerable extent, by so poor a conductor as the human body. Prof. Henry was the first to employ coils of metallic ribbon for obtaining sparks and shocks from a single pair of plates.

229. For the purpose of rapidly breaking the circuit, the *Contact Breaker*, represented in fig. 93, is very convenient. It consists of a bent copper wire W W,

which by means of clock-work set in motion by a spring, is made to vibrate rapidly, dipping its ends alternately into the glass cups G G, intended to contain mercury. The spring is wound up by turning the milled head A.

Fig. 93.

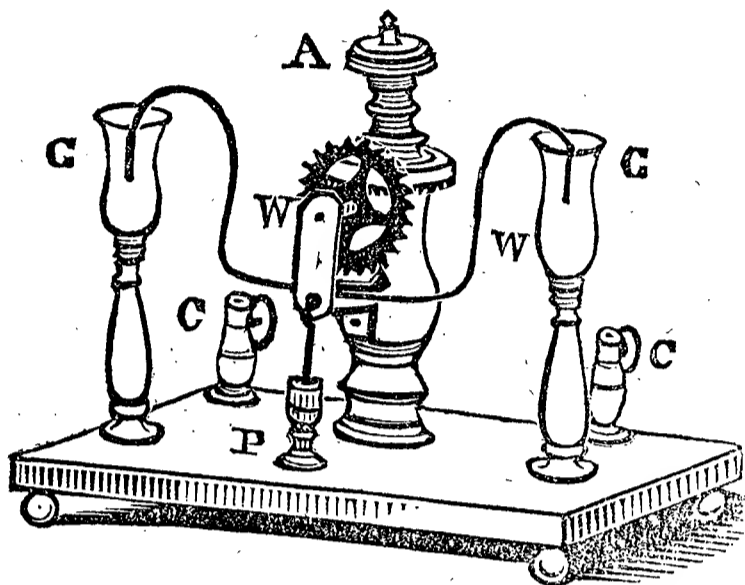

The glass cups are open at the bottom to allow the mercury to come in contact with the brass pillars into which they are cemented. These pillars are both connected with one of the binding screw cups C

C; the other cup communicates with a brass mercury cup P, into which dips a short wire connected with the vibrating wire. Sufficient mercury must be put into the cup P, to keep the end of the vertical wire covered, and enough into the glass cups to allow one end of W W to leave the mercury in its cup a little before the other end dips into its portion.

230. The Contact Breaker may be advantageously used in connection with many of the instruments for affording sparks and shocks, which will be described under the following head. The current must be transmitted through the two instruments in succession, by connecting one of the cups C C with one pole of the battery, and the other cup with one of those attached to the spiral or other piece of apparatus, the remaining cup of which is to communicate with the other pole of the battery. It is better to break the circuit mechan-

ically in this way, than by means of any interrupting apparatus worked by the battery itself, as a considerable part of the power of the current is then expended in giving motion to the interruptor.

231. On making connection in this manner with a flat spiral (fig. 49), and turning the milled head A to put the vibrating wire in motion, a brilliant spark will be seen at each rupture of contact, accompanied by a loud snap, and producing considerable combustion of the mercury. With a battery consisting of a few pairs of plates of large size, such as Dr. Hare's Calorimotor, the size of the spark will be greatly increased and the snap become as loud as the report of a Leyden jar. The shock will also be pretty strong, and may be increased by covering the mercury in the glass cups with a stratum of oil. A shock may be obtained, especially when oil is used, on closing the circuit as well as on opening it, though inferior to that given in the latter case; a faint spark is also sometimes seen when the wire dips into the mercury.

232. The requisite length and thickness of the copper ribbon to give a maximum result depend upon the size of the battery employed. With spirals of considerable length, even if the copper be pretty thick, two or three pairs of plates are better than one, as the metal opposes some resistance to the passage of a current of low intensity. A ribbon spiral of moderate length interposed in the circuit of a compound battery, consisting of a considerable number of small pairs, produces scarcely any peculiar effect: while a coil containing three or four thousand feet of fine insulated wire will give an intense

shock, though not a very brilliant spark, under the same circumstances. The higher the intensity of the electricity and the smaller its quantity, the less is the size requisite in the metallic conductor and the greater may be its length.

233. The sparks and shocks given by long wires and by spirals are due to *secondary currents* induced in the metallic conductor at the moment of opening and closing the circuit; their intensity being higher than that of the current which produces them. The phenomena belong to the same class as those presented by the secondaries induced in another conductor placed in the vicinity of the one which is conveying the battery current.

234. The secondary currents just referred to may be obtained by placing a second spiral of copper ribbon upon the one through which the battery current is transmitted. If the edges of the copper strips are exposed, some insulating substance, such as glass or paper, must be interposed between the two spirals.

EXP. 40.—Two wires being connected with the cups belonging to the upper spiral, rub their ends together while the circuit through the lower one is rapidly broken. Sparks will be seen, and slight shocks may be felt through the fingers or by placing the wires in the mouth. When the ends of the wires are joined, the sparks and snaps given by the spiral connected with the battery are considerably diminished and no shocks can be obtained from it.

EXP. 41.—Connect the cups of the upper coil with a delicate galvanometer such as that represented in fig. 13. Whenever the battery circuit is completed through the lower spiral, the magnetic needle will be deflected to a considerable extent, but will immediately return to the meridian, indicating the flow of a momentary current through the wire of the galvanometer. On opening the circuit a similar transient deflection will occur in

the opposite direction. No deflection occurs while the battery current is flowing steadily. Care should be taken that the galvanometer is placed at such a distance from the lower spiral, that its needle may be unaffected by it.

EXP. 42.—A sewing needle will be magnetized if placed within a wire helix of small internal diameter connected with the upper spiral. The polarity produced by the current which attends the completion of the circuit will be the reverse of that communicated by the one attending its rupture. If both currents are allowed to act on the needle, it will acquire little or no magnetism.

235. For the purpose of determining the direction of induced currents, the *Magnetizing Helix* represented in fig. 94 may be employed. Its construction is similar to that of the helix described in § 120: it should, however,

Fig. 94.

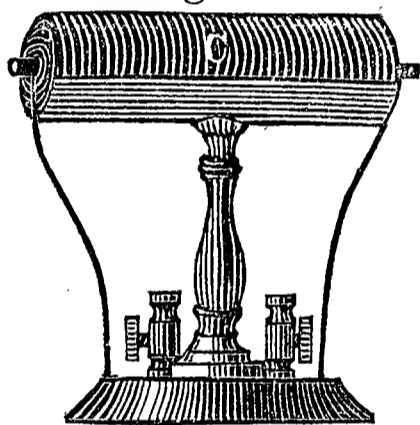

consist of a single length of wire, but wound so as to form six or eight layers of coils, to enable it to be used for examining currents of considerable intensity. Its power will be greater if its internal diameter is very small. In the cut, the helix C is mounted upon a stand, with a small piece of steel wire within it.

236. The momentary waves of electricity excited by electro-dynamic induction in a conductor conveying a current, or in a neighboring one, are termed *secondary currents*, the battery current itself being called in this connection the *primary* one. The wave which accompanies the closing of the circuit is termed the *initial* secondary, and flows in the opposite direction to that of the current which induces it. The other, which follows the opening of the circuit, is called the *terminal* second-

ary, and flows in the same direction as the inducing current. These currents were discovered by Prof. Faraday, in 1831.

237. In fig. 95 a coil of fine insulated wire *W* is represented placed over a ribbon spiral *A*, which is connected by one cup with the cup *C* attached to the

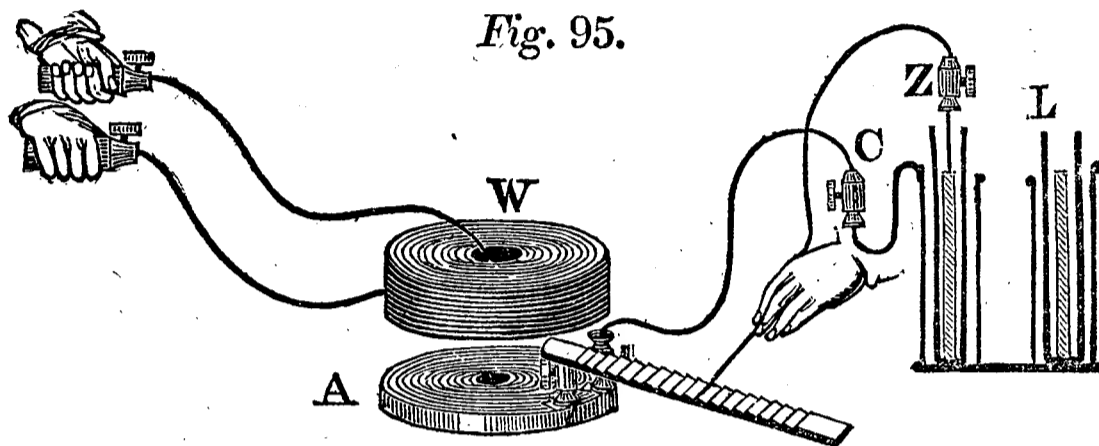

copper plate of a *sustaining battery*. A wire from the cup *Z*, belonging to the zinc plate, is drawn over a steel rasp resting on the other cup of the flat spiral, for the purpose of breaking the circuit rapidly.

238. The ends of the wire coil *W* being fixed in the binding screw cups of the metallic handles, powerful shocks will be felt when these are grasped in the hands and the wire connected with *Z* drawn over the rasp. In order to obtain the *initial* and *terminal* shocks separately, the circuit should be broken, not by means of the rasp, but by a cup containing mercury into which one of the battery wires can be dipped at pleasure. The mercury should, of course, be connected by a wire with one of the cups attached to the ribbon spiral.

239. When a battery of a single pair of plates is employed, the initial secondary is much inferior in intensity to the terminal, and consequently gives a feebler shock. Prof. Henry discovered that the intensity of the terminal

current is very little increased by adding to the number of pairs; the slight increase which occurs is due to the greater quantity of electricity transmitted by the ribbon spiral, when the intensity of the battery current is increased. With the initial secondary it is different; every additional pair was found to raise its intensity, so that with about ten pairs it equalled, in this respect, the terminal, and with a larger number excelled it. The initial shock may also be increased, though not in any great degree, by employing a shorter ribbon spiral, as for instance, one fifteen or twenty feet in length, with a single pair of plates. In *quantity*, as indicated by the galvanometer, the two secondaries are equal; those of the wire coil being inferior in this respect to the currents afforded by a ribbon coil.

240. The coil represented at W contains three thousand feet of copper wire, about one-fiftieth of an inch in diameter, wound with thread; the layers are firmly cemented together by shellac, careful insulation being requisite in consequence of the length of the wire and the high intensity of the current obtained. Where a small battery is used, this length of wire is unnecessary, as the shock given by it is scarcely greater than that from a coil of one thousand feet; with a larger battery the longer one will be much superior. A sewing needle may be magnetized by the currents from a long wire coil, as well as by those from a ribbon spiral (see Exp. 42): if the wire is fine and very long this effect will be diminished.

241. The *sustaining battery* shown in section in fig. 95 is of similar construction to the cylindrical battery

described in § 20, except that the zinc plate is placed within a double cylinder of leather L, closed at the bottom; the space between this and the copper cylinder on each side is alone occupied by the solution of sulphate of copper, which may be a saturated one; while within the leather case is a rather weak solution of Glauber's salt (sulphate of soda) or of table salt. The leather should be free from oil, or the power of the battery will be greatly reduced. Other porous or membranous substances, such as thick brown paper, or bladder, will answer the same purpose as leather, in preventing the ready admixture of the solutions, and allowing a free passage to the electrical current. When the partition is sufficiently thin or permeable, the battery is as powerful as if charged in the usual mode with a solution of blue vitriol.

242. The action within the battery is as follows: the zinc is oxidized as usual, at the expense of the water of the solution which surrounds it, while the hydrogen, instead of being given off at the surface of the negative plate, as in most batteries, decomposes the sulphate of copper, forming water with the oxygen of the oxide of copper, and liberating the sulphuric acid, which passes through the porous partition into the other cell. A gradual and steady supply of acid is thus furnished to dissolve the constantly forming oxide of zinc.

243. This form of battery will maintain a nearly unvarying power for several days in succession, if the solution of sulphate of copper is kept saturated by occasionally adding a little of the pulverized salt and stirring the liquid to make it of uniform strength. With weaker

solutions, or a less permeable partition, an action of sufficient energy for many purposes may be sustained for a week or more; and when it declines, may be renewed by cleaning the zinc plate and removing any loose deposit from the cells. This constancy of action renders the battery of great value in the electrotype process, which will be described hereafter. The deposition of metallic copper on the negative plate is the principal inconvenience attending it: this deposit sometimes adheres so firmly as to be difficult of removal, which, however, is only necessary when it interferes mechanically with the working of the battery. The adhesion may be partially prevented by slightly oiling or greasing the copper cylinders previous to the introduction of the solutions.

244. Instead of flat coils, long helices of insulated wire may be employed for obtaining the secondary currents, though with less effect when not aided by magneto-electric induction. Several of the magneto-electric instruments which will be described under the next head may be used for this purpose, the iron bar or bundle of wires being withdrawn from the helices. A description of one of them (the Double Helix and Electrotome) may properly be introduced in this connection.

245. DOUBLE HELIX AND ELECTROTOME. In this instrument, represented in fig. 96, the double helix *a a* is confined to the base-board by three brass bands. The inner helix is composed of several strands of large insulated copper wire. The similar ends of these strands at one extremity of the helix are connected with the binding screw cup *c*. Their other ends are soldered

to the middle brass band, which is surmounted by a brass mercury cup *e*. Into this cup descends a copper wire attached to the wire *w w*, which by means of clock-work set in motion by a concealed spring, is made to

Fig. 96.

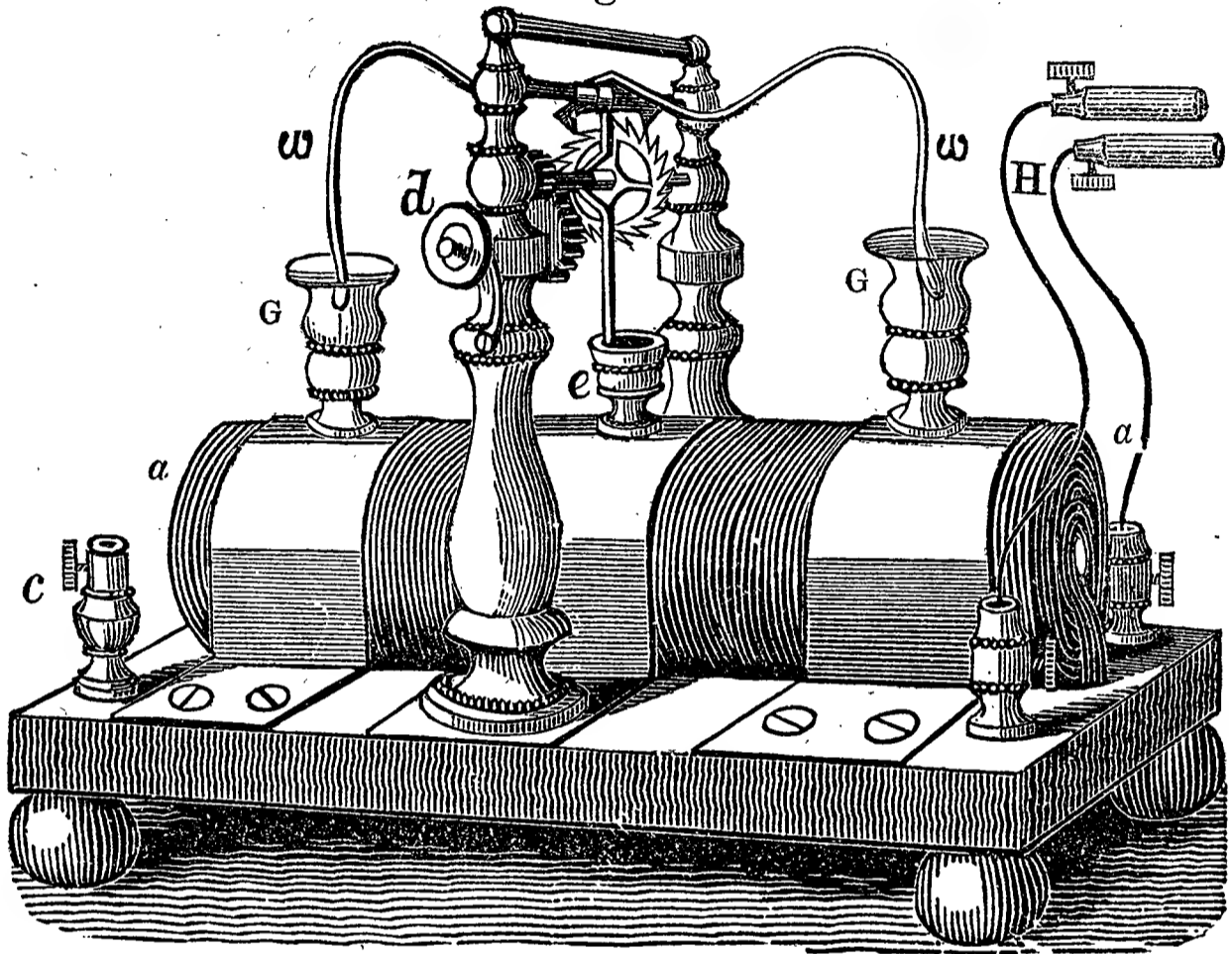

dip its ends alternately into the glass cups *G G* for containing mercury. The cups being open at the bottom, the mercury is brought in connection with the outer brass bands, upon which they are fixed. Both these bands are connected with a binding screw cup *c'*, corresponding to *c*, but not seen in the cut. A second helix, consisting of about two thousand feet of fine insulated wire, encloses the one just described, but is insulated from it: its ends are soldered to the binding screw cups to which the handles, seen at *H*, are attached.

246. The cups *c* and *c'* being connected with the galvanic battery, the current will pass through the inner

helix whenever either end of the wire *w w* dips into the mercury; which should stand at such a height in the cups that both extremities of the wire shall not be immersed at the same time. By turning the milled head *d* the spring is wound up and the wire is made to vibrate rapidly. When either end leaves the mercury, the flow of the current is interrupted, and a bright spark is seen in the cup. If the handles be grasped with moistened hands, strong shocks will be felt whenever the circuit is broken. Introduce into the helix a brass tube, and the spark becomes small and the shock feeble; if the tube be sawed open in the direction of its length, it no longer produces these effects.

247. When an iron bar or a bundle of soft iron wires is introduced into the helix, the brass tube being withdrawn, the brilliancy of the sparks and the intensity of the shocks are greatly increased, the instrument being under these circumstances one of the most powerful belonging to the department of magneto-electricity.

248. We have seen that a battery current of considerable quantity and low intensity can induce either a quantity or an intensity current. By substituting for the ribbon spiral through which the battery current is transmitted, a coil consisting of one thousand feet or more of fine insulated wire, and connected with a battery of a number of pairs, it will be found that an intensity current is able to induce secondaries of intensity in a wire coil, and of quantity in a ribbon coil.

249. The shocks obtained when the body is introduced into the circuit of a voltaic battery of a considerable number of pairs, without a coil, appear to be due

to secondary currents induced in the battery itself. During the uninterrupted circulation of the galvanic current through the body, little or no effect is perceived; but at the moment of either opening or closing the circuit, a shock is experienced. When the series is very extensive, a dull pain is felt during the continuance of contact. The primary current has sufficient intensity to traverse the body, though not to give shocks, and doubtless induces *initial* and *terminal* secondaries when it commences and ceases to flow.

250. A flat spiral being in connection with the battery, let a fine wire coil be placed at a little distance above it; shocks may now be obtained from the wire, but their intensity diminishes in a rapid ratio as the distance between the coils is increased. With the arrangement represented in fig. 95, shocks through the tongue are readily obtained when the wire coil is a foot or two above the other; and the distance may be still farther increased by using a longer ribbon coil or a more powerful battery. This furnishes a convenient mode of regulating the intensity of the shock at pleasure: the same effect is produced when one coil lies upon the other, by sliding the wire coil from its central position more or less beyond the edge of the flat spiral. The shocks are in any case much increased by wetting the hands, especially with salt water.

251. The intensity of the shock also diminishes rapidly as the wire coil is raised from a horizontal position into an inclined one; and when it reaches a vertical position, its edge resting on the ribbon coil, they are no longer felt. Similar phenomena are presented when

the flat spiral has a sufficiently large central opening to allow the wire coil to pass within it; no shocks being obtained when their axes are at right angles to each other. If the diameter of the wire coil be considerably less than that of the ring, and it be placed in a horizontal position within it, the shocks will be somewhat stronger when it is near the side than when in the centre.

252. The interposition of any good conductor of electricity between the fine wire coil and the one connected with the battery will nearly neutralize the shocks.

Exp. 43.—The coils being arranged as in fig. 95, interpose a slip of wood or a plate of glass between A and W, and the shock will be the same as if air only intervened. This will be the case with any non-conductor of electricity. Now interpose a plate of metal, for instance, lead or zinc, one-tenth of an inch thick and as broad as the coils. The shock will be so much reduced as to be scarcely perceptible. The magnetizing power of the current is also lessened, in respect to hard steel, so that a sewing needle placed within a helix, as in Exp. 42, will be but feebly charged. A certain thickness of metal is required to produce these effects, as several sheets of tinfoil may be interposed without diminishing the shocks in any appreciable degree.

253. The interposition of a metallic plate does not prevent the occurrence of the secondary currents, but merely causes their intensity to be greatly reduced. That the quantity of the current is not affected may be shown by connecting the ends of the upper coil, especially if it be a ribbon coil instead of a wire one, with a galvanometer; when the deflections will be the same whether the plate is interposed or not, provided the distance between the two coils is not altered; except the plate is of iron, when they are somewhat diminished.

If a slip be cut out of the interposed plate in the direction of a radius, the cut extending to the centre, it no longer lessens the shocks.

Exp. 44.—Instead of a metallic plate, interpose a flat spiral between the battery coil and the wire one. No diminution of the shocks will be perceived. Now connect the cups of the interposed coil by a wire, and the intensity of the shocks will be even more reduced than in the last experiment. Whenever the shocks are diminished, the brilliancy of the sparks given by the battery spiral will also be lessened to some extent.

254. Secondary currents may also be obtained, without breaking the primary circuit, by altering the quantity of the battery current or the distance between the coils, as in the following experiments.

Exp. 45.—Connect a ribbon coil with the battery, and place a second spiral of the same kind upon it, with its cups in connection with a galvanometer. While the current is flowing steadily through the lower spiral, no secondary will be excited, and the needle of the galvanometer will be unaffected. Now lift the zinc plate of the battery partly out of the liquid. The moment the plate begins to be raised, the needle moves in the same direction as if the circuit were broken; the deflection, however, is not momentary as in that case, but continues during the movement of the plate. Then, without taking the zinc out of the solution, which would break the circuit, depress it again. The galvanometer will now indicate a current in the opposite direction to the former one.

Exp. 46.—Similar currents are produced by raising the upper coil from the lower one, through which the galvanic current is steadily flowing. As the coil recedes, a secondary flows through it in the same direction as that of the battery current in the other spiral; as it again approaches, a current in the reverse direction is induced. Instead of raising the upper spiral, it may be moved laterally from its central position on the lower one, with the same result.

255. These currents produce a greater effect upon the galvanometer than those excited by closing and opening the circuit, as they are not momentary, but last as long as the motion continues. The more rapid the movement of the zinc plate or of the spiral, the more powerful are the secondary currents, as they depend upon the suddenness of the change, in the quantity of the primary current in one case, and in the distance between the coils in the other. They are, however, of low intensity, and are unable to afford shocks. The interposition of metallic plates or coils produces no effect upon them.

256. The neutralizing action described in § 252 and 253 is due to a secondary current excited in the interposed metallic plate or spiral, which itself induces a *tertiary* current in the wire coil, flowing in the opposite direction to the secondary induced in it by the battery current, and therefore retarding its development. A tertiary current is also induced in the battery coil, which occasions the reduction in the spark and shock noticed in Exp. 40 and 44. When the interposed plate of metal is divided to its centre, no secondary is induced in it, and it exerts no neutralizing action; the same is the case with the ribbon spiral in Exp. 44, when its cups are disconnected. Similar phenomena are produced by the introduction of a metallic tube into a wire helix, as described in § 246.

257. This *tertiary* current can be separated from the secondary, and obtained by itself, in the following manner.

EXP. 47.—A ribbon coil B, fig. 97, being laid upon the coil A, through which the battery current is transmitted, connect its

cups with those of a third spiral C, of the same kind, removed to a little distance, so as to be beyond the influence of the current in

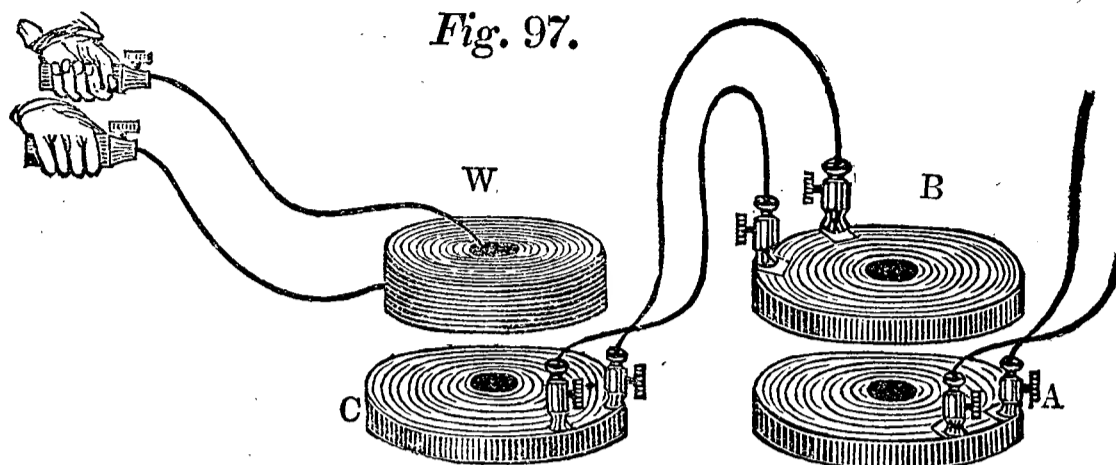

A. The secondary current induced in B will now flow through C, and if a fine wire coil W is laid on C, strong shocks may be obtained. If W be raised up, the shocks will still be felt when it is at a considerable height above C.

EXP. 48.—Place a fourth ribbon coil on C instead of the wire coil, and a quantity current will be obtained, capable of affecting the galvanometer slightly, and of magnetizing a sewing needle placed in a helix of small internal diameter, such as that represented in fig. 94.

EXP. 49.—Substitute for the flat spirals B and C in fig. 97 two fine wire coils. A secondary intensity current will now be obtained, which will induce a tertiary of intensity in a third wire coil laid on the second, enabling it to afford strong shocks; and a tertiary of quantity in a ribbon coil.

258. If the second spiral B is alone replaced by a wire coil, little or no shock can be obtained from W, the quantity of the secondary current furnished by the wire coil not being sufficient for the production of a powerful tertiary, unless it is passed through a conductor of many convolutions. So, on the other hand, if a fine wire coil be substituted for C only, no tertiary is induced by it, or at most a feeble one, the secondary current from B not having sufficient intensity to enable it to overcome the resistance of the long wire. The

tertiary current, like the secondary, can be induced at a distance; and has its intensity greatly reduced by the interposition of metal between the flat spiral C and the wire coil.

259. The tertiary currents may be conveniently obtained by causing the secondary from a ribbon spiral to flow through the inner helix of the instrument represented in fig. 96 or of almost any of the magneto-electric instruments to be described under the next head. Thus if the wires attached to B, in fig. 97, are fixed in the cups *c* and *c'* of the Double Helix and Electrotome, strong shocks may be obtained from the tertiary current induced in the fine wire helix. The circuit through the inner coil should not be broken by the electrotome, as the only interruption wanted is that in the battery current. The shocks will be increased by placing a bundle of iron wires within the helix, as the inductive action of the current will then be assisted by that of the electromagnet.

260. Tertiary currents, like secondaries, are induced both when the primary circuit is opened and when it is closed. The *initial* and *terminal* tertiaries both flow in the opposite directions to the corresponding secondaries. In fact, each secondary must produce two tertiaries, one when it commences, and another when it ceases to flow: but in consequence of the exceedingly short duration of the secondary itself, they cannot be separated as the initial and terminal secondaries can; and the current which is obtained, whether initial or terminal, is only the difference between the two. This accounts for the slight effect it produces upon the galvanometer, while

capable of affording strong shocks. The two parts may differ very much in intensity, but being equal in quantity would not affect the galvanometer, did they occur precisely at the same instant: the needle, however, is first deflected by the momentary wave induced by the commencement of the secondary, and as soon as it has moved a degree or two is arrested by the opposite wave due to its cessation.

261. The effects of the interpositions described in § 252 and 253, may now be more clearly explained. The secondary induced in the interposed conductor, on opening the primary circuit, for instance, itself induces a tertiary in the wire coil at the instant of its commencement, which flows against the secondary induced in it by the battery current. When the secondary in the interposed body ceases, another tertiary is excited in the wire coil flowing in the same direction as the secondary. The total amount of the current will not be altered, since the same quantity is added at its ending as was subtracted at its beginning; but its intensity will be greatly reduced, probably in consequence of the diminished rapidity of its development.

262. CURRENTS OF HIGHER ORDERS. It has been shown that a secondary current, though only momentary in its duration, can induce a tertiary of considerable energy. It might therefore be expected that the tertiary would produce a current of the fourth order; this another, and so on; and such is found to be the case. It is only necessary to remove the tertiary out of the influence of the secondary in the same manner as the secondary is removed from that of the primary (see

Exp. 47) in order to obtain a current of the *fourth order*. The currents of the third, fourth and fifth orders were first obtained by Prof. Henry, and two other orders have been since added. These currents progressively diminish in energy, but the phenomena presented by them are similar to those of the tertiary. With a larger number of coils and a powerful battery, the series might doubtless be extended much farther.

263. In the following table the directions of the currents produced both at the beginning and ending of the battery current are given, those which flow in the same direction as the primary being indicated by the sign +, and those in the opposite direction by the sign —.

	At the beginning.	At the ending.
Primary current,	+	+
Secondary current,	—	+
Tertiary current,	+	—
Current of the fourth order,....	—	+
Current of the fifth order,	+	—
Current of the sixth order,	—	+
Current of the seventh order, ..	+	—

If the induction at the ending of the battery current be regarded as opposite to that at the beginning, the second column may commence with minus instead of plus, and the second series will then alternate like the first.

264. Induced currents of the different orders may be obtained from frictional electricity, though in consequence of its high intensity the conductors require better insulation than is necessary when they are used with the galvanic battery. The flat spirals and wire coils may, however, be employed, if their layers are carefully insulated by means of shellac, or if covered with silk instead of cotton.

Exp. 50.—Place a fine wire coil over a ribbon spiral, with a plate of glass interposed; a secondary shock may now be obtained from the wire when the charge of a Leyden jar is passed through the spiral. A still better mode is to employ a second wire coil, instead of the flat spiral; if the ends of one coil be held in the hands, a strong shock will be felt at the moment of discharging the jar through the other. The secondary current flows in the same direction as the one which induces it; as may be shown by passing it through the helix described in § 235, when it will magnetize a sewing needle placed within it.

II. BY THE INFLUENCE OF A MAGNET.

265. Currents of electricity may be excited in metallic wires by means of magnetic changes taking place in their vicinity. This is in fact the converse of the principle explained in chap. II, sect. 2. It was there shown that a current of electricity passing in the vicinity of a bar of iron or steel produces a magnetic change in that bar. The branch of science which treats of the development of electricity in this way is called *Magneto-Electricity*.

266. There are several modes in which these magnetic changes may be produced in the vicinity of the wire in which the current of electricity is to be excited. The movement of a magnet near a wire, or of a wire near a magnet, is one method. The approach of a magnet to a bar of soft iron surrounded with wire, or in general, a change in the relative position of the magnet and the bar, is a second. The passage of a galvanic current round an iron bar wound with wire is a third: in this case an induced current may be obtained either from the wire conveying the primary current, or from a

second wire also surrounding the iron; but the current excited by the influence of the magnetized bar cannot be separated from that which is the result of electrodynamic induction, at least with the usual arrangement of the wires.

267. If the cups of the helix on stand, described in § 120, be connected with a delicate galvanometer, and a bar magnet be introduced into the helix, as in fig. 98, the needle will be deflected while the magnet is passing

Fig. 98.

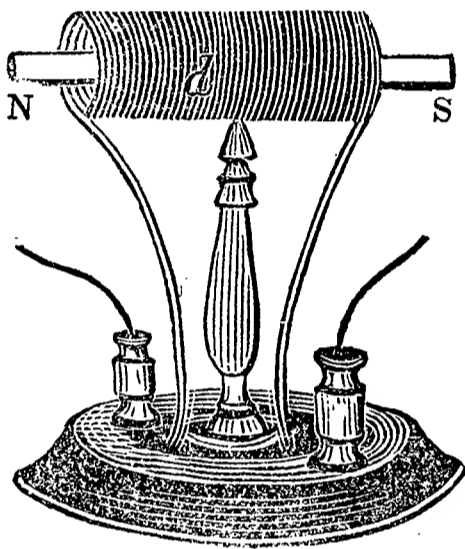

in, but will return to its former position as soon as the magnet is at rest within the coil. On drawing the magnet out, the needle will be deflected in the opposite direction. By moving the magnet in and out so as to keep time with the oscillations of the needle, they will be greatly increased. Reversing the direction of the magnet so as to cause it to enter by the contrary pole, will reverse the indications of the galvanometer. If the magnet be carried through the helix so as to bring it out at the opposite end to that by which it entered, the effect is the same as if it had been drawn out as before. No current is excited while the magnet and coil are both at rest.

268. Connect the cups of a flat spiral, such as that described in § 123, with the galvanometer; and pass a U magnet over it, towards the centre, with one of its poles above and the other below. The needle will be deflected in opposite directions as it passes on and off. A less effect will be produced by moving a bar magnet

in the direction of a radius over the spiral, or by passing it into the central opening.

269. Let the ends of the coil of insulated wire A, fig. 99, be connected with the gold leaf galvanoscope, described in § 153. Then pass the ring down over one

Fig. 99.

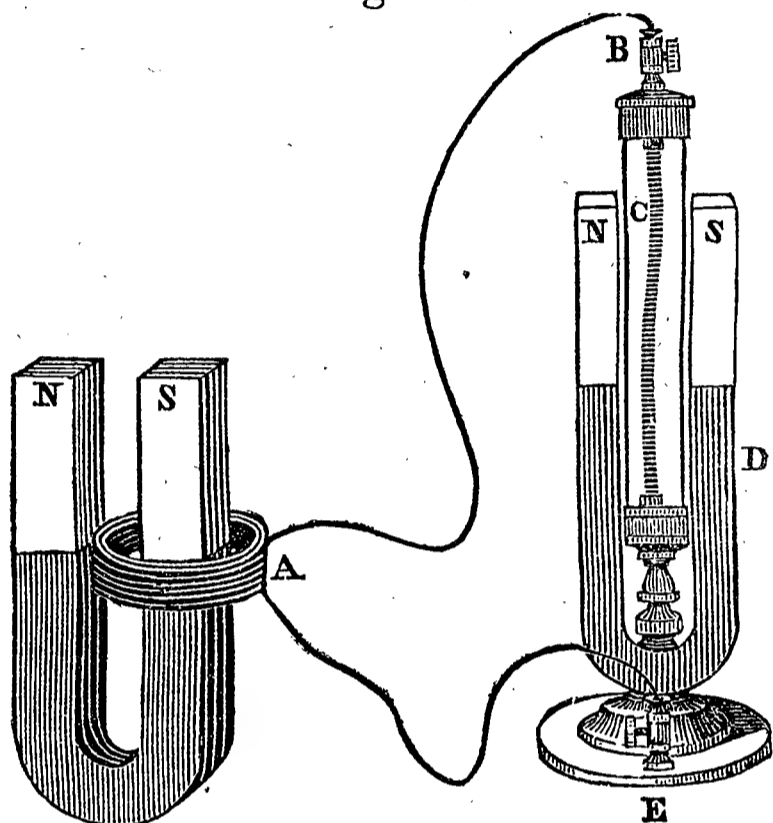

of the poles, say the south pole, of a U magnet. The gold leaf will be sensibly deflected. Take the ring from the south pole and pass it over the north pole. It will be found that the gold leaf is deflected the same way by both these motions of the ring, but in the

opposite direction to what it was previously. Thus drawing it off of one pole and putting it over the opposite pole produce deflections in the same direction, but similar motions, such as putting it over either pole or drawing it off of either, produce opposite deflections. The wire coil A is the same as that described in § 126.

270. Place a bar of soft iron within the helix on stand, fig. 98, its cups being connected with the galvanometer as before. Then bring the opposite poles of two bar magnets in contact with the extremities of the iron. The bar will suddenly be magnetized by induction, and the needle will be deflected. It will, however, immediately return to its former position, the settled

magnetic condition of the bar having no power to affect it. On withdrawing the magnetic poles, the bar loses its magnetism, and the needle is deflected in the opposite direction.

271. By bringing the poles in contact with the iron, and withdrawing them alternately, in such a manner as to keep time with the vibrations of the needle, they may be greatly increased as before. If the two other poles of the bar magnets touch each other so as to form a letter V, the inductive power is much increased. Then by opening and shutting the magnets as if joined by a hinge at the vertex, the bar within the helix may be magnetized at pleasure.

272. When an armature or any piece of soft iron is brought in contact with one or both of the poles of a magnet, it becomes itself magnetic by induction, and by its reaction adds to the power of the magnet. On the contrary, when it is taken away it diminishes the power of the magnet. The approach and departure of iron therefore from the poles of a magnet alters its magnetic state and tends to induce a current of electricity in a coil surrounding it, as may be shown experimentally thus.

EXP. 51.—Pass a wire coil, whose ends are connected with a galvanometer, over one of the poles of a U magnet, as in fig. 99, and keep the magnet and coil stationary. The needle will now be deflected in one direction when an armature is applied to the poles, and in the opposite direction when it is removed.

273. When a galvanometer is used in these experiments, it must be placed at such a distance from the instrument where the magnetic movements and changes are made, that the needle will not be deflected by any influence but that which reaches it through the connect-

ing wires. With the gold leaf galvanoscope this precaution is not needed.

274. **MAGNETO-ELECTRIC ARMATURE.** This instrument consists of an armature of the U form, wound with fine insulated wire and enclosed in a metallic case;

Fig. 100.

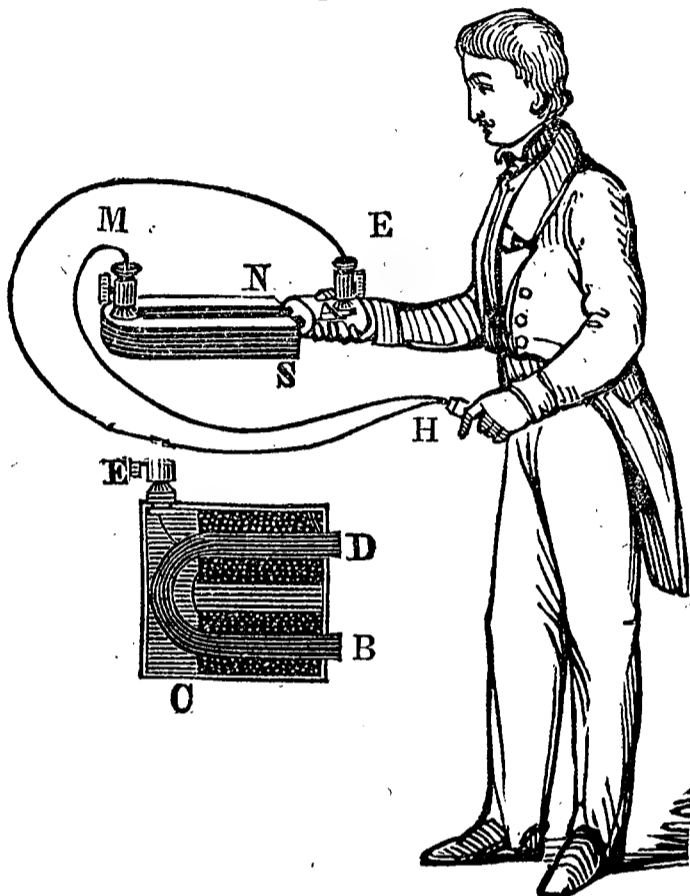

the armature itself is not a solid bar, but a bundle of iron wires. It is seen at A, in fig. 100, and a sectional view of it is given separately. In the section, B D is the armature, having several layers of wire wound on each of its legs, and contained within the case C, from which its ends project slightly. One end of the wire which en-

velops the armature is connected with the case, and also with the armature itself. The other end is soldered to the brass cup E, which is attached to the exterior of the case, but is insulated from it by means of an ivory collar. By this instrument the current of electricity produced by a sudden change in the magnetic state of the armature may be rendered sensible by a strong shock. Let the experimenter bring the ends of the armature in contact with the poles of a powerful compound U magnet, in the manner represented in the figure. In his left hand he holds a metallic handle H, from which two wires proceed; one to the cup M, attached to the U

magnet N S, and the other to the cup E, upon the case of the armature, which he holds in his right hand. It is not essential to have a cup fixed on the steel magnet, as the end of the wire may simply be pressed against it.

275. The apparatus being thus arranged, the experimenter suddenly separates the armature from the magnet by slipping it upwards or downwards from the position represented in the figure. As the armature leaves the magnet, it loses the magnetism which had been induced in it (see § 110), and a current of electricity is in consequence excited in the wire coiled around it within the case. This current passes from the cup E, connected with one end of the enclosed wire, round to the handle H, and thence to the cup M; it then flows through the magnet to the armature itself which is connected with the other end of the wire. The current is excited at the very moment of separation, and passes from the magnet to the armature as a spark of inappreciable length, but at the same time very perceptible. This primary induced current passes only through the metallic conductors or through the short interval of air between the armature and magnet. It is not sufficiently intense to produce the shock which occurs at the moment when the spark passes. This shock is due to a secondary current of higher intensity induced by the primary current in the same wire, at the moment when the circuit through the metallic conductors is broken. This secondary current then passes from the cup E, by the wire E H, through the body and back to the armature, this being the only circuit which is left for its passage.

276. When the armature is first brought in contact

with the magnet, there is of course a change in the magnetic state of the former, and a current of electricity is consequently induced in the wire surrounding it. This current passes through the metallic circuit which is completed at the same time, and induces a secondary current capable of giving a shock were it to pass through the body. But as the metallic circuit remains complete, the secondary current passes through that in preference to the body of the experimenter. It is only therefore when the circuit is broken at the same moment that the primary current is excited, that the shock is obtained from the secondary current induced almost at the same instant by the primary, and which is then obliged, in the absence of some other circuit, to pass through the body.

277. If the wire H M be taken away, no circuit is left for the primary induced current except through the body of the experimenter. If the armature be slipped on and off the magnet under these circumstances, the primary current will pass through the body so as to give a slight shock to the tongue or even to the hands. The shock will be felt both when the armature is brought in contact with and separated from the magnet, though the former will be much the stronger. This is probably owing to the greater suddenness of the change in the magnetic state of the armature when it first touches the magnet, than when it leaves it. In proportion to the quickness of the magnetic change is the intensity of the induced current and the consequent shock.

278. If one of the wires of a galvanometer be connected with the cup E, and the other wire with the case of the armature, the needle will be deflected

strongly in opposite directions whenever the armature is brought in contact with or separated from the magnet. If one of the wires of the galvanometer be connected with the cup M and the other with the cup E, the same result will ensue, although in this case the current flows through the magnet, and has to pass as a spark when the armature and magnet are separated.

279. MAGNETO-ELECTRIC MACHINE, FOR SHOCKS. In this instrument a powerful compound U magnet is mounted on a stand. Before its poles is the armature A, resembling a U armature, although for convenience

Fig. 101.

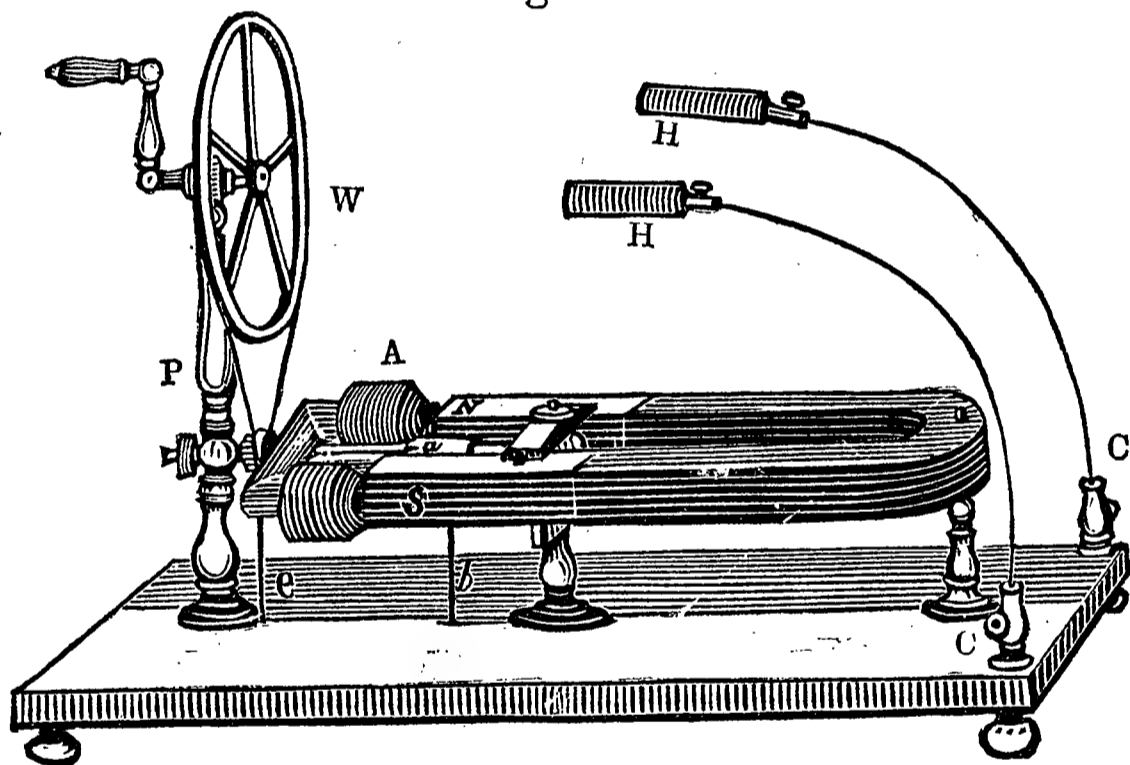

the iron instead of being curved is bent at right angles. It is a solid bar and not a bundle of iron wires as in the last described instrument. Around each pole of this armature is wound a coil of fine insulated wire; the two coils are connected so as to act as a single one. The armature does not quite touch the magnetic poles, and is mounted on an axis of rotation extending from the post P to the central support of the magnet. The upper

part of the post *P* is made to slide over the lower part, and by means of a screw can be fastened in any position. In this way the band connecting the two wheels may be tightened at pleasure by increasing the distance between them. This arrangement also renders the instrument much more portable than it would otherwise be. By means of the multiplying wheel *W*, which is connected by the band with a small wheel on the axis, the armature may be made to revolve rapidly, so that the end of the armature which was one instant opposite to the north pole of the magnet, will be the next instant opposite the south pole, and the one that was opposite the south magnetic pole will be opposite the north pole. A rapid reversal of the magnetism of the armature thus takes place, and electric currents are excited in the surrounding wire. One extremity of the coil of wire is connected with a ferrule or cylindrical piece of silver *a* on the axis of motion, but insulated from it by ivory. The other extremity is attached to the axis and thus connected with the toothed wheel or breakpiece fixed on the axis near the post *P*. A silver wire *b*, flattened at the bearing part, presses constantly against the ferrule *a*, and is connected under the base-board with the wire *e*, which touches from time to time the teeth of the breakpiece during its revolution, thus closing and opening the circuit of the coil in rapid succession.

280. It is evident, on the principle of the Magneto-Electric Armature last described, that if two handles held by an experimenter were connected, one with the ferrule and the other with the breakpiece, that a shock would be experienced whenever the metallic circuit of

the coil was broken. It was shown that at the moment when the induced primary current was interrupted, a secondary current would pass through the body, if that was included in a circuit between the ends of the wire. This is accomplished here by connecting one of the binding screw cups C C with the wire *b* under the base-board, and the other cup with the post P, which has metallic connection with the axis and breakpiece. The body therefore will complete the circuit if interposed between the handles H H, and will receive a shock whenever the primary current is interrupted. A spark is seen when the wire *e* leaves each tooth of the break-piece; if the wire is of iron, beautiful scintillations are produced.

281. In the Magneto-Electric Armature the shock is obtained only when the armature separates from absolute contact with the magnet, but if the primary induced current is broken when an armature is moving towards or away from a magnet, a shock will be felt, though it will be most powerful when the magnet and armature are nearest, as the magnetic action is then greatest between the two. In this instrument the toothed wheel breaks the circuit when the armature is in all possible positions in reference to the magnet. Yet a shock is always obtained, except when the armature is nearly at right angles to the poles. When the armature is made to revolve rapidly by means of the crank and wheel W, the torrent of shocks which results is insupportable. The muscles of the hands which grasp the handles are involuntarily contracted, so that it is impossible to loosen the hold or escape from the infliction.

282. MAGNETO-ELECTRIC MACHINE, FOR DECOMPOSITIONS. In the magneto-electric machine just described, the induced currents flow in opposite directions during

Fig. 102.

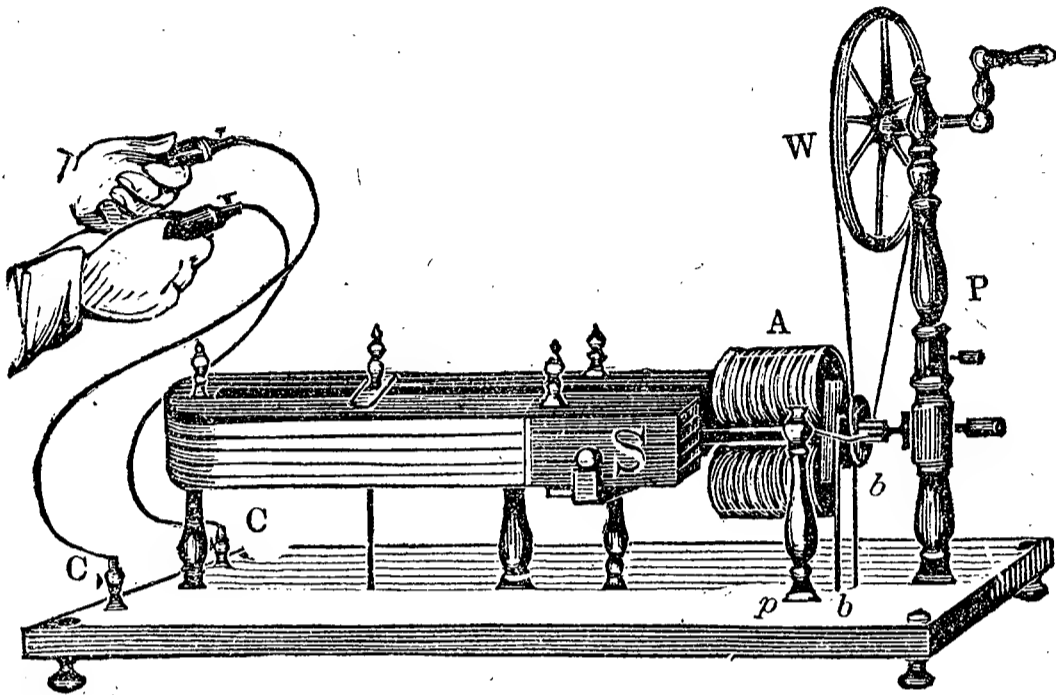

each half revolution of the armature. One pole of the armature, in leaving the north pole of the magnet and approaching the south pole, induces electricity in one direction, but when it passes the south pole and again approaches the north pole, it induces a current in the opposite direction. The principle of the machine now to be described is the same as the last. The modes of connection are modified. Instead of the cylinder *a*, Dr. Page's pole-changer, § 162, consisting of two semi-cylinders insulated from the axis, is substituted. The two extremities of the coil surrounding the armature are soldered to these. Two flattened silver wires *b b* press against the opposite sides of the pole-changer, and are connected under the base-board with the cups *C C*. These are the only connections used in producing decompositions, the circuit not being broken. The effect

of the pole-changer is to change the end of the coil which communicates with either cup every half revolution. But as the current itself flows in opposite directions in the coil each half revolution, the result is that one of the cups is constantly positive and the other negative. The current flows between them, if they are connected, always in one direction, unless the revolution of the armature is reversed.

283. To enable this machine to afford strong shocks, one of the wires *b b* is also connected with the post *P*, and thereby with the axis and breakpiece. The other wire is connected with the pillar *p*, which has a binding screw at the top, in which a wire can be fastened to play against the breakpiece and break the circuit, as in the last described instrument. All the effects produced with the other machine may be equally well shown with this. The flow of the current in a constant direction also allows of the performance of many additional experiments.

284. When the metallic handles attached to *C C* are held in the hands, the arm connected with the negative cup will be found to be most affected by the shocks. This is a physiological phenomenon, the current producing a greater effect upon the arm in which it flows in the direction of the ramification of the nerves, than upon the one in which it ascends. The initial secondary is too feeble to afford shocks, so that only the terminal secondary need be taken into account. The intensity of the terminal shock is however constantly varying, according to the position of the armature in respect to the magnet, and the difference in the effect

upon the two arms is not so well marked as with some of the instruments which will be described hereafter.

285. Slight shocks may be obtained from the primary current, as in the case of the Magneto-Electric Armature, by grasping the metallic handles connected with the cups C C. The wire which rests on the breakpiece must be removed so that the circuit may not be broken. If the cups be connected with those belonging to the inner coil of the Double Helix and Electrotome (§ 245), and the central opening of that instrument be filled with iron wires, secondary shocks of considerable strength will be obtained from the exterior helix whenever the armature is made to revolve. The vibrating wire should be put in motion to break the primary circuit. Bright sparks are also seen in the mercury cups. The sparks are conveniently shown by passing the primary current of the machine through the Contact Breaker, § 229, the wire W W being made to vibrate.

286. When the primary magneto-electric current is made to pass through water in a constant direction, the water is resolved into its elements, and the gases hydrogen and oxygen are given off separately, by the two wires which convey the current. If the direction of the current alternates, the water is still decomposed, but the gases cannot be obtained separately as both are given off from each wire. The other machine is able to decompose water, though very feebly, because the connections are such that only the secondary current can be used.

287. Two platinum wires being connected with the cups C C, and their ends immersed in water, a slender

stream of gas will be seen to escape from each wire when the armature is made to revolve. If the wires are of iron or copper, the oxygen will unite with the one connected with the positive cup to form oxide of iron or of copper, and hydrogen alone will be given off. Platinum wires are not attacked by the oxygen, and are therefore best for conveying the current. The decomposition of water is greatly facilitated by dissolving in it some salt, as for instance, Glauber's salt, or what is still more effectual, by the addition of one part of sulphuric acid to ten or fifteen of the water. These substances increase its conducting power.

288. Fig. 103 represents a Decomposing Cell mounted on a stand, and designed to be used with this machine.

Fig. 103.

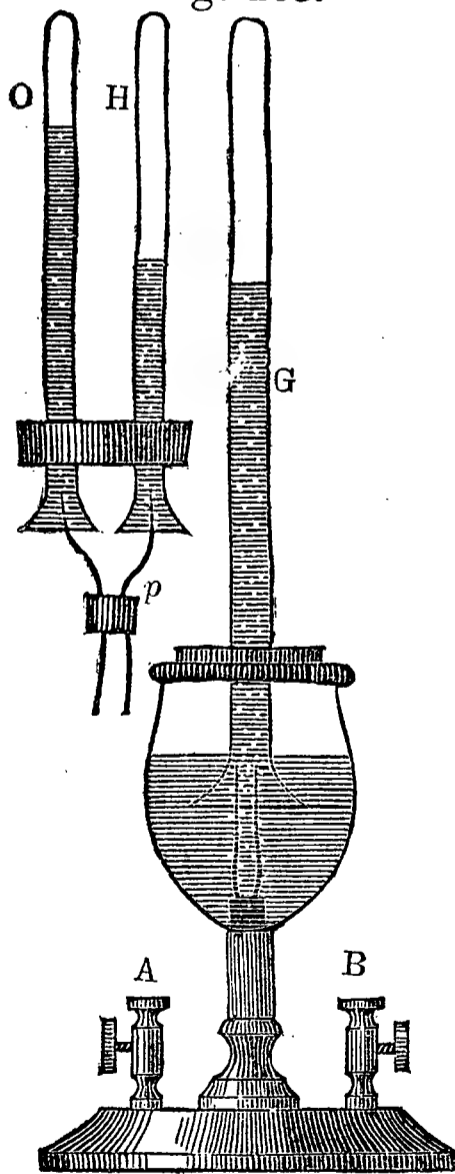

Two platinum wires connected with the cups A and B on the stand pass up into the cell, which is of glass. A glass tube G may be inverted over these wires to collect any gas which is evolved; it passes through a cork fitting the mouth of the cell with sufficient tightness to allow the tube to be filled with the liquid by merely inverting the instrument. The cell being partly filled with acidulated water, and the tube wholly full, connect the cups A and B with those of the machine. As the wheel W is turned, bubbles of gas will be seen to escape from

each wire, and to rise into the tube, displacing the liquid from it. When the tube is full, it may be removed and the mixed gases exploded by holding its mouth to a flame.

289. By having two glass tubes O and H passed through a cork so that one of them may be inverted over each wire, as shown in the cut, where *p p* are the platinum wires, the gases may be obtained separately; oxygen only being collected in the tube placed over the positive wire, and hydrogen alone in the other. The volume of the latter gas is twice that of the former, as indicated in the figure by the relative height of the liquid in the tubes O and H, occupied respectively by the oxygen and hydrogen. On removing the tubes when full, the hydrogen will burn if a flame be applied, and the oxygen will increase the brilliancy of the combustion of any ignited body put into it.

290. With a good machine, one cubic inch of the mixed gases will be liberated in from five to ten minutes. If the conducting power of the liquid be made too great the evolution of gas will be lessened. Strips of platinum foil, which are superior to wires in decomposing by a compound galvanic battery, do not answer so well with the magneto-electric current, especially when the wire coiled upon the armature is fine.

291. The primary current is able to decompose various saline solutions. For this purpose some porous partition should be interposed between the portions of liquid in which the wires are placed, in order to prevent their too ready admixture. These experiments may be performed in the Decomposing Cell, fig. 103, by placing

a piece of unsized paper across it, between the wires ; it need not fit closely the sides of the cell. A better in-

Fig. 104. strument for the purpose is a glass tube bent

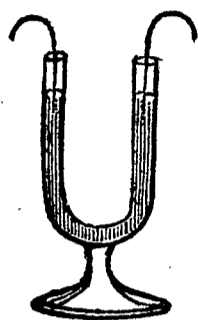

into the form of the letter U, as shown in *fig. 104.* A loosely crumpled piece of unsized paper, or of cotton cloth, may be thrust into the bend of the tube as a partition, thus dividing it into two cells.

292. The tube being partly filled with a solution of some neutral salt to which has been added enough of the infusion of red cabbage to give it a blue color, let two platinum wires connected with the cups of the machine be immersed, one in each portion of the liquid. When the armature is made to revolve, the blue color will soon be changed to red in the cell containing the positive wire ; and to green in the other, provided the salt has an alkaline base. By reversing the motion of the armature, the original color will be first restored in each leg of the tube, and then the opposite change will occur. If the solution be colored blue by the infusion or tincture of litmus, it will become red in the cell in which the acid is developed, but will suffer no change in the other. When the yellow infusion of turmeric is used, it is turned brown by the alkali evolved in the negative cell, but is not affected by the acid in the other.

Exp. 52.—Let the tube contain a weak solution of Glauber's salt (sulphate of soda), colored blue by the infusion of red cabbage. On transmitting the current, sulphuric acid will be liberated in one cell, changing the blue to red ; and soda in the other, changing it to green. Similar phenomena present themselves with a large number of salts, but in some cases different effects are produced.

Exp. 53.—If a solution of muriate of ammonia, colored by some vegetable infusion, be employed, chlorine gas will be given off from the positive wire; this may be recognized by its peculiar odor and by the bleaching effect it produces upon the liquid in the positive cell, which quickly becomes colorless. In this case ammonia and hydrogen are set free in the negative cell, and muriatic acid and oxygen should have been liberated in the other. The chlorine appears therefore to be a secondary product, set free by the combination of the hydrogen of the muriatic acid with oxygen, to form water.

Exp. 54.—Let the tube be filled with a weak solution of hydriodate of potash, without any coloring liquid. By causing the armature to revolve, iodine will be abundantly liberated round the positive wire; this being slightly soluble gives a brown color to the liquid, but most of it remains in suspension, forming a dense cloud. If a few drops of a weak solution of starch had been previously added, an intense blue color will be developed. The hydriodate of potash is more easy of decomposition than any other salt; even the current of a single galvanic pair will liberate iodine from it.

Exp. 55.—When a solution of sulphate of copper is employed, sulphuric acid and oxygen are set free in the positive cell, and metallic copper is precipitated upon the negative wire. If the current is powerful, it is deposited as a slightly adherent black powder; but if of moderate strength, a thin coating is formed, possessing the proper color and appearance of the metal. In this case little or no hydrogen escapes from the coated wire, though oxygen is given off by the positive one. On reversing the current, the copper will be gradually dissolved from off the coated wire, and a similar deposit will occur on the other. No oxygen escapes from the wire which is now positive until its coating has nearly disappeared. When the experiment is concluded, the deposited copper may be removed from the platinum wires by a little diluted nitric acid. If two copper wires be immersed in the solution, as much copper will be dissolved off of one as is deposited upon the other. Sulphuric acid does not act upon copper in the cold unless aided in this way by an electric current.

Exp. 56.—Let the tube contain a diluted solution of muriate

of gold, the conducting wires being of platinum. The negative wire will soon become covered with a coating of gold, which increases in thickness as the current is continued. Other metals, as for instance, silver, copper and brass, may be thus gilt; the coating does not adhere very firmly unless the metallic surface on which it is to be deposited has been perfectly cleaned by acid. The positive wire should always be of platinum or gold. The ethereal solution of gold may be employed in this experiment. It is made by mixing ether with a strong solution of the muriate; the ether containing the gold rises to the surface and may be poured off from the acid.

293. Many other metallic salts may be decomposed in the same manner, and the metals precipitated, but in most cases the deposit is of a black color. In precipitating metals, both wires may be in the same portion of liquid, no partition being required; in fact, if the tube is of considerable length it will not be necessary in the other experiments. The deposition of the metals from their solutions in these cases depends upon the same principles which are concerned in the electrotype process to be described hereafter.

294. The galvanometer is strongly affected by the primary current. Even a large and heavy needle surrounded by a single wire, as in the instrument represented in fig. 29, may readily be deflected. A sewing needle or a piece of steel wire placed in the magnetizing helix (fig. 94), will be fully charged. If an iron wire be introduced into the helix, its ends will sustain a considerable quantity of iron filings during the flow of the current.

295. When the extremities of the wire surrounding a small electro-magnet, such as is represented in fig. 53, are fixed in the cups C C, it will be able to sustain a weight of some ounces while the primary current is

flowing. If the electro-magnet be covered with four or five layers of coils, the wire being in a single length, it will lift several pounds.

296. The primary magneto-electric current resembles a galvanic current excited by a number of small pairs. Its quantity and intensity are, however, both greatly influenced by the size and length of the wire enveloping the armature. A short wire of large diameter gives a current of moderate intensity but of considerable quantity, and is therefore best for producing sparks, decompositions and magnetism. A long and fine wire affords a current of small quantity and high intensity, and is most suitable for giving shocks.

297. PAGE'S REVOLVING MAGNET, AS A MAGNETO-ELECTRIC MACHINE. This instrument exhibits the mag-

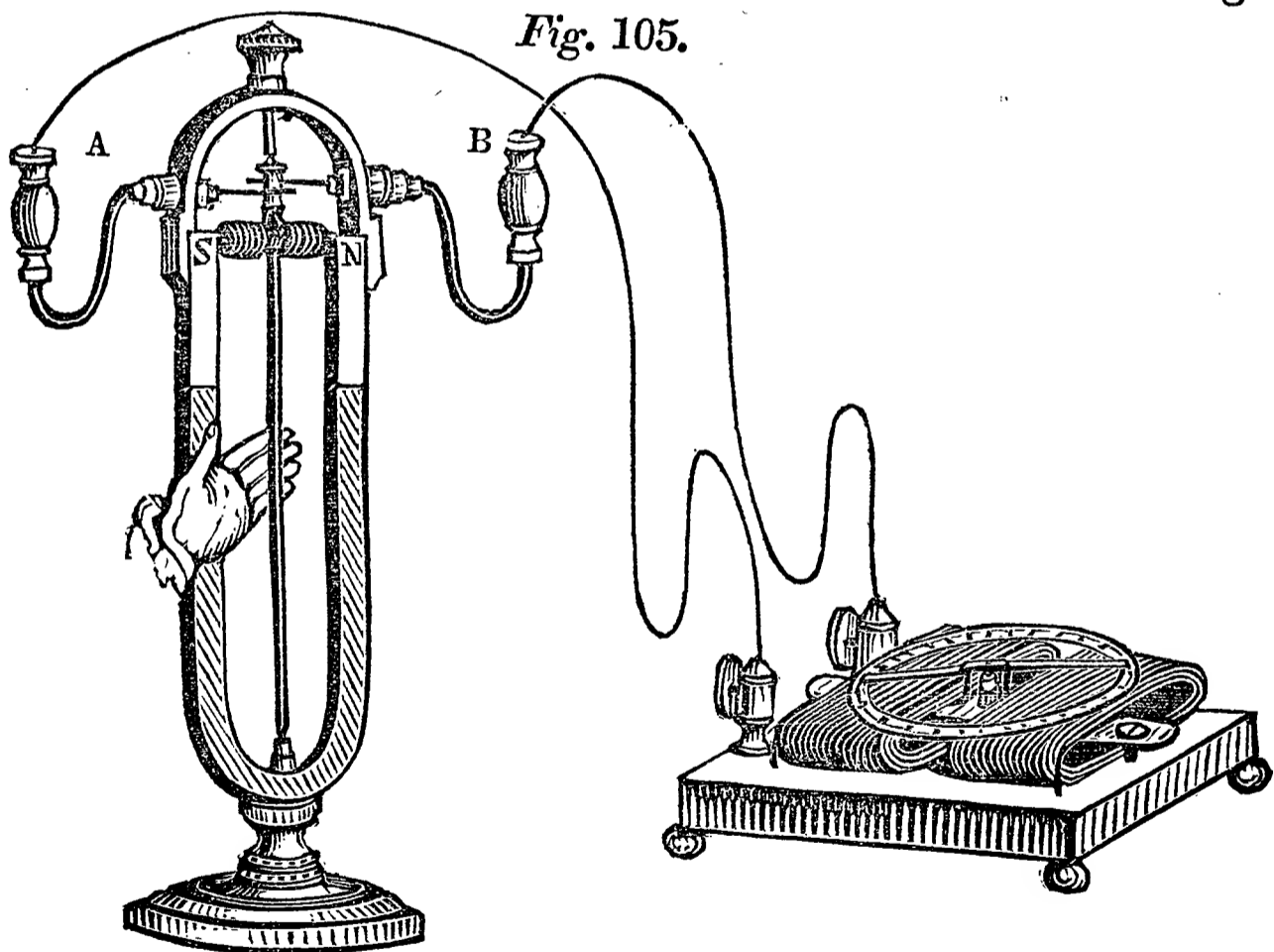

neto-electric machine in its most simple form. A soft iron bar capable of revolving between the poles N S of

the U magnet is wound with wire, and its extremities connected with the cylinders of a pole-changer fixed on the axis of motion. Two silver springs pressing on this convey the induced current to the cups A and B. The instrument has been described in § 171.

298. The cups A and B being connected with those of a galvanometer with an astatic needle (§ 87), as represented in the figure, the needle will be powerfully deflected when the bar is made to rotate rapidly by drawing the hand over the axis. By reversing the motion of the bar several times in correspondence with the oscillations of the needle, it may be made to revolve rapidly. With a sufficiently delicate galvanometer, any of the electro-magnetic instruments in which motion is produced by the mutual action between a galvanic current and a steel magnet, may be made to afford a magneto-electric current by producing the motion mechanically. In all cases the current excited flows in the opposite direction to the galvanic current which would be required to produce the same motion.

299. If the cups A and B be connected with the cups C and C' of the Double Helix and Electrotome, slight secondary shocks, which may sometimes be felt in the hands, will be obtained from the fine wire helix by rotating the iron bar, as in the figure. The hollow of the double helix should be filled with iron wires, and the vibrating wire be put in motion so as to break the circuit rapidly.

300. In the magneto-electric instruments which have been described, steel magnets are employed, and mechanical motion is made use of to excite the electrical current; in those which remain, the current is induced

by an electro-magnet whose magnetism is alternately acquired and lost. The instruments consist essentially of double helices containing bars or wires of soft iron. The magneto-electric current is thus obtained in conjunction with that excited by electro-dynamic induction, and the combined current is called a *secondary*, though only in part such.

301. SEPARABLE HELICES. This instrument is represented in fig. 106. The external helix is of fine wire

Fig. 106.

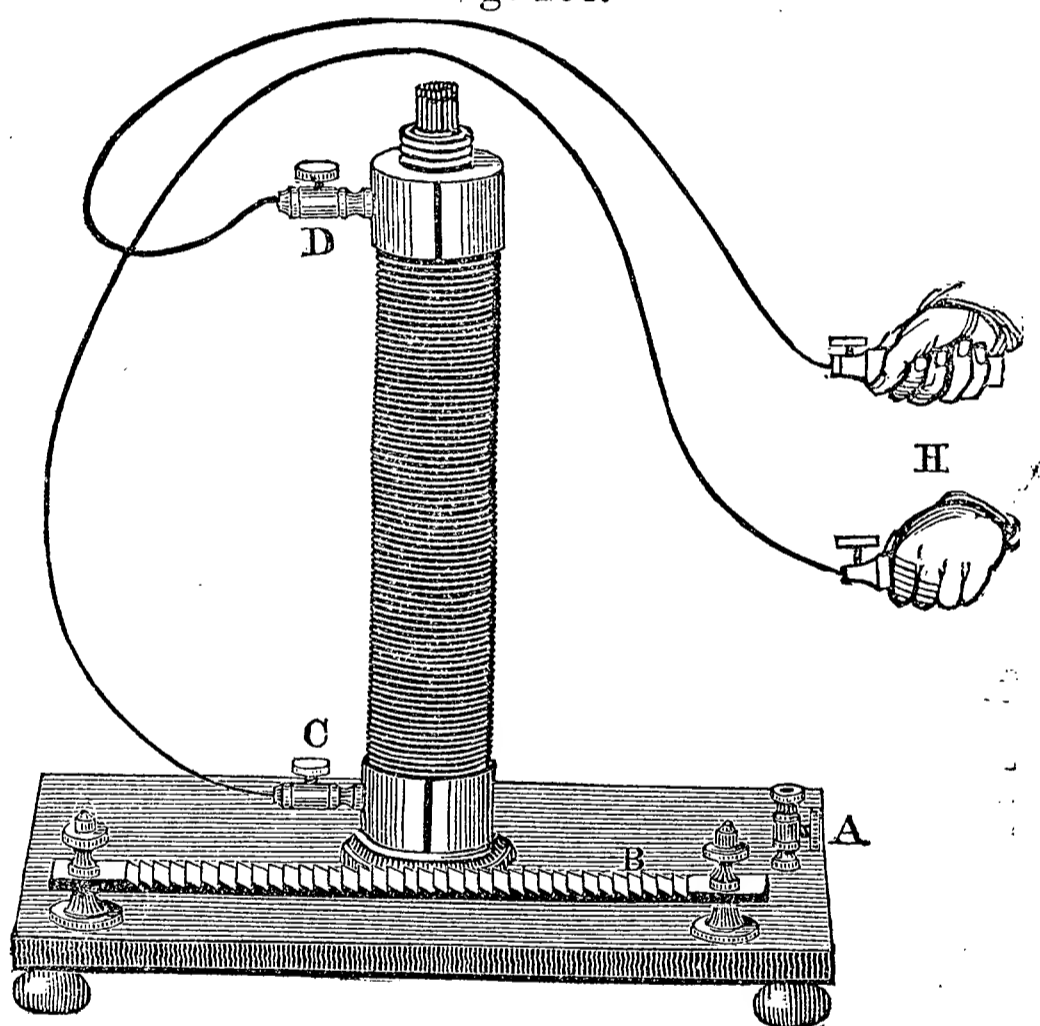

from one to three thousand feet long. It is made wholly separate from the interior helix and can be lifted directly off, as is shown in fig. 107, where *a* is the exterior coil, and *b* the interior one. The ends of this helix are enclosed in two brass caps to which the extremities of the fine wire are attached, and from which proceed the binding screw cups C and D. The inner helix, which is

fixed in a vertical position on the stand, consists of three or more strands of coarse copper wire each about twenty-

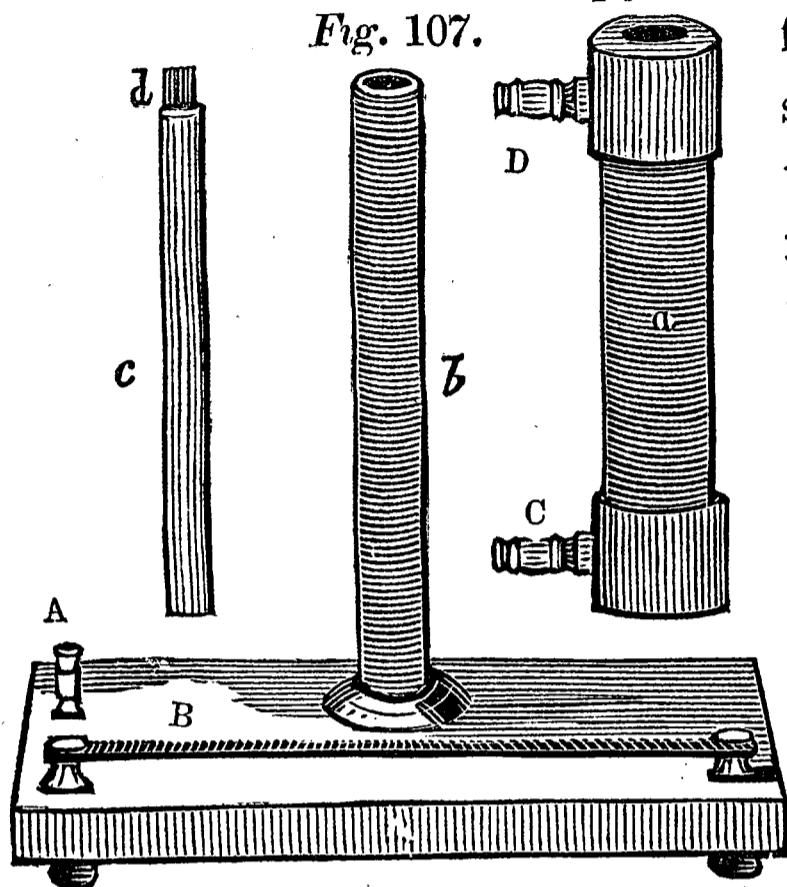

five feet long. The similar extremities of these wires are connected at one end with the cup A, and at the other with the steel rasp or break-piece B. If one wire of a galvanic battery be fixed in the cup A, and the other be drawn over the rasp, sparks will be seen; and if handles be connected with the cups C D, slight shocks will be felt when the circuit is completed, and strong ones when it is broken. The instrument thus resembles the double helix described in § 245.

302. If a rod of soft iron be introduced into the centre of the helix the spark is very much increased, brilliant scintillations are produced, and the shock when the circuit is broken becomes intolerable. The iron acquires and loses magnetism whenever the circuit is made and broken and induces a secondary current in both of the coils which surround it. In the coarse wire coil, which also conveys the battery current, this appears in the increased sparks and scintillations. In the fine wire coil it is felt in the violent shock which results.

303. Slight shocks may be obtained from the inner coil itself by connecting one of the handles with the cup

A, and the other with the rasp B. The bundle of iron wires seen at *d* should be within the helix. The shocks are somewhat stronger when one handle is in connection with the rasp and the other with the battery wire which is drawn over it; in this case the battery is included in the circuit of the secondary current.

304. If the bundle of annealed iron wires seen at *d* be removed from the brass tube *c*, and substituted for the soft iron rod, the spark and shock are much increased. If the rod or bundle of wires be introduced gradually into the helix, the spark and shock increase as it enters. The intensity of the shock may also be varied at pleasure, by altering the number of iron wires, the addition of a single wire producing a manifest effect. If a glass tube be slipped over the iron wires in the helix, it will not interfere with their inductive action on the surrounding coils. But if a brass tube be passed over them, their influence will be entirely suspended, as far as the shock and the spark are concerned. If the tube be slipped partly over them, their influence will be partially suspended. Here also is a means of regulating the shock with the same battery current.

305. The cause of the neutralizing action of the tube is thus explained. The magnet induces in the tube, as well as in the two coils, a secondary current of electricity, which flows round it when the circuit is made or broken. This secondary induces a tertiary current in both the coils, which flows at the first instant in an opposite direction to the secondaries induced in the coils by the magnet, and therefore retards them. As the secondary current in the tube is, however, instan-

taneous, it induces another tertiary in the same direction with itself when it ceases to flow. The consequence is that the quantity of the current in either helix is not altered, but its intensity is reduced, owing to the slowness of its development. This is always the effect of any closed circuit in the neighborhood of an inducing magnet or current, on other circuits near it.

306. If the cups of the fine wire coil be joined by a wire, it will form a closed circuit around the magnet, and will impair the spark when the circuit of the coarse wire coil is broken, though not to so great an extent as the brass tube, since the latter offers a freer and shorter circuit for the induced current. The spark is but slightly lessened when shocks are taken from the fine wire coil, because the human body is too poor a conductor to allow of the ready flow of the secondary through it. A metallic cylinder surrounding the helices will neutralize the sparks and shocks as well as an enclosed tube.

307. When a bar of iron is placed in the centre of the coil, a secondary is induced in it as in the tube, which somewhat retards the secondary currents in the coils. Hence the greater shock obtained from a bundle of wires, where this secondary current cannot circulate. To this cause is probably added another, the more sudden change in the magnetism of the wires, when the battery current ceases, from the neutralizing influence of the similar poles of the wires on each other.

308. If the secondary current can be hindered from circulating in the brass tube, its retarding influence will be prevented. Thus, if the tube be longitudinally divided

on one side, it no longer diminishes the shock or spark. In the same manner if the bar of soft iron be sawed through to its centre, longitudinally, the shock and spark will be increased. If a soft iron tube be divided like the brass tube and placed in the helix, the shock will be still stronger, though never so great as with the wires. The two brass caps at the ends of the fine wire coil would exert a considerable neutralizing influence if they were not divided on one side, as is represented in fig. 106. The ends of the caps are also cut through for the same reason.

309. In this instrument there are some peculiarities in the shock occasioned by the motion of the battery wire over the rasp. If it is moved slowly, powerful, distinct shocks are experienced; if the motion is quickened, the arms are much convulsed; and if it is drawn over rapidly, the succession of shocks becomes intolerably painful. This however can be easily regulated. The shock from the secondary coil increases within certain limits in proportion to the length and fineness of the wire of which it is composed. There is, however, no advantage in employing a very long wire, unless the battery is powerful. The shock will also be lessened if a very fine wire is used, except its length be moderate.

310. The strength of the shock depends greatly upon the extent of the surface of contact between the hands and the metallic conductors. Thus, if two wires be fixed in the cups of the outer coil and grasped in the hands, the shocks will be slight in comparison with those given by the handles, and still more so if the wires are held lightly in the fingers. These effects, as

well as the increase of the shock by wetting the hands, are due to the comparatively low intensity of the secondary current, which causes it to be transmitted very imperfectly by poor conductors. With frictional electricity it is well known that no difference in the shock is thus occasioned.

311. When the quantity of the secondary current is very small, an imperfect conductor or a surface of limited extent may be able to convey the whole of it, even if its intensity be not very high; in which case the sensation and muscular contractions produced by it will not be increased, but often lessened, by any farther increase of the conducting power. Thus, if the shocks are received by placing the hands in two vessels of water connected with the cups of the outer coil, and the current be rather feeble, it will produce the strongest sensation when the ends of the fingers only are immersed. When the current is powerful, the shock is intolerable, whether the surface of contact with the water be large or small; in the latter case it extends to a less distance up the arms, though it may be felt very strongly in the fingers.

312. The shocks have sufficient intensity to pass without much diminution through a circuit formed by several persons with their hands joined, especially if their hands are moistened. Different individuals will be found to manifest remarkable differences in regard to susceptibility to the shocks; some being but slightly affected, perhaps feeling the shocks only in the hands or arms; while others will feel them as far as the shoulders or across the breast, and will experience strong muscular contractions in the arms.

313. The difference in the strength of the shock in the two arms, which has been described in the case of the Magneto-Electric Machine (see § 284), is exhibited more satisfactorily by the separable helices, as a rapid succession of shocks may be obtained of very nearly the same intensity. Suppose the handle connected with the positive cup of the exterior helix to be held in the right hand, and the one connected with the negative cup in the left hand. The left hand and arm will then experience the strongest sensations and be the most convulsed. In determining the positive or negative character of the cups, regard should be had only to the terminal secondary current, it being found that the initial secondary, whether induced by means of a voltaic battery or a permanent steel magnet, produces comparatively feeble physiological effects, and consequently need not, in this case, be taken into account. This singular difference in the intensity of the shocks is regarded as a purely physiological phenomenon, the greatest effect both as respects sensation and muscular contractions being produced by the electric current when it proceeds in the direction of the ramification of the nerves.

314. If the ends of the secondary wire are put into vessels of water, a peculiar shock may be taken by putting the fingers or hands into the vessels, so as to make a communication between them through the body. If both wires be put into a trough, at some distance apart, and two fingers of the operator be placed in the water in a line between the two wires, a shock will be felt. Here the current prefers a passage through the body to that through the water which intervenes be-

tween the fingers. The conducting power of the water may be made better than that of the human body by the addition of a sufficient quantity of common salt; in which case little or no shock can be perceived. If the fingers be placed at right angles to the line between the wires, no shock will be felt. The trough should not be of metal, but of some poor conductor of electricity.

315. If a delicate galvanometer be connected with the ends of the fine wire coil, the needle will be deflected in opposite directions and equally far when the battery circuit is closed and opened. The same effect is produced when the brass tube is slipped over the iron wires. In this case, though the shock may have been prevented, the induced current still evidently passes.

316. When a flat coil of fine wire, such as that represented at *W* in fig. 95, is passed over the interior helix (the exterior one being removed), the shocks will be found to be strongest when the coil surrounds the middle of the helix, and to decline considerably in strength as it is either raised or depressed from this position. Now the magnetism of the enclosed iron wires, which induces the principal part of the current, manifests itself chiefly at the ends of the bundle; it might therefore have been expected that the flat coil would give the strongest shock when surrounding one of these ends. The shocks from the exterior helix are also lessened when it is raised from the stand so as to enclose only the upper part of the inner helix.

317. This instrument is convenient for illustrating some of the most important principles of magneto-electric and electro-dynamic induction, in consequence of

the facility with which the powers and uses of its several parts can be separately exhibited. The observations which have been made with regard to this instrument apply equally well to the two following, which are modifications of it.

318. SEPARABLE HELICES AND ELECTROTOME. In the instrument represented in fig. 108, the inner helix is connected with an Electrotome or Contact Breaker,

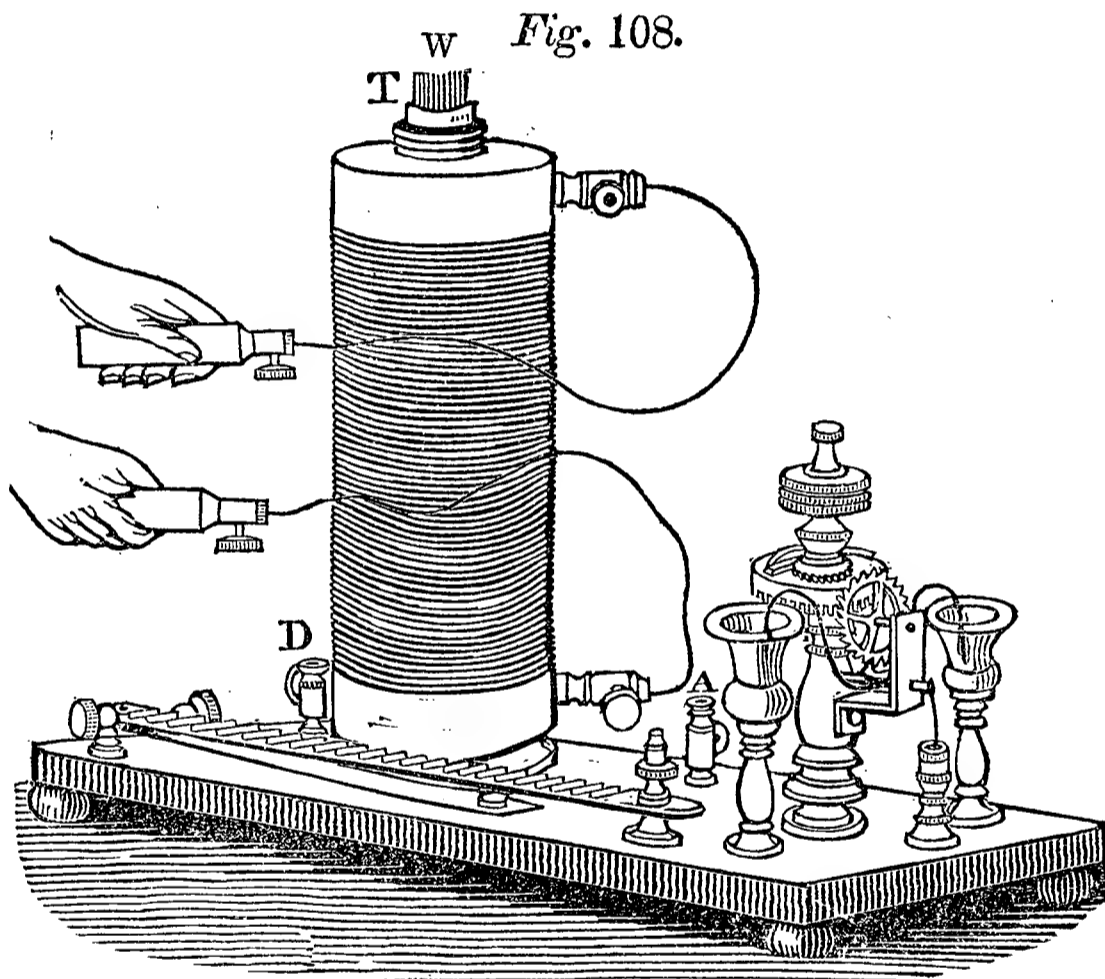

similar to that described in § 229, fixed on the same stand, in addition to the steel rasp. There are two cups A and D for the battery wires; these are connected through the electrotome with the inner coil. When the electrotome is made to vibrate, the curved wire dips its ends alternately into the cups of mercury, and rapidly breaks the circuit. One end of the coarse wire coil is also connected with the steel rasp, so that

this may be used as in the last instrument, when the current is not made to pass through the electrotome. At W is seen the end of the bundle of wires, and at T the brass tube, which may be slipped over them at pleasure.

319. This instrument, and others resembling it in being provided with a mechanical contrivance for breaking the battery circuit, may be used with a very small battery, although its effects are of course most striking with a powerful one. If a voltaic pair, consisting of a silver dollar and a piece of zinc of the same size be used, and the helix be filled with soft iron wires, the shock is quite severe.

320. When the circuit is broken at the surface of the mercury, an intensely brilliant spark is seen, and the mercury is consumed or deflagrated, passing off in a white vapor. If the quantity of mercury be properly adjusted, the sparks occur alternately in the two cups, and in such rapid succession as to appear simultaneous. A little water or oil poured upon the surface of the mercury diminishes the brilliancy of the sparks, but increases the intensity of the shocks.

321. These sparks are of so short duration that moving objects appear stationary by their light. One of Page's Revolving Armatures, although rotating many hundred times a minute, appears at rest when viewed in this way; and where the sparks succeed each other rapidly, it appears to leap from place to place as their light falls on it. Many optical illusions of this kind may be observed, as in moving the fingers rapidly, when their number seems increased, or rapidly turning over

the leaves of a book, when they seem to leap in the same manner as the armature.

322. If the ends of the secondary wire be separated from each other at the same moment that the battery circuit is broken, a spark will be seen from the passage of the induced current. A beautiful light is produced if prepared charcoal points are attached to the ends of the secondary wire and held almost in contact.

323. Water may be decomposed by connecting the ends of the fine wire coil with an instrument for that purpose, having very small platinum wires guarded with glass, as originally used by Wollaston. These are prepared by inserting the wires into capillary glass tubes, which are heated till the glass melts and adheres to their ends so as to cover them completely. The platinum points are then exposed by filing away the glass. Or the wires may be thickly coated with sealing-wax which is afterwards to be removed in the same way from their points. It is of course only necessary to coat those parts of the wires intended to be immersed in the fluid.

324. The extremities of the platinum wires, while the decomposition is going on, appear in a dark room, one constantly and brightly, and the other intermittingly and feebly luminous. If the apparatus for decomposition is removed out of the noise of the electrotome, rapid discharges are heard in the water, producing sharp ticking sounds, audible at the distance of eighty or one hundred feet, and synchronous with the ruptures of the voltaic circuit. Decomposition is effected both by the initial and terminal secondary currents, that is to say, by the currents induced both on completing and on

breaking the battery circuit; but the ticking noise and sparks accompanying the rapid discharges in the water, are produced only by the terminal secondary current. Both gases, hydrogen and oxygen, are given off in small quantities at each wire. The secondary current of the magneto-electric machine presents the same phenomena with the guarded points.

325. A Leyden jar, the knob of which is connected with its inside coating by a continuous wire, may be feebly charged, and slight shocks be rapidly received from it, by bringing the knob in contact with one of the cups of the outer helix, and grasping with the two hands respectively the outer coating of the jar and a handle connected with the other cup. A gold leaf electroscope is readily affected by touching its cap with a wire fixed in either cup of the exterior helix. If the contact, which should only be momentary, is made at the instant of the rupture of the primary circuit, the gold leaves will exhibit a considerable divergence without the aid of a condenser. Or the knob of a Leyden jar may be touched for a moment with the wire, when it will be found to retain a feeble charge, capable of diverging the gold leaves and of giving a slight shock. The wire must be well insulated from the hand in which it is held, or the electricity will be conveyed off, and no accumulation be obtained.

326. If the cups of the large Thermo-Electric Battery (fig. 15) be connected with A and D, and the vibrating wire be put in motion, faint sparks will be seen in the mercury cups, attended by audible snaps; and strong shocks may be obtained by grasping the handles

attached to the fine wire coil, especially if both heat and cold are applied to the battery. A single thermo-electric pair of antimony and bismuth, or of German silver and brass, will give a slight shock to the tongue when heated by a spirit lamp: it will be more perceptible when the ends of two wires fixed in the cups are made to touch the tongue than with a more extended surface of contact. This is probably due to the small quantity of the induced current, as has been mentioned in § 311. These sparks and shocks are, of course, not strictly thermo-electric but magneto-electric.

327. When a bar of iron is contained within a horizontal helix, such as is represented in fig. 96, where the circuit can be rapidly broken, and a small key or some nails are applied to one end of the bar, notwithstanding its magnetic attraction is intermitted every time the voltaic circuit is interrupted, yet, it being almost instantaneously renewed, they do not cease to be sustained. This experiment succeeds best when the iron bar is enclosed in a brass tube previously to being introduced into the helix, the closed circuits of the tube tending to prolong its magnetism.

328. If an iron tube of sufficient diameter to admit a long helix of fine wire within it be itself passed within a coil of coarse wire, no shocks can be obtained from the enclosed helix, even when the tube is divided longitudinally on one side, to prevent the flow of a current in its substance which might neutralize that of the fine wire. It has been stated in Exp. 27, that a galvanic current passed through a coarse wire helix, enclosed in an iron tube, induces no magnetism in it.

329. SEPARABLE HELICES AND REVOLVING ARMATURE. Another form of the separable helices is rep-

Fig. 109.

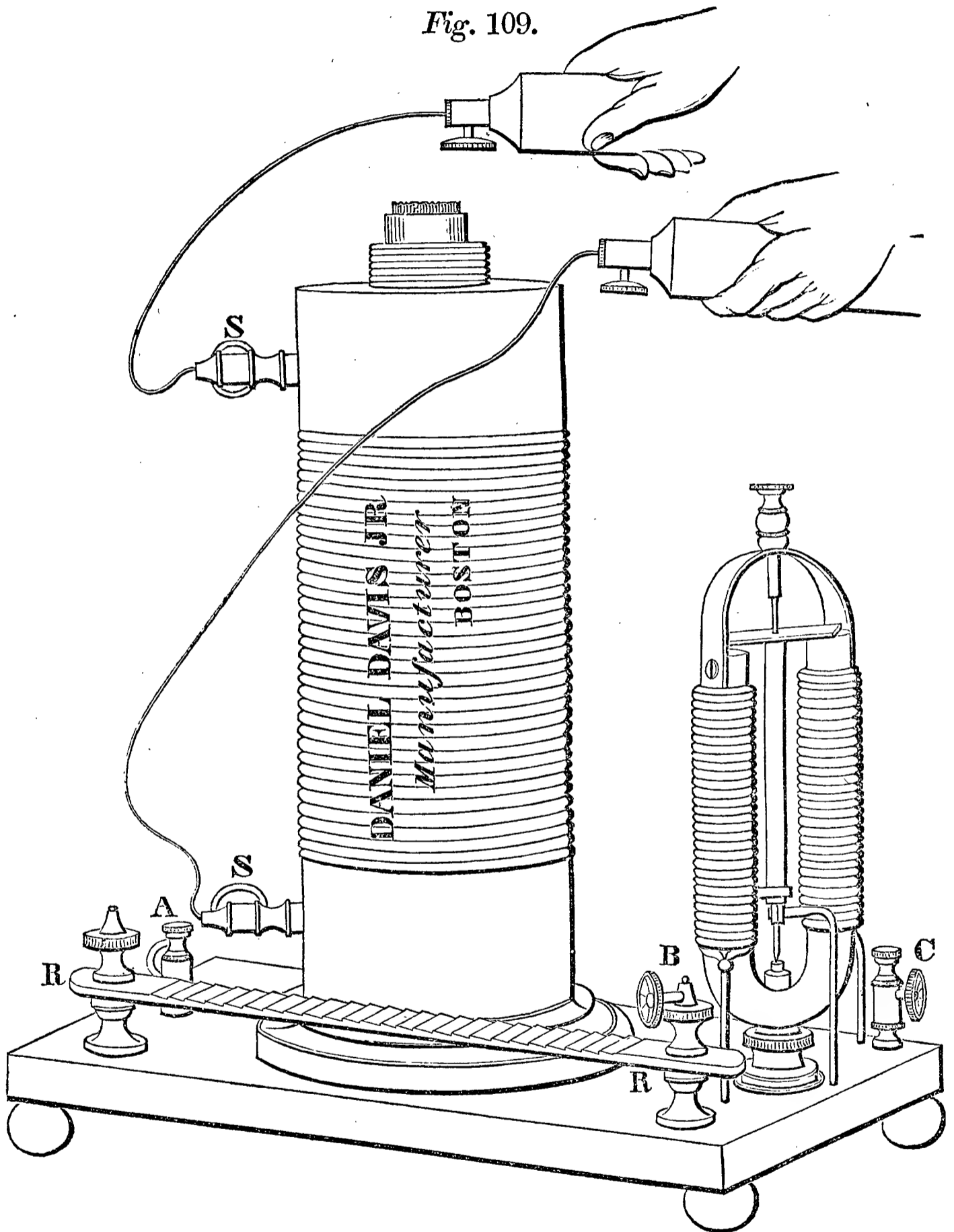

resented in fig. 109. When the battery wires are connected with the cups A and C, the current flows through the coarse wire coil, and also through Page's

Revolving Armature, which is attached to the stand. This is a modified form of the instrument described in § 182. The armature revolves rapidly, and breaks the circuit each half revolution. The rasp R R is also connected with one end of the battery coil, so that if the battery wire be removed from the cup C and drawn over the rasp, the current will be interrupted and scintillations produced. In this instrument and those which immediately follow, the apparatus for breaking the circuit is self-acting,—a very interesting feature. The motions are readily produced by the smallest battery ordinarily employed for these purposes.

330. With a battery of even moderate power, the shocks may be made to follow each other with exceeding rapidity. When their strength is lessened considerably by removing nearly all the iron wires from the centre of the helices, it will be found that with this rapid succession instead of distinct shocks a peculiar sensation of numbness is experienced, extending a greater or less distance up the arms, and attended by loss of power over the muscles as far as it reaches.

331. The shocks are never so powerful with this instrument as with the one last described, supposing the length of the coils to be the same; because the battery current is obliged to maintain the motion of the armature as well as to traverse a circuit of greater length. This reduction, which is not however very considerable, may be avoided by uniting the cup B with one of the binding screw cups of the Contact Breaker (§ 229), and fixing one of the battery wires in the remaining cup of that instrument and the other in the cup A.

332. When the cups S S are united by a wire, the

speed of the revolving armature is altered to some extent, in consequence of the prevention of the secondary current which would otherwise be excited in the inner helix, and which prolongs the magnetism of the U magnet after the breaking of the circuit. It will depend upon the position and pressure of the springs upon the breakpiece whether the motion is accelerated or retarded by this circumstance.

333. PAGE'S REVOLVING ARMATURE FOR SHOCKS. The instrument represented in fig. 110 consists of a U electro-magnet wound with a coil of fine wire for shocks, in addition to the coarse wire coil for the battery current.

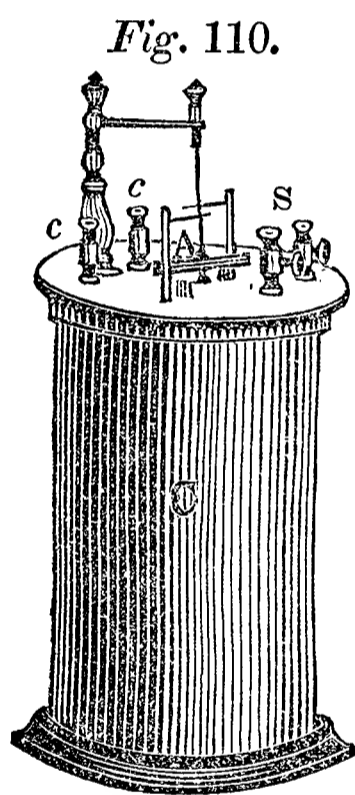

Fig. 110. This is enclosed in a cylindrical brass case C resting on a wooden base. The iron of the electro-magnet is not a solid bar but a bundle of wires; its poles pass up through the upper board, and an armature A is fitted to revolve above them. When the cups *c c* are connected with the battery, the current circulates through the inner coil, and passes through the springs which are seen in the figure bearing on the break-piece. The fine wire coil is connected with the cups seen at S, from which shocks may be obtained by handles as usual.

334. It might be expected that the brass cylinder C would exert a neutralizing action upon the shocks, as it is not divided longitudinally. But it is found that a metallic casing which thus entirely envelops a U magnet cannot act as a closed circuit, because each magnetic pole tends to induce a current in it in the opposite

direction to that which the other pole would excite; and consequently the secondaries of the coils are not in the least impaired by this arrangement.

335. If one of the battery wires is brought firmly in contact with one of the small pillars in which the silver springs are fastened, and the other put into one of the cups *c c*, so that the electro-magnet may be charged without the circuit being interrupted by the revolution of the armature, the fine wire coil will afford shocks perceptible to the tongue when the armature is made to revolve by drawing the finger over the axis. These shocks are due to the disturbance in the magnetic state of the electro-magnet by the approach and recession of the armature. They are very slight, because the inner coil affords a closed circuit for a secondary current whose neutralizing influence reduces the intensity of the one excited in the outer coil.

336. When an armature is brought suddenly up to the poles of a charged electro-magnet, an electric current is excited in its wires flowing against the battery current. When it is withdrawn, a current flows in the same direction as that from the battery. The phenomena belong to the same class as those described in § 272. The same effects are produced by bringing up a steel magnet or a second electro-magnet, if the attracting poles are presented to each other. When the repelling poles are presented, the two currents excited by their approach and recession flow in the reverse directions to those just described.

337. It has been mentioned in § 204 that these currents excited by motion present some of the most formidable obstacles to the employment of electro-magnetism

as a mechanical power. The independent motion of an electro-magnetic machine lessens the magnetizing power of the battery in proportion to its velocity, because the currents thus excited in the wires flow against the galvanic current; while the application of mechanical power to drive the machine against its own motion assists the battery current in producing magnetism.

338. PAGE'S COMPOUND MAGNET AND ELECTROTOME. In fig. 111 a double helix is seen attached horizontally to the base-board by two brass bands. In the centre a bundle of soft iron wires is permanently fixed. There

Fig. 111.

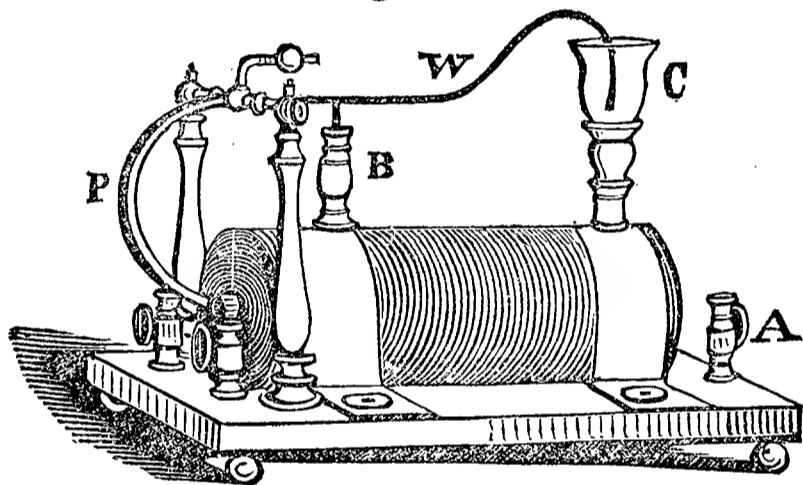

are two cups for the battery wires at one end of the stand: one of these is connected with the band which sustains the glass cup C for containing mercury. To the second cup is soldered one end of the coarse wire coil, the other extremity of which is connected with the band upon which the brass cup B, also intended to hold mercury, is fixed. A bent wire W, moving on a horizontal axis supported by two pillars, dips its ends into the two mercury cups. To the opposite side of the axis is attached a curved piece of iron P, the lower extremity of which approaches nearly the end of the enclosed bundle of iron wires.

339. When the connections are made with the battery, the current will traverse the wire W and the inner helix, causing the iron wires to become magnetic. They will now attract the end of the iron rod P; whose mo-

tion raises the bent wire out of the mercury in the cup C and breaks the circuit. This destroys the magnetism of the iron wires, and P ceases to be attracted. The wire W then falls back by its own weight, and the circuit is renewed. A thin slip of brass is soldered to the extremity of P, to prevent it from being retained by the electro-magnet after the rupture of the circuit.

340. In this manner a rapid vibration of the wire is produced, and brilliant sparks and deflagration of the mercury take place in the cup C. The proper balance of the vibrating apparatus is ensured by means of a brass ball screwing on a bent wire above the axis. The ends of the fine wire coil are connected with the other two cups on the stand, one of which is seen at A, whence shocks may be taken.

341. DISGUISED HELIX, FOR SPARKS AND SHOCKS. This consists of a metallic cylinder, fig. 112, enclosing a double helix and bundle of iron wires. It is divided

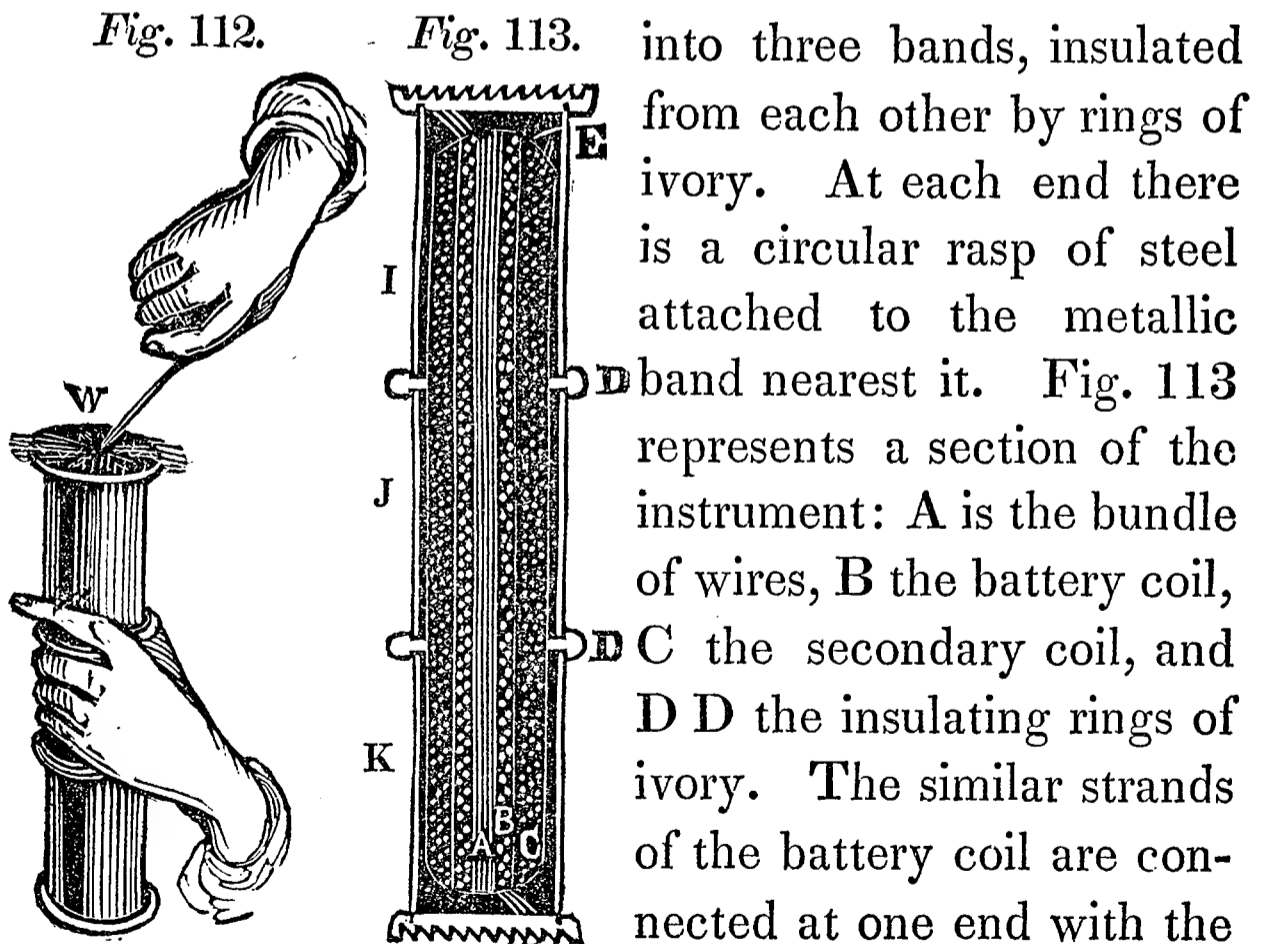

rasp fixed to the band K, and at the other end with the rasp and band I. One extremity of the fine wire coil is also connected at E with the band I, and of course through the battery coil with the band K. The other extremity is soldered to the insulated band J.

342. If now the instrument be grasped by the middle band, as in fig. 112, and one end being rested on the pole of a voltaic battery, the wire W from the other pole be drawn over the rasp, the circuit in the helix will be alternately completed and broken in rapid succession, and brilliant scintillations will be seen. So long as the operator confines his hand to the central band he will feel nothing, but if his fingers touch at the same time either of the outer bands, he will receive a strong shock through the hand from the fine wire coil. If the wire W is not insulated from the right hand by being wound with cotton, shocks will be felt in the arms when the other hand touches only the middle band.

343. MAGNETO-ELECTRIC APPARATUS FOR MEDICAL USE. The instrument most convenient, perhaps, for this

Fig. 114.

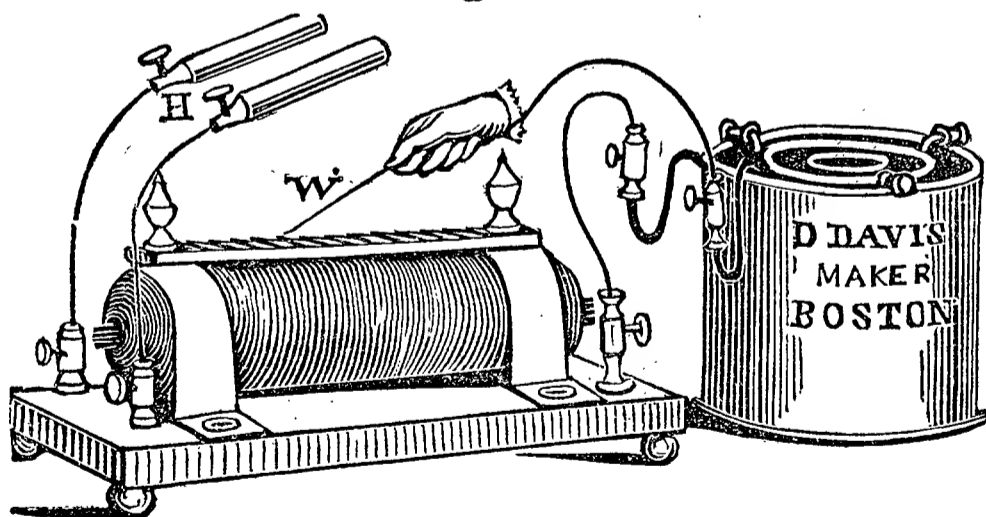

purpose is that represented in fig. 114. It consists of a double helix into which a bundle of iron wires can be inserted. The inner helix is composed of two or more

strands of coarse insulated copper wire. Their similar terminations at one end of the coil are soldered to a binding screw cup standing singly near one extremity of the base-board; their other ends are connected with both of the brass bands which confine the double helix to the stand, and by means of these with the steel rasp fixed above it. The outer helix is completely insulated from the other, and consists of fine insulated copper or iron wire. Its ends are connected with two binding screw cups at one extremity of the stand. In the figure, two metallic handles for shocks are seen at H, connected by wires with these cups.

344. The galvanic battery represented in the cut is the small cylindrical battery (§ 23), which is to be charged with a solution of blue vitriol, as directed in § 21. This will keep in good action for fifteen or thirty minutes at a time. When a more enduring power is wanted, it may be converted into a sustaining battery as described in § 241. This will maintain a steady current for several days in succession. The ends of the connecting wires should be kept clean and bright.

345. The battery being charged, unite one of its cups by means of a copper wire, with the cup belonging to the inner coil. Then draw over the steel rasp another wire W, whose end is fixed in the remaining cup of the battery. If the hollow of the helix is filled with iron wires, bright sparks will be seen as the wire leaves each tooth of the rasp, and strong shocks will be felt by grasping one of the handles seen at H in each hand. When the iron wires are withdrawn, the spark becomes faint and the shock feeble. These effects are produced by secondary currents excited in the coils in

consequence of the alternate closing and opening of the circuit of the galvanic current in the inner helix, by the movement of the wire *W* over the rasp: see § 236, 302.

346. The strength of the shock may be regulated at pleasure by varying the number of iron wires which are placed within the helix, or the distance which the bundle is allowed to enter it. The addition of a single wire produces a very perceptible increase in the shock, especially when only a few are already within. The intensity of the shock may be considerably increased by wetting the hands or other parts to which the handles are applied, especially with salt water. It may, on the contrary, be lessened in some degree by diminishing the extent of contact between the handles and the surface of the body. If, however, the current is powerful and the contact too slight, a disagreeable burning sensation will be experienced at the part touched by the metal.

347. The shocks may be passed through any portion of the body by placing the handles so as to include that part in the path of the secondary current; their intensity is greater when the handles are near each other. The influence does not extend beyond the direct course of the current unless the shocks are severe. When, however, one of the handles is placed directly over a large and tolerably superficial nerve, the shock will be felt not only in the parts intervening between the handles, but through those to which the ramifications of the nerve are distributed. Thus, if one handle be held in the right hand and the other pressed upon the inside of the left arm over the median nerve, the sensation will be experienced even to the ends of the fingers, attended by convulsive motions of their muscles. This is unques

tionably a physiological phenomenon, and not a consequence of the flow of the current below the position of the handle. The difference in the intensity of the shock in the two arms, described in § 313, may be observed with this instrument.

348. When it is inconvenient to break the circuit mechanically, some self-acting interruptor may be added to the arrangement last described. In fig. 115, Page's Revolving Armature (§ 182), which is probably the

Fig. 115.

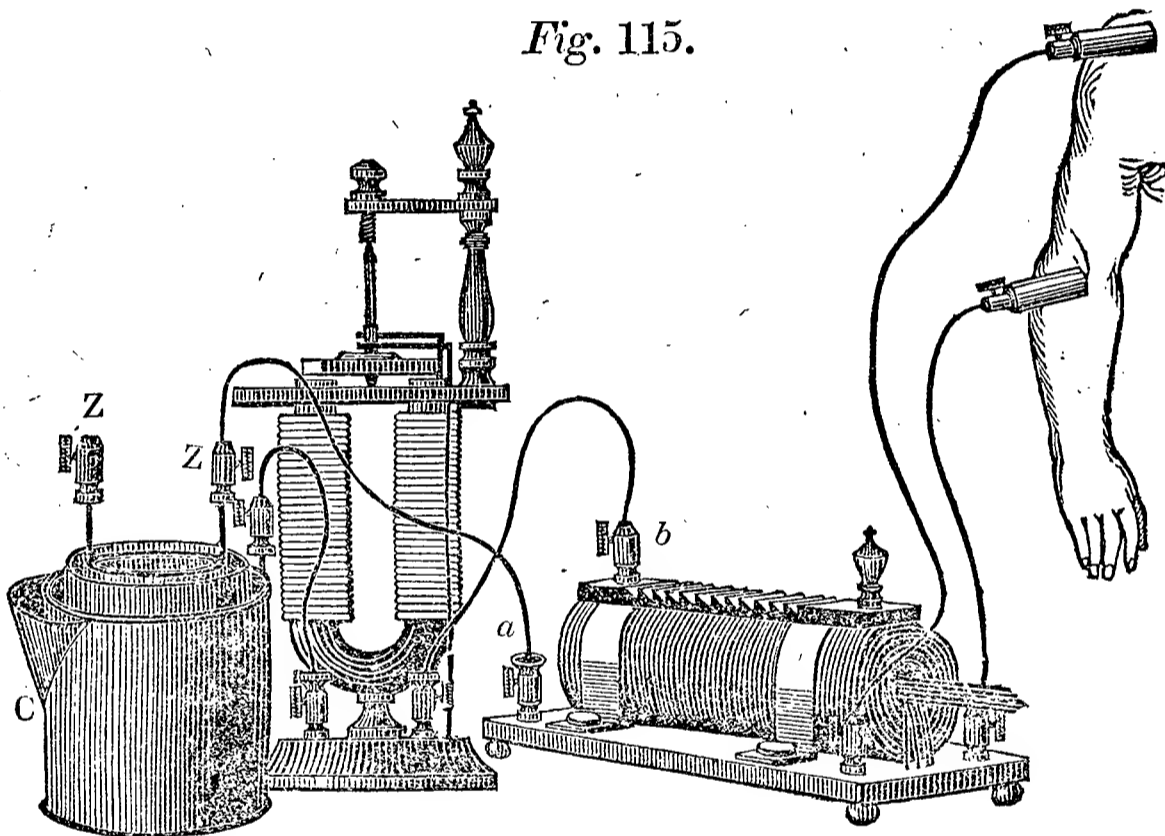

best instrument for the purpose, is seen in connection with the Double Helix. The galvanic current is transmitted through the two instruments in succession, by uniting one of the battery cups with one of those belonging to the Revolving Armature, whose other cup is connected with a cup *b* surmounting the Double Helix. The cup *a* on the stand is to be connected with the other plate of the battery.

349. A convenient form of the sustaining battery is shown in the figure. The copper vessel *C*, which is a

single cylinder provided with a bottom, has on one side a projecting mouth communicating by a number of perforations with the interior of the cylinder. This is designed to hold solid sulphate of copper for the purpose of keeping the solution saturated. The zinc cylinder is surmounted by two binding screw cups *Z Z*; its internal surface is painted or varnished, to protect it from the action of the solution. Between the zinc and copper plates is a cylinder of leather closed at the bottom. The management of this battery is the same as of the one described in § 241. The zinc plate might remain in the solution several days at a time without the battery materially declining in power, but it is better to remove it when not in actual use, as it would be needlessly corroded if kept constantly immersed.

350. When the connections are made as shown in the cut, the armature will rotate with great speed, breaking the circuit twice in each revolution. The shocks will consequently succeed each other very rapidly. In the figure, the handles are seen applied to the arm for the purpose of confining the shock to the parts between them. A single thickness of wetted linen or cotton cloth may be interposed between the metal and the skin, if desired, without producing much diminution in the shock.

351. If the apparatus is in use for half an hour only at a time, the battery represented in fig. 114 is better adapted than a sustaining one. When very powerful shocks are wanted, the Separable Helices (fig. 106) may be employed with a medium size or large cylindrical battery (§ 23), instead of the Double Helix; the Revolving Armature, seen in fig. 115, can be connected

with the inner coil. The shocks are stronger when one of the battery wires is drawn over the steel rasp than when the armature is included in the circuit. The galvanic battery may be dispensed with altogether by employing the Magneto-Electric Machine represented in fig. 101; the shock is regulated by the speed of the armature, but is never very powerful.

III. BY THE INFLUENCE OF THE EARTH.

352. Currents of electricity may be induced by the influence of terrestrial magnetism, but in consequence of the feebleness of the action it is not easy to render it sensible by the aid of wire coils alone. Deflections may, however, be obtained by connecting with a very delicate galvanometer a helix of coarse wire, such as is represented in fig. 48, or a flat spiral, fig. 49, and having placed its axis in the line of the *dip*, suddenly inverting it.

353. A very evident effect may be produced by employing the instrument represented in fig. 116. It

A Fig. 116.

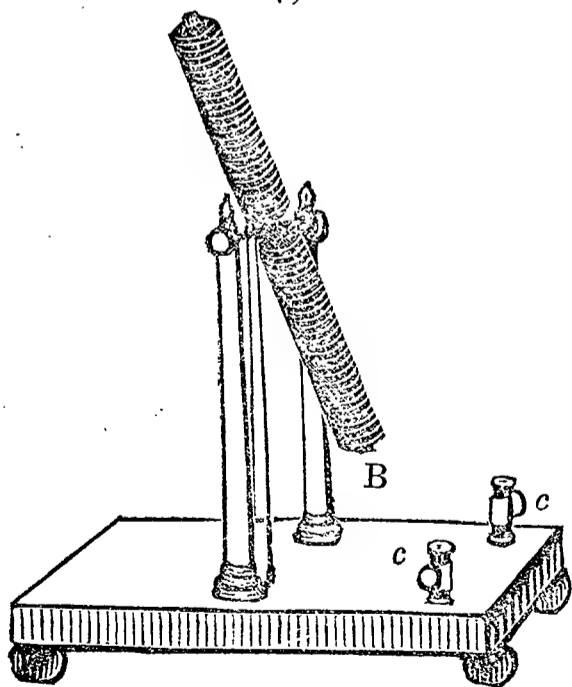

consists of a small rod of soft iron wound with wire, and fitted to revolve on a horizontal axis, which is provided with a pole-changer. Upon the segments of the pole-changer press two wires connected with the cups *c c*. The instrument is the same as that described in § 178, though for this purpose it is an advantage

to have several layers of wire wound upon the iron.

354. The instrument being placed in such a direction that the current may be reversed when the bar *A B* arrives at the line of the dip, connect the cups *c c* with those of a delicate galvanometer. Now on causing the bar to revolve by hand in one direction, each end of the iron will become alternately a north and a south pole, as has been explained in § 205, and a current of electricity, whose direction changes twice in each revolution, will be induced in the surrounding wire. The two currents are turned into one direction by the pole-changer, and the needle of the galvanometer will be strongly and steadily deflected. By reversing the motion of the bar, a deflection in the opposite direction will be obtained. With this instrument, the current is slightly augmented by the feeble one excited in the wire coil by the direct magneto-electric induction of the earth.

355. In this and all other cases where electricity produces motion, and motion reciprocally electricity, the motion must be the reverse of that which would be produced by a galvanic current flowing in a certain direction, in order to cause a current in the same direction to be induced; the same motion as that produced by the battery current exciting an opposite current. A similar reciprocal relation exists in the case of electricity and heat (see § 60), and of electricity and magnetism.

THE ELECTROTYPE PROCESS.

356. It has been stated in Exps. 55 and 56, that metallic solutions may be decomposed by the magneto-electric current, and the metals deposited on the negative wire with their proper characters. The same effect is produced by the galvanic current; the precipitation of copper on the negative plate of the sustaining battery has been noticed in § 243. When the deposited sheet of copper is stripped off, it is found to have copied with accuracy every scratch and irregularity on the surface of the battery plate.

357. The idea of applying this fact to practical purposes appears to have occurred nearly at the same time to Prof. Jacobi, of St. Petersburg, and to Mr. Spencer, of Liverpool. Jacobi's first results were published in 1838, and Mr. Spencer's the following year, but he had made some experiments as early as 1837. The principal uses to which the process has been applied are the copying of medals, engraved copper plates, plaster casts, &c., in copper: the name of *electrotypes* is given to the copies thus obtained, and sometimes the process or art itself is called simply The Electrotyle. This mode of working the metals promises to be of some value to the arts, though full success has as yet been attained with but a few of them.

358. The readiest mode of obtaining a copy of a coin or medal is to make a cast of it in the fusible metal, which consists of eight ounces of bismuth, five of tin, and three of lead to the pound: this alloy melts at or near the temperature of boiling water. A little of it being melted in a clean iron ladle, is poured on a flat board, and the oxide skimmed from its surface by a card. Then the medal, which may be fixed with wax to the end of a stick, is to be suddenly and forcibly pressed upon it. By one or two trials a mould may be made, presenting a perfect reverse of one face of the medal.

359. A clean copper wire is then soldered to the projecting edge of the mould by heating it in a lamp near one end, on which a little rosin should be put. When the wire is hot enough to melt the fusible metal, it is removed from the flame and its end pressed on the mould, which will adhere to it. The back of the mould and any other part which is not intended to receive a deposit are to be varnished once or twice with a solution of shellac or sealing-wax in alcohol. This will dry in a few minutes, and the mould is then ready for the solution.

360. A piece of thick rolled zinc may be soldered to the other end of the wire, which is bent in such a manner as to allow the mould to be immersed in a saturated solution of sulphate of copper, separated by some porous partition from a weak solution of sulphate of soda, in which the zinc is placed so as to be opposite the face of the mould. The solution of blue vitriol must be kept saturated by suspending in it a muslin bag containing some of the salt.

361. A better mode is to connect the wire attached to the mould with the zinc plate of a small sustaining battery such as is described in § 241 or 349. With the copper plate of the battery is connected a piece of copper which is to be immersed with the mould in an acidulated solution of blue vitriol contained in a glass or well-glazed earthenware vessel. No partition is used, but the piece of copper and the mould must not be allowed to touch each other. They should both be connected with the battery, and the copper placed in the solution, before the mould is introduced; in this way the chemical action, which would otherwise be exerted on the fusible metal, is prevented, and the deposition of copper commences immediately. Any air bubbles which adhere to the mould must be dispersed.

362. The solution is prepared by diluting a saturated one of blue vitriol with one half or one third of its bulk of a mixture of one part of sulphuric acid with eight of water by measure. As the copper is deposited on the mould, an equal quantity is dissolved off of the immersed plate, so that the original strength of the solution is maintained except for the loss of water by evaporation. The wire which connects the piece of copper with the battery must be defended from the solution in the same manner as the back of the mould, or it will soon be dissolved off.

363. During the solution of the positive plate a considerable quantity of black matter is left, which would injure the copy if allowed to fall on the mould. It is therefore best to place both in a vertical position, the face of the mould being opposite the piece of copper.

The solution must be stirred occasionally to keep its upper and lower parts of equal strength. If the copper is entirely dissolved before the deposit is sufficiently thick, a new piece may be soldered to the wire.

364. When the process is going on well, the deposited metal will be of a very light copper color. The rapidity of the deposition depends greatly upon the temperature; the process proceeds much faster in warm weather than in cold, and still more so if the solution be kept hot. A thickness of one tenth of an inch may require from three days to a week for its formation, when artificial heat is not used. When a sufficient thickness has been attained, the copy may generally be removed from the mould without difficulty, care being taken to cut away any copper which embraces the mould at the edges.

365. The cast will be found to be a perfectly accurate and sharp copy of the original; its surface is usually of a bright copper color, but sometimes it presents a brilliant silvery lustre. If it is discolored, it may be cleansed by immersion for a few moments in nitric acid and then washed with water. It may be bronzed by brushing it over with black lead immediately upon its removal from the solution, and having heated it moderately over a clear fire, rubbing it smartly with a brush, the slightest moisture being used at the same time, in order to remove the black lead.

366. A mould may be formed by placing the medal or coin itself in the solution and depositing copper upon it. A fine copper wire should be passed round the rim to connect it with the wire attached to the zinc plate of the battery; and as one face only can be advantageously

copied at a time, the other side should be coated with wax or varnish. The deposit is apt to adhere very firmly, sometimes so much so that its removal is impossible. This may be avoided by covering the medal with melted wax, and while warm wiping off the wax as far as possible with a cloth. Or advantage may be taken of the very thin film of air which adheres to bodies exposed to the atmosphere, by not placing the medal in the solution until the connections have been made with the battery, and the copper plate introduced. This film is soon removed by immersion in the liquid; and immediately by strong nitric acid, or a solution of potash, or by the application of heat.

367. The mould thus obtained may have a wire soldered to it and be placed in the solution like the fusible metal one; but after being heated by the soldering, and particularly if cleaned by nitric acid, it should be exposed to the atmosphere for twenty-four hours to gain a film of air, or be treated with wax like the original medal. It is so easy to take a copy by the fusible metal, by white wax, &c., that a valuable medal should never be trusted in the solution.

368. Every ounce of copper deposited requires the solution of somewhat more than an ounce of zinc from the zinc plate of the battery. Five or six electrotypes may be made at once, without increasing this expense, by arranging in succession several vessels, each containing a mould and a copper plate connected by a wire with the mould in the next one. The plates of copper and the moulds should all be nearly of the same size, and the solution should contain less blue vitriol and more

sulphuric acid than directed in § 362, particularly if the series extend beyond two or three. When the moulds are small, glass tumblers form the most convenient vessels. In this way several ounces of copper are obtained with but a slight increase in the quantity of blue vitriol required for working the battery, and a little more corrosion of the zinc plate.

369. An engraved copper plate may be copied by taking an impression on clean and bright sheet lead with a powerful press; or if the plate is small, it may be pressed by hand on the melted fusible metal. Or a mould may be made by depositing copper on the plate itself, but care must be taken to prevent adhesion both of the mould to the original, and of the copy to the mould, as directed in § 366 and 367. The duplicate thus obtained will furnish engravings which cannot be distinguished from those printed from the original plate, however elaborate the design and delicate the workmanship may be.

370. An engraving printed from an electrotype plate is given, as a specimen of the art, in the frontispiece to this Manual, in company with one from the original copper plate. No difference can be detected between the impressions except that arising from the greater or less quantity of ink left in the work, as occurs in different engravings printed from a single plate. This appears to be the most important application of the art yet made, as in cases where a large number of impressions are required, two or more plates have been obliged to be engraved, while now it is only necessary to engrave one, which will not be injured in the slightest degree by

taking copies from it. Steel plates may be copied by means of lead or fusible metal, but they must not themselves be placed in the solution.

371. Wood cuts may be copied by taking impressions from the blocks in the fusible metal; this has been done in the present work where it was desirable to introduce a single instrument in one figure and afterwards to show it in connection with some other. Thus fig. 63 is printed from an electrotype taken from the block of fig. 99. This is not, however, an important application, as the blocks can easily be stereotyped. The electrotypes may thus be obtained either with the design in relief, like wood blocks, or in intaglio, like copper plates.

372. Moulds are obtained from plaster medallions by placing them in hot water with the face upwards until the water (which should not be deep enough to reach the face) has thoroughly penetrated the plaster in every part; but none should remain on the surface. The cast being then removed and a slip of paper wrapped round the rim, melted white wax is immediately poured into the cup thus formed. Any air bubbles which are seen must be dispersed. The wax will be completely cold and hard in two or three hours, when it may be taken off of the cast with perfect facility, if the latter has been wetted sufficiently. The medallion will not be injured by the process except perhaps discolored.

373. It is now necessary to render the surface of the wax mould a conductor of electricity. This is done by giving it a coating of good black lead, which should be rubbed over its face with a soft brush until it acquires a shining black appearance; a very thin film is sufficient.

A copper wire is then to be heated in a lamp, and its end pressed upon the edge of the mould, when it will become imbedded in the wax. Communication between the wire and the face of the mould is to be ensured by rubbing a little black lead on the parts around the wire. Great differences exist between one sample and another of plumbago, some being very poor conductors. Perhaps the best test of good black lead is its caking together and adhering when pressed between the thumb and finger.

374. The mould when thus prepared may be put into the solution, care being taken to remove air bubbles. The deposit commences upon the wire and extends gradually over the black leaded portions. It is better that the copper connected with the copper plate of the battery and placed in the solution should be a wire rather than a large piece, until the deposit has extended some distance over the black lead. When the copy is taken from the mould its surface will usually be found discolored, though if the layer of black lead was thin it may be perfectly bright. The mould may be employed again, if a new coating of black lead is given to it; the fusible metal moulds can also be used several times if uninjured.

375 Seals may be copied by a very simple process. They are to be covered with a thin film of black lead rubbed on with a hard brush. If this does not adhere readily, the seal may be very slightly wet with alcohol, care being taken not to roughen the surface. A wire is then melted into the sealing-wax and the seal placed in the solution. The operation is similar in all respects to that required for the white wax moulds.

376. The copper may be deposited in three different states; as a black, spongy or pulverulent mass, or in a crystalline form, or lastly, as a ductile and malleable plate. The black deposit is obtained when the quantity of electricity is too great in relation to the strength of the solution. This can be remedied in several ways; as by using a weaker charge for the battery, or by increasing the proportion of blue vitriol and lessening that of the sulphuric acid in the solution. Or the mould may be removed to a greater distance from the opposed plate of copper, or lastly, the size of this plate may be diminished.

377. The crystalline deposit is obtained when the quantity of electricity is too small in proportion to the strength of the solution. In this case, the crystals are minute and the copper is very brittle. The quantity of electricity which passes through the solution may be increased by adopting the opposite measures to those just indicated for avoiding the black deposit.

378. Another variety of the crystalline deposit occurs when the quantity of electricity is large, and at the same time the solution is very strong and but slightly acidulated, especially if the mould is small and the opposed copper plate of considerable size. The deposited metal is then very hard and is composed of large crystals.

379. For most purposes the metal is wanted in a ductile and malleable state. To effect this, both of the extremes above indicated must be avoided. It is better that the metal should be somewhat hard and elastic rather than very soft and flexible. When the current is of proper strength, the outer surface of the deposit

remains nearly smooth until it attains a considerable thickness, if the solution is kept of uniform strength throughout by stirring it up occasionally. The soft, flexible deposit is obtained in the greatest perfection when a current is maintained of such a power that hydrogen is just on the point of evolution from the negative plate or mould; if bubbles of the gas are seen to rise from it, the current is too strong, and the deposit will partake more or less of the spongy character.

380. When the copper plate which is opposed to the mould in the solution is coated with wax, in which lines are drawn reaching the metal, it will be etched by the acid, and may afterwards be printed from like a plate etched in the usual way by nitric acid. The sulphuric acid dissolves the copper just in proportion to the quantity of electricity passing. The negative plate should be of the same size as the positive one, and be placed parallel to it in the solution.

381. The action which takes place is as follows: the sulphate of copper and the water of the solution are both decomposed; sulphuric acid and oxygen are determined towards the plate connected with the positive pole of the battery, and oxide of copper and hydrogen towards the other. The oxygen and the acid combine with the positive copper plate, again forming blue vitriol; while at the negative plate, the hydrogen forms water with the oxygen of the oxide of copper, and the pure metal is deposited.

382. The precipitation of the other metals is regulated by the same laws, but it is more difficult to obtain them in a useful state. Those which it is most impor-

tant to be able to work in this way are gold, silver, and platinum. The solutions of all the noble metals are good conductors of electricity, and very easily decomposed; hence there is a great tendency to the evolution of hydrogen and the formation of a black deposit.

383. A battery consisting of three or four pairs of plates of small size and very weakly charged is best adapted for the noble metals, as the current should be of considerable intensity but small quantity. We have seen in Exp. 56 that gold is readily deposited with its proper characters by the magneto-electric current. The face of a medal may be made of gold or silver by depositing a thin layer of either of these metals, and afterwards filling up the back with copper; but the face of the mould must be itself of gold or silver. A more important application is to cover the oxidizable metals with a thin and permanent coating of the noble ones.

384. Silver, copper, and brass may be gilt by employing a very dilute solution of the nitro-muriate of gold. The article should be previously cleaned by diluted nitric acid or by a solution of potash, and after washing in water, immediately connected with the zinc end of the battery series and placed in the solution. Its immersion must be the last thing needed to complete the circuit, or the gold will not adhere firmly. The smoother and larger its surface, the more favorably the deposit will take place upon it. A very fine gold or platinum wire is to be used as a positive pole, being immersed to a greater or less depth in the solution. Whenever during the process the deposit becomes

blackened, the negative plate should be taken out and rubbed with a little whiting.

385. When the surface is completely covered with gold, the strength of the solution may be increased. The coating can be made of any desired thickness, and may be limited to any portion of the article, by covering the remaining parts with wax, or varnishing them. Silver spoons may be gilded, after being cleaned as above, by pressing a wire connected with the zinc pole of the battery upon the handle by a small forceps and then immersing the rest of the spoon in the solution. In gilding copper, the point only of the positive wire must be immersed, and the solution must be very weak, or the deposited gold will be of a red color, in consequence of the solution of some of the copper.

386. Silver may be deposited on copper by employing a solution of the sulphate or acetate of silver, but it is difficult to prevent the formation of the black powder. The article should be rubbed with whiting before being placed in the solution, and frequently during the process. A very fine silver wire is used as a positive pole.

387. Platinum may be thrown down on silver, copper, &c., from its solution in nitro-muriatic acid, but the process is difficult. The solution must be very weak, and the object to be coated smooth and well cleansed by potash. The positive pole should be a fine platinum wire. Any powder which may be deposited on the article is removed by rubbing it occasionally with whiting. The coating thus obtained has almost precisely the color of polished steel.

I N D E X .

	Section.
Ampere's Rotating Battery, - - - - -	148
Animal electricity, - - - - -	61
Arch of flame between charcoal points, - - - - -	32
" " revolution of, - - - - -	167
Armature, - - - - -	9
" and magnet, action between, - - - - -	110
" Magneto-Electric, - - - - -	274
Artificial magnets, - - - - -	2
Astatic needles, - - - - -	81, 82
Attraction of currents, shown by frictional electricity, - - - - -	219
Attractions and repulsions of currents, - - - - -	213-222
" " magnetic poles, - - - - -	62-64
Aurora borealis affects magnetic needle, - - - - -	103
Bar magnet, - - - - -	7
Barlow's Revolving Spur-Wheel, - - - - -	156
Batteries, compound galvanic, - - - - -	30-33
" thermo-electric, - - - - -	53-58
" single, how connected, - - - - -	29
Battery, cylindrical galvanic, - - - - -	20
" magnetic, - - - - -	8
" sustaining, - - - - -	241-243, 349
Black lead, used in the electrotype process, - - - - -	373
Calorimeters, - - - - -	17
Carbon, kind used in thermo-electric experiments, - - - - -	44
Charcoal points, arch of flame between, - - - - -	32
Coins and medals, mode of copying, - - - - -	358-368
Cold produced by galvanic current, - - - - -	59, 60
Compound bar magnet, - - - - -	7
" horse-shoe magnet, - - - - -	8
" Magnet and Electrotome, Page's, - - - - -	338
Conducting power of metals, - - - - -	25
Connecting wires, - - - - -	25, 35
Contact Breaker, - - - - -	229

	Section.
Copper, deposited in three different states, - - -	376-379
" plates, how copied, - - - - -	369, 370
Cylindrical battery, - - - - -	20
De la Rive's Ring, - - - - -	130
Decomposing Cell, - - - - -	288
Decomposition produced by Magneto-Electric Machine,	286-293
Deflection of galvanometer needle, - - - - -	46
Difference of shock in the arms, - - - - -	284, 313
Dip of the magnetic needle, - - - - -	94
Dipping needle, - - - - -	92, 93
" " deflected by electric current, - - -	77
Directive tendency of magnet, defined, - - - - -	69
Disguised Helix, for sparks and shocks, - - - - -	341
Double " - - - - -	343
" " Page's, - - - - -	129
" " and Electrotome, - - - - -	245
" " " Revolving Armature, - - - - -	348
" Revolving Magnet, - - - - -	175-177
" Spur-Wheel, - - - - -	160
" Thermo-Electric Revolving Arch, - - - - -	203
" Vibrating Magic Circle, - - - - -	155
Earth, induction of electricity by the - - - - -	252-254
" " magnetism by the - - - - -	205-208
Electric current, tangential action of the - - - - -	78, 79
" currents, mutual attractions and repulsions of,	213-219
Electricity, animal, - - - - -	61
" frictional or mechanical, - - - - -	12
" galvanic or voltaic, - - - - -	14-35
" induced by movement of armature, - - - - -	272, 336
" " " " magnet near a wire, - - - - -	267
" " " " " " flat spiral, - - - - -	268
" " " " " " wire near a magnet, - - - - -	269
" " " temporary magnetism of iron, - - - - -	270, 271
" " " the magnetism of the earth, - - - - -	352, 353
" obtained from steam, - - - - -	13
Electrodes, - - - - -	15
Electro-Dynamic Revolving Ring, - - - - -	220
Electro-Dynamics and Electro-Statics, phenomena of,	210-224
" Magnet, attracts its armature at a little distance,	134
" " compound, - - - - -	188
" " in frame, - - - - -	133
" " retains its power while armature is applied,	133
" " sustains iron when magnetism is lost, - - - - -	327
" " with three poles, - - - - -	135
" Magnetic induction, definition of, - - - - -	116

	Section.
Electro-Magnetic Seasons Machine, - - - - -	174
“ Magnets, - - - - -	131
“ “ Prof. Henry’s, - - - - -	132
Electro-Magnetism as a motive power, - - - - -	204, 337
“ “ definition of, - - - - -	1
Electrotype medals, - - - - -	358-368
“ “ bronzed and cleansed, - - - - -	365
“ “ several made at once, - - - - -	368
“ “ time required for making, - - - - -	364
“ “ with gold or silver faces, - - - - -	383
“ origin of the, - - - - -	356, 357
“ process, nature of the - - - - -	381
Engraved copper plates, how copied, - - - - -	369, 370
“ steel “ “ “ - - - - -	370
Etching by the galvanic battery, - - - - -	380
Explanations and Definitions, - - - - -	1-11
Filings sustained by wire conveying a current, - - - - -	117
Flat coil of fine wire, - - - - -	240
“ Spiral, - - - - -	123
“ “ exerts slight magnetizing power on outside, - - - - -	124
Fracture of magnets, - - - - -	115
Frictional electricity, - - - - -	12
Fusible metal, used in the electrotype process, - - - - -	358
Galvanic batteries, cylindrical, - - - - -	20, 23
“ “ directions for using, - - - - -	21, 22
“ “ exciting liquid used in, - - - - -	21
“ “ compound, - - - - -	30-33
“ “ sustaining, - - - - -	241-243, 349
“ current produces heat and cold, - - - - -	59, 60
“ “ direction of, - - - - -	14
“ “ quantity and intensity of, - - - - -	17-19
“ etching, - - - - -	380
Galvanometer deflected by magneto-electric current, - - - - -	278, 294
“ “ secondary current, - - - - -	234, 305
“ measures quantity but not intensity, - - - - -	88
“ Upright, - - - - -	86
“ with astatic needle, - - - - -	87
Galvanometers, - - - - -	83-88
German silver, composition of - - - - -	45
Gilding by the electrotype process, - - - - -	384, 385
Gold leaf Electroscope affected by magneto-electricity, - - - - -	325
“ Galvanoscope, - - - - -	153
Heating of metallic wires by electricity, - - - - -	24-28
Heliacal Ring or Magic Circle, - - - - -	126-18
Helix, exerts no perceptible magnetizing power on outside, - - - - -	122

	Section.
Helix, Magnetizing, - - - - -	235
“ on stand, - - - - -	120
Horizontal Revolving Armatures, - - - - -	185
Horse-shoe magnet, - - - - -	8
Induced currents from frictional electricity, - - - - -	264
“ “ table of - - - - -	263
Induction of a current on itself, - - - - -	225-233
“ electricity, - - - - -	3
“ magnetism, - - - - -	3
“ secondaries at a distance, - - - - -	250
Inductive action of magnet not affected by interposed bodies, - - - - -	114
Initial and terminal secondaries, - - - - -	236
“ “ tertiaries, - - - - -	260
“ secondary of lower intensity than terminal, - - - - -	239
Instruments for illustrating the magnetism of the earth, - - - - -	99, 101
Instrument for showing the mutual action of currents, - - - - -	214
“ “ production of cold and heat, - - - - -	60
Intensity and quantity in electricity, - - - - -	17, 18
Iron, cause of its being attracted by a magnet, - - - - -	106
“ filings, arrangement of round wire conveying current, - - - - -	117
“ “ “ the poles of a magnet, - - - - -	73, 74
“ increases sparks and shocks, - - - - -	302, 304
“ small piece of, scarcely attracted by magnet, - - - - -	65
“ wires superior to bar in increasing sparks and shocks, - - - - -	304, 307
Leyden jar charged with magneto-electricity, - - - - -	325
Line of no variation, - - - - -	95
Loadstones, - - - - -	2
Magic Circle or Helical Ring, - - - - -	126-128
Magnet, - - - - -	2
“ artificial, - - - - -	2
“ bar, - - - - -	7
“ horse-shoe or U, - - - - -	8
“ natural, - - - - -	2
“ permanent, - - - - -	6
“ revolving by the earth's action, - - - - -	178
“ “ round a conducting wire, - - - - -	140
“ “ “ its own axis, - - - - -	141
Magnetic attractions and repulsions, - - - - -	62-65
“ curves, - - - - -	74
“ needle, - - - - -	10
“ “ half brass, - - - - -	80
“ observations, - - - - -	104
“ poles, - - - - -	5
“ “ of the earth, - - - - -	95, 102
“ toys, - - - - -	66

	Section.
Magnetism, definition of	1
“ of the earth, theories concerning,	96, 97
“ induction of	3
“ “ by the earth,	205, 206
“ “ “ “ how aided,	207
“ “ “ “ magneto-electric current,	295
Magnetism, induction of, by the secondary currents,	234
“ probably due to electric currents,	218
“ modes of communicating,	108, 208
“ “ “ by electro-magnets,	136, 137
“ “ removing,	138, 209
Magnetizing Helix,	235
Magneto-Electric Apparatus for medical use,	343-351
“ Armature,	274
“ current, different modes of exciting,	266
“ “ quantity and intensity of,	296
“ Machine for decompositions,	282
“ “ shocks,	279
Magneto-Electricity, definition of,	1
Magnets, fracture of,	115
“ modes of charging,	108, 208
“ “ “ by an electro-magnet,	136, 137
Marsh's Vibrating Wire,	150
Medals copied by the electrotype process,	358-368
Medical use, apparatus for,	343-351
Metallic solutions decomposed by magneto-electricity,	292, 293
Metals, precipitation of by galvanism,	382
Motions produced by attraction of armature,	182-193
“ “ changing poles of electro-magnet,	168-191
“ “ magnets and conductors,	139-167
Natural magnets,	2
Needle, astatic,	81, 82
“ dipping,	92, 93
“ floating,	67
“ horizontal magnetic,	90, 91
“ magnetic,	10
Ørsted's experiment,	75
Optical illusions, transient duration of electric light,	158, 170, 321
Oxygen and hydrogen obtained separately from water,	289
Page's Compound Magnet and Electrotome,	338
“ Double Helix,	129
“ Reciprocating Engine,	129
“ Revolving Armature,	182
“ “ “ for shocks,	333

	Section.
Page's Revolving Magnet, - - - - -	171
“ “ “ as a magneto-electric machine, - - - - -	297
“ “ Ring, - - - - -	162
“ Rotating Multiplier, - - - - -	165
Percussion, development of magnetism by - - - - -	207, 208
Permanent magnets, - - - - -	6
Plaster casts copied by the electrotype, - - - - -	372-374
Platinating by the electrotype process, - - - - -	367
Plating by the electrotype, - - - - -	386
Platinum, a poor conductor of electricity, - - - - -	25
Pole-changer, Dr. Page's, - - - - -	162
Poles of a galvanic battery, - - - - -	14, 15
“ “ magnet, - - - - -	4, 5
“ “ “ situated near its extremities, - - - - -	113
“ magnetic, of the earth, - - - - -	95, 102
Powder Cup, - - - - -	26
Primary magneto-electric current, effects produced by, - - - - -	285-295
Properties of the magnet, little known till recently, - - - - -	11, 89
Quantity and intensity in electricity, - - - - -	17, 18
“ “ of the magneto-electric current, - - - - -	296
“ “ “ thermo-electric current, - - - - -	52
Reciprocating Bell Engine, - - - - -	192
Repulsion of successive portions of current, - - - - -	223
Revolution of arch of electric flame, - - - - -	167
Revolving Armature, - - - - -	182
“ “ for shocks, - - - - -	333
“ Cylinder, - - - - -	145
“ Disc, - - - - -	161
“ Rectangle, - - - - -	164
“ Ring, - - - - -	162
“ “ and Magnet, - - - - -	166
“ “ Electro-dynamic, - - - - -	220
“ Spur-Wheel, - - - - -	156
“ Wire Frame, - - - - -	143
Ritchie's Revolving Magnet, - - - - -	168
Rolling Armature, - - - - -	68
Rotating Battery, - - - - -	148
“ Bell Engine, - - - - -	172
“ Multiplier, - - - - -	165
Rule for determining polarity produced by straight current, - - - - -	119
“ “ “ “ current in helix, - - - - -	121
Salts decomposed by the Magneto-Electric Machine, - - - - -	291, 292
Seals copied by the electrotype, - - - - -	375
Secondary currents, - - - - -	234-256
“ “ from a primary intensity current, - - - - -	248

	Section.
Secondary currents from wire helices, - - - - -	244
" " induced at a distance, - - - - -	250
" " " in different positions of coils, - - - - -	251
" " produced by motion, - - - - -	254, 255
Separable Helices, - - - - -	301
" " and Electrotome, - - - - -	318
" " " Revolving Armature, - - - - -	329
Shock from galvanic battery due to a secondary current, - - - - -	249
" primary coil, - - - - -	303
" " magneto-electric current, - - - - -	277, 285
Shock given to several persons at once, - - - - -	312
" strength of, depends upon extent of contact, - - - - -	310, 311
" " regulated, - - - - -	250, 251, 304, 346
" strongest from coil surrounding middle of helix, - - - - -	316
" cannot be obtained from helix in an iron tube, - - - - -	328
" difference of in arms, - - - - -	284, 313
" from secondary of fine wire coil, - - - - -	238
" passed through any part of the body, - - - - -	347
Shocks produce numbness when very rapid, - - - - -	330
" produced by movement of armature, - - - - -	335
" taken from water, - - - - -	314
Silvering by the electrotype process, - - - - -	386
Spark from long wire and helix, - - - - -	225, 226
" " secondary helix, - - - - -	322
" and shock from flat spiral, - - - - -	228, 231
" " " fine wire coil, with compound battery, - - - - -	232
" " " long wires and spirals, cause of, - - - - -	233
" " " Thermo-Electric Battery, - - - - -	326
" " " wire coils increased by iron, - - - - -	302, 304
" " reduction of - - - - -	252, 253, 304-308
" " why reduced, - - - - -	256, 261, 305, 306
Star Plate, - - - - -	111
Sturgeon's Revolving Disc, - - - - -	161
Successive induction of magnetism, - - - - -	112
Sustaining Battery, - - - - -	241, 349
" " action within, - - - - -	242
" " precipitation of copper in, - - - - -	243
Tangential action of electric current, - - - - -	78, 79
Terminal secondary of higher intensity than initial, - - - - -	239
Tertiary currents, - - - - -	257-260
" " obtained from wire helices, - - - - -	259
Thermo-Electric Arch rotating between poles of U magnet, - - - - -	200
" Batteries, - - - - -	53-58
" " sparks and shocks from, - - - - -	326
" combinations, - - - - -	43-51

	Section.
Thermo-Electric combinations, table of, - - - -	47
“ current, cause of, - - - -	39
“ “ direction of, - - - -	42
“ “ excited in a single metal, -	37, 38
“ “ quantity and intensity of, -	52
“ “ reversed in some cases, -	48-51
“ Revolving Arch, - - - -	194
“ “ “ on U magnet, - - - -	197
“ “ Wire Frames, - - - -	199
Thermo-Electricity, discovery of, - - - -	36
U magnet, - - - - -	8
Upright Reciprocating Engine, - - - -	190, 191
Variation of the magnetic needle, - - - -	98
“ “ “ “ how found, - - - -	100
Vibrating Magic Circle, - - - -	154
“ Wire, - - - - -	150
Voltaic batteries, - - - - -	20-34
“ Gas Pistol, - - - - -	27
“ electricity, - - - - -	14-35
Water decomposed by the magneto-electric current, 323, 324	
“ “ “ Magneto-Electric Machine, 286-290	
White wax used in the electrotype process, - - - -	372
Wire conveying current does not attract light bodies, -	224
“ for conveying electric currents, - - - -	35
Wood cuts copied by the electrotype, - - - -	371
Y Armature, - - - - -	111

DANIEL DAVIS, JR.

NO. 11 CORNHILL, BOSTON, MASS.

MANUFACTURES AND KEEPS FOR SALE

Instruments to illustrate the Principles of

GALVANISM,
ELECTRO-DYNAMICS,
MAGNETISM,

ELECTRO-MAGNETISM,
MAGNETO-ELECTRICITY,
THERMO-ELECTRICITY.

 **IMPROVED MEDICAL APPARATUS.**

ELECTROTYPE APPARATUS MADE TO ORDER.

Figure.*		Price.
1.	Case of Bar Magnets,	from \$2.50 to 5.00
2.	Horse-shoe or U Magnet,12½ to .50
3.	Compound Horse-shoe Magnet,	\$3 to 10.00
4.	Magnetic Needle on brass stand,75 to 1.00
5.	Rod for collecting Electricity from the Steam Engine,	5.00
6.	Plates of zinc and copper for elementary experiments,25 to .75
7.	Cylindrical Battery, small, \$2, medium, \$5, large,	7.00
8.	Powder Cup,	from .25 to .50
9.	Voltaic Gas Pistol,	from 1.50 to 3.00
10.	Galvanic Battery, 25 pairs of double plates,	\$20 to 25.00
	Galvanic Battery, 100 pairs of double plates,	85.00
12.	Thermo-Electric pairs, of various metals,	from .12½ to .50
13.	Galvanometers, for Thermo-Electric and other experiments, 3 to	8.00
14.	Thermo-Electric Battery, 10 pairs,	1. to 2.00
15.	“ “ “ “ 60 large plates,	\$15. to 25.00
16.	Apparatus for the production of heat and cold by the galvanic current,	3.00
17.	Bar Magnet and Magnetic Needle,	1.00
19.	Oblong and circular pieces of iron, for Exp. 5,12
	Set of Magnetic Toys, swans, ships, fishes, &c.,	2.00
20.	Rolling Armature and Magnet,	\$3 to 5.00
21.	Bar Magnet and iron bar,	1.25
24.	Iron Filings, for experiments, per box,	.25
27.	Astatic Needle, on stand,	from 1 to 2.00
29.	Galvanometer, for Ersted's experiments,	3.50 to 5.00
30.	“ “ “ “ on tripod stand, with leveling screws,	6.00
31.	Upright Galvanometer, on tripod stand,	from 5 to 6.00
33.	Dipping Needle, with universal joint,	3 to 6.00
34.	Terrestrial Globe, with bar magnet within it,	3 to 5.00
35.	Instrument, for explaining variation and theory of magnetism, 4 to	8.00
37.	Terrestrial Globe, with coil, needle, &c.,	3 to 6.00
41.	Y Armature,50
42.	Circular iron plate,50 to .75
43.	Star Plate,50 to .75
46.	Bar Magnets, for breaking, &c.	each, .10
47.	Galvanic Battery, large size,	\$5 to 7.00
48.	Helix, on stand, with iron rod,	from 1 to 3.00

* The figures in the first column refer to Davis's Manual of Magnetism.

	Price.
49. Flat Spiral,	1.50 to 10.00
50. Helical Ring and Armatures,	2.50 to 3.00
51. " " " " ball and socket joints,	\$5 to 8.00
52. De la Rive's Ring,	1.00
53. Small Electro-Magnets,50 to 1.50
54. Electro-Magnet, in frame,	\$5, \$10, and 30.00
55. " " with three poles,	3.00
56. " " for charging magnets,	from .75 to 1.50
57. Magnet revolving round conducting wire,	brass frame, 6.00
58. " " " its own axis,	from \$5 to 6.00
59. Double Revolving Wire Frame, brass stand, leveling screws,	8.00
60. " " Cylinders, " "	5 to 6.00
61. " Rotating Batteries on steel magnet,	5 to 8.00
62. Marsh's Vibrating Wire, without magnet, 1.50, with magnet,	5.00
63. Gold leaf Galvanoscope, brass stand,	4 to 6.00
64. Vibrating Magic Circle,	4 to 6.00
65. Double Vibrating Magic Circle,	5 to 7.00
66. Barlow's Revolving Spur-Wheel.	3.50 to 5.00
67. Page's Revolving Ring,	from 5 to 6.00
69. Revolving Rectangle,	5 to 6.00
70. " Ring and Magnet,	8 to 10.00
Ritchie's Revolving " " see \$168,	4 to 6.00
71. Page's " "	5 to 6.00
72. Rotating Bell Engine,	10 to 12.00
73. Electro-Magnetic Seasons Machine,	12 to 15.00
74. Double Revolving Magnet,	6 to 10.00
76. Magnet revolving by the Earth's action.	3 to 5.00
77. Page's Revolving Armature,	3 to 4.00
78. Horizontal do. Armatures,	4 to 6.00
79. Page's Reciprocating Engine,	10 to 12.00
80. Upright do. do.	10 to 20.00
81. do. do. do. round base,	15.00
82. Reciprocating Bell Engine,	18 to 20.00
83. Thermo-Electric Revolving Arch,	1.50 to 2.00
84. " " " " on U magnet,	3 to 4.00
85. Double Thermo-Electric Wire Frames,	5 to 8.00
86. Thermo-Electric Arch rotating between poles of U magnet,	3 to 5.00
87. Double " Revolving Arch,	4 to 5.00
88. Bar of soft iron and small Magnetic Needle,	1 to 2.00
89. Steel Bar, unmagnetized,25 to .50
91. Movable Wires, for showing attraction and repulsion,	3 to 4.00
92. Electro-Dynamic Revolving Ring,	5 to 8.00
93. Electrotome, or Contact Breaker,	5 to 8.00
94. Magnetizing Helix, for induced currents,	3.00
95. Flat Spiral and rasp,	5 to 8.00
96. Double Helix and Electrotome,	\$20 to 25.00
97. Fine Wire Spiral,	8 to 10.00
99. Gold Leaf Galvanoscope, with magnet and coil,	9.00
100. Magneto-Electric Armature, without magnet, \$6, with do.,	12.00
101. " " Machine for shocks,	30.00
102. " " " for decompositions,	from \$30 to 35.00
103. Decomposing Cell,	3 to 5.00
104. U Tube for decompositions,50 to 1.00
105. Page's Revolving Magnet and Galvanometer,	9.00
106. Separable Helices, with handles for shocks,	\$12 to 18.00
108. " Helices and Electrotome,	20 to 25.00
109. " " and Revolving Armature,	15 to 20.00
110. Page's Revolving Armature for shocks,	5 to 6.00
111. " Compound Magnet and Electrotome,	8 to 12.00
112. Disguised Helix for sparks and shocks,	6 to 8.00
114. Magneto-Electric Apparatus for medical use,	from \$10 to 12.00
115. Magneto-Electric Apparatus for medical use, with Page's Revolving Armature,	15.00
Fusible metal, for the electrotome,	per lb. .65

A

CATALOGUE

OF

PHILOSOPHICAL, ASTRONOMICAL, CHEMICAL AND
ELECTRICAL

APPARATUS,

IMPORTED, MANUFACTURED AND SOLD BY

JOSEPH M. WIGHTMAN,

Successor to Claxton & Wightman,

NO. 33 CORNHILL, CORNER OF FRANKLIN AVENUE, BOSTON.

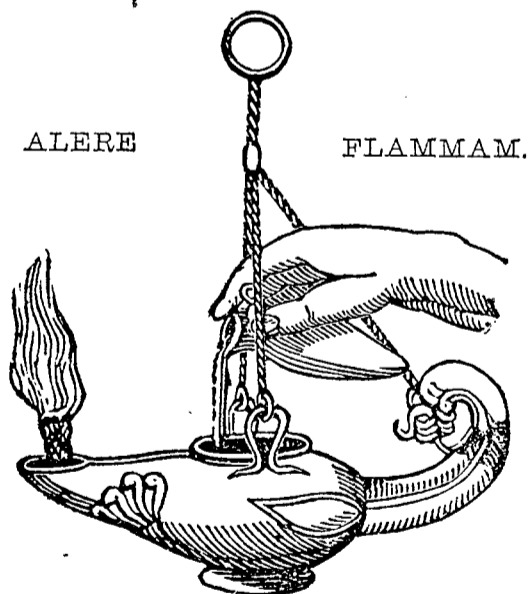

BOSTON:

PRINTED BY SAMUEL N. DICKINSON.

.....

1842.

WIGGHTMAN'S
CATALOGUE
OF
PHILOSOPHICAL INSTRUMENTS.

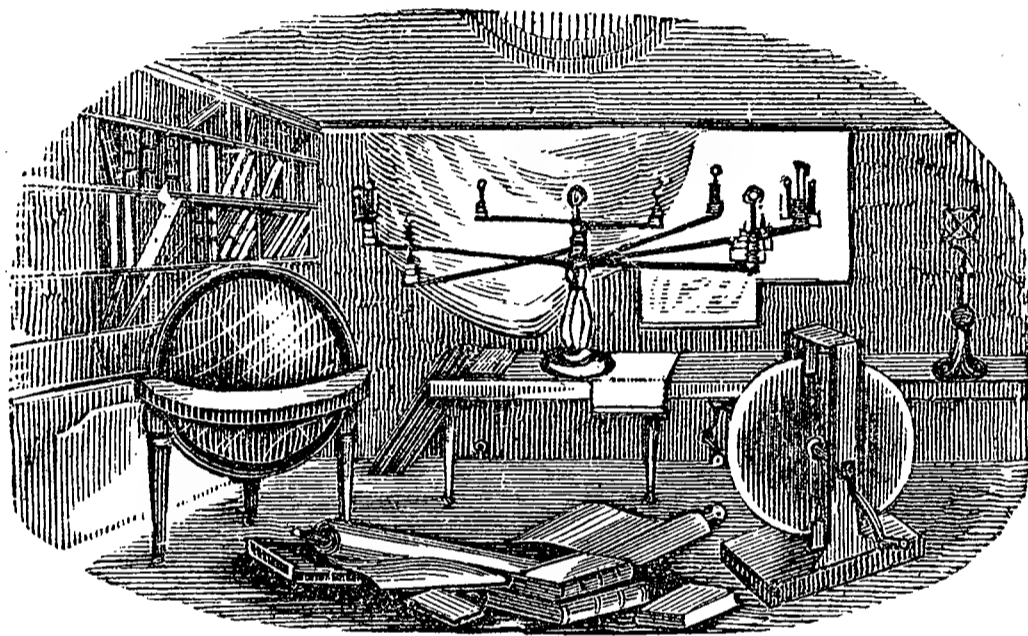

THE present Catalogue of Apparatus will be found more full, and the Instruments much improved in form, finish and construction, since the issue of my last catalogue, in 1838, which is due to the encouragement of our friends and customers. Our principles of business, as expressed in former catalogues, "that orders by *letter* will be as faithfully and conscientiously executed as if the purchaser were *present*," has received the confidence and approval of our friends heretofore, and their orders can be made up from our list with full confidence that the prices are the *same to all*.

I have much pleasure in calling attention to the extensive variety of Air Pumps and Sets of Apparatus recently added. Of the advantages of our system of Single Barrel Air Pumps, with Simple Lever, I need scarcely mention, as they are now too favorably known and extensively used to require it. Public opinion has so far sanctioned our views expressed in 1834, "that

the Simple Lever Pump would supersede all other forms," that other manufacturers have been obliged to adopt modifications of the Simple Lever, and abandon the geered circular motion.

For a summary of the peculiar improvements combined in my new Air Pumps, I beg to refer to the catalogue, and to the annexed report of the judges at the Exhibition of the Mechanic Charitable Association, for 1841, awarding their

GOLD MEDAL

for my improvements in Air Pumps and Pneumatic Apparatus.

The Sets of Apparatus for illustration in the various branches, have been selected with a view to combine the illustration of as many *principles* as possible, and from the various prices will doubtless assist the teacher in his selections. In their selections, great advantage will be noticed from the uniformity of our screws connected with the Apparatus in all the departments. They are all of one size and thread, corresponding with that adopted by the English Instrument Makers, and was procured from London at the commencement of our establishment in 1829. This screw has always been used, and all parts of a collection of Apparatus being thus adapted to each other, the greatest variety of *principles* can be illustrated with the smallest number of instruments.

Another distinguishing feature in our Apparatus is, that all the illustrations are adapted to certain Receivers, and but two or three are required in a Set, thus avoiding a fruitful source of expense.

As much of the Apparatus is required by institutions remote from the manufacturer, it becomes important that the teacher should be able to repair it himself; many changes in the forms of the Instruments have been made for this object, and illustrative manuals have been prepared for describing the various parts and methods of manipulation. The "Companion to the Air Pump" already issued, has been received with much favor, and I have now ready for the press, a similar "Companion to Electricity," which, from the variety of original Apparatus, will be found very useful.

In our business, much of the success depends upon a knowledge of the use to which the Instruments are applied, and in Chemistry, an experiment may not simply fail, but be dangerous,

from some defect or error in the construction of the Apparatus. Through the kindness of Prof. SILLIMAN, I have had the pleasure of assisting in the preparation of his experiments, and management of the Apparatus in the Laboratory, and Lecture Room, during his extensive course of Chemical Lectures, at the Lowell Institute, of this city, and I have thus been able to greatly improve and add to my list of Apparatus in this department. I have also derived much valuable information relating to Motion and Pneumatics, from the extensive Apparatus made by me under the direction of Prof. J. LOVERING, of Harvard University, for his course of Lectures, also at the Lowell Institute.

Through the attention of Mr. CLAXTON, (my former partner, residing in London,) I receive information respecting improvements there; as also additional facilities for manufacturing my own Instruments, as well as the benefit of his personal selection of Apparatus imported from thence.

I am happy to state that I have made arrangements for receiving from Paris a constant supply of beautiful brass mounted Achromatic Telescopes with Astronomical powers, of such prices as will be within the means of most Academies and High Schools. This has been long desired by my friends, and I am gratified in being able to offer them so beautiful an Instrument at a moderate price.

“Carpenter’s Phantasmagoria Lantern” and Sliders, imported by me, have continued to advance in estimation, and the increased demand for them is evidence of their superiority. The simplicity of the Lantern and accuracy of the Sliders, added to the high magnifying power, enlarging the figure of 2 inches to 6 or 8 feet! with a clear field of view, renders it the best instrument of the kind for instruction or public lectures.

The Galvanic Battery I have much improved for convenience and compactness, rendering it with the Apparatus all that can be desired,

The science of Electro-Magnetism is receiving considerable attention, and I have therefore selected sets of various extent for elementary illustration. The Apparatus in this department is made for me by DANIEL DAVIS, Jr., who confines his attention to this branch, and sustains a high reputation for the simplicity and efficiency of his Instruments.

Personally attending to the finishing, proving, and packing

of the Apparatus, customers may depend upon having their orders executed with promptness and care. And to show that their confidence would not be misplaced, I refer with pride and pleasure to the following

TESTIMONIALS.

YALE COLLEGE, Sept. 1, 1841.

MR. JOSEPH M. WIGHTMAN, of Boston, has constructed for me and my friends, many articles of Chemical and Philosophical Apparatus, during the last six years.

Recently, he has under my direction, executed an extensive order for the Lowell Institute, of Boston; and in *all* cases given me *entire* satisfaction. Among the skilful artists of Boston, Mr. WIGHTMAN holds a distinguished rank, and he is equally remarkable for his obliging disposition, and the zeal as well as efficiency with which he enters into the views of his employers.

B. SILLIMAN,

Prof. of Chemistry, Mineralogy, &c., in Yale College.

CAMBRIDGE, June 15, 1842.

MR. JOSEPH M. WIGHTMAN, of Boston, has made and repaired various kinds of Apparatus for me during the last six years. It gives me great pleasure to testify to his fidelity, ingenuity, and his despatch in executing the orders which I have constantly given to him during this period. At all times he has given me the greatest satisfaction and enjoyed my highest confidence; and I gladly recommend him as an ingenious, careful and courteous artist, to the patronage of scientific men.

JOSEPH LOVERING,

Prof. at Harvard University, of Mathematics and Natural Philosophy.

PENFIELD, GEO., Aug. 13, 1841.

I have for several years past used in my School, the Apparatus of MR. JOSEPH M. WIGHTMAN, Boston. The mechanical part is neatly and faithfully executed. It is well calculated to illustrate the principles of Chemical and Philosophical Science, in a pleasing and satisfactory manner. Several considerations render it worthy of the attention of teachers and patrons of Academies and Colleges. It is remarkable for its simplicity in construction and adaptedness to the present improved state of education.

THOMAS B. SLADE,

Principal Penfield Female Seminary, Georgia.

The following is extracted from the Report of the Judges on Philosophical Apparatus, at the First Mechanics' Fair, held in this city, Sept. 1837.

No. 568. CLAXTON & WIGHTMAN, Boston: Sectional Model of Steam Engine: Pneumatic Apparatus for Schools: Table Air Pump and Appa-

ratus : large Air Pump and Apparatus : Orreries : these articles are thoroughly made and well finished.

* * * * *

CLAXTON & WIGHTMAN deserve great credit for the improvements they have introduced in the manufacture of Philosophical Apparatus. Many of their articles have either been invented or greatly improved by them.

A SILVER MEDAL.

GEO. B. EMERSON, PROF. ANDREWS,	}	<i>Judges.</i>	{	S. P. MILES, AARON BREED, EBEN. BAILEY.
------------------------------------	---	----------------	---	---

Report of the Judges on Philosophical Apparatus, at the Second Mechanics' Fair, Sept. 1839.

No. 1142. J. M. WIGHTMAN, *Boston*: Air Pumps and other Pneumatic Apparatus. The maker of this Apparatus deserves very great credit for persevering to the present day in a long continued series of successful attempts to improve, simplify and render cheap and accessible to the public, as a means of instruction, almost every kind of Philosophical Apparatus. The improvements in the Air Pump, by overcoming the resistance by the downward motion of the break, instead of the circular motion of the winch, by using one larger, instead of two smaller Barrels ; by simpler valves and more durable packing, are of great value. He has also been constantly giving a better finish to his work, so as really to have elevated the standard of workmanship in this department.

A SILVER MEDAL.

GEO. B. EMERSON, JOS. HALE ABBOTT,	}	<i>Judges.</i>	{	S. P. MILES, PROF. J. W. WEBSTER.
---------------------------------------	---	----------------	---	--------------------------------------

Report of the Judges on Philosophical Apparatus, at the Third Mechanics' Fair, Sept. 1841.

No. 707. JOSEPH M. WIGHTMAN, *Boston*, whose Instruments have commanded the favorable notice of former committees, for the ingenuity of contrivance, excellence of arrangement and faithfulness of workmanship, put in six Air Pumps, and a considerable variety of other Apparatus.

No. 1, is an improved Leslie's Air Pump, well made and well finished. Mr. WIGHTMAN's improvements in this Instrument are—1. The application of a brass box immediately under the Pump plate, so constructed as to prevent mercury or other liquid from easily passing from the plate into the pump. 2. The addition of a brass box connected with the eduction valves, to receive any oil which may be thrown out of the pump, and of a form and construction, making it secure in this respect when the pump is used for condensing ; and—3. An arrangement of the safety box at the top

of the Barometer Gauge, such that if the mercury is drawn into it, it falls back of itself into the cistern and cannot enter the pump.

Nos. 2 and 3* are well finished Instruments, and appear to possess over Claxton's Lever Air Pump a decided advantage, derived from the application of a close cover and packing box, by means of which they are worked with greater ease even when the area of the cylinder is increased. Other improvements are made in their transferring and condensing power, and also in the application of the safety box and float-gauge.

The other Instruments exhibit improvements in form, and in the neatness of their construction. Mr. WIGHTMAN'S Bell for Vacuum, his application of the Ball and Socket Handles to the Hemispherical Cups, his arrangement of Windmills for a vacuum, his large and small Transferrers of Liquids, and his mode of closing the tops of Glass Apparatus by ground plates instead of caps and cement, we consider as other instances of the successful application of mechanical ingenuity to produce decided improvements in the structure and use of these Instruments.

A GOLD MEDAL.

JUDGES.

S. P. MILES, *Principal Young Ladies' School.*
 GEORGE B. EMERSON, *Principal Classical School.*
 PROF. J. LOVERING, *Harvard University.*
 THOMAS SHERWIN, *Principal English High School.*
 PROF. D. TREADWELL, *Harvard University.*
 SOLOMON ADAMS, *Principal Young Ladies' School.*
 U. A. BOYDEN, *Engineer.*
 S. BORDEN, *Massachusetts State Surveyor.*
 N. SNELLING, ESQ.

J. M. W. has also the pleasure of referring to

PROF. E. HITCHCOCK, *Amherst College, Mass.*
 PROF. E. S. SNELL, " " "
 PROF. O. P. HUBBARD, *Dartmouth College, Hanover, N. H.*
 REV. S. TAYLOR, *late Principal Model School, Sparta, Geo.*
 PROF. B. O. PIERCE, *Mercer University, Penfield, Geo.*
 H. K. OLIVER, ESQ., *Principal Classical School, Salem, Mass.*

* Wightman's Patent Lever Pumps.

LAWS OF MATTER.

Fig. 1.—No. 1.

INERTIA APPARATUS.

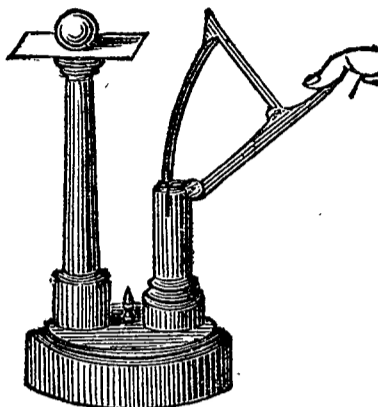

At Fig. 1 is shown a neat method of illustrating Inertia; a stiff card being projected by the spring without the Ball being removed from the Pillar.

MECHANICS.

SET OF MECHANICALS.

Fig. 2.—No. 23.

FRAME WITH PULLEYS AND WHEEL AND AXLE.

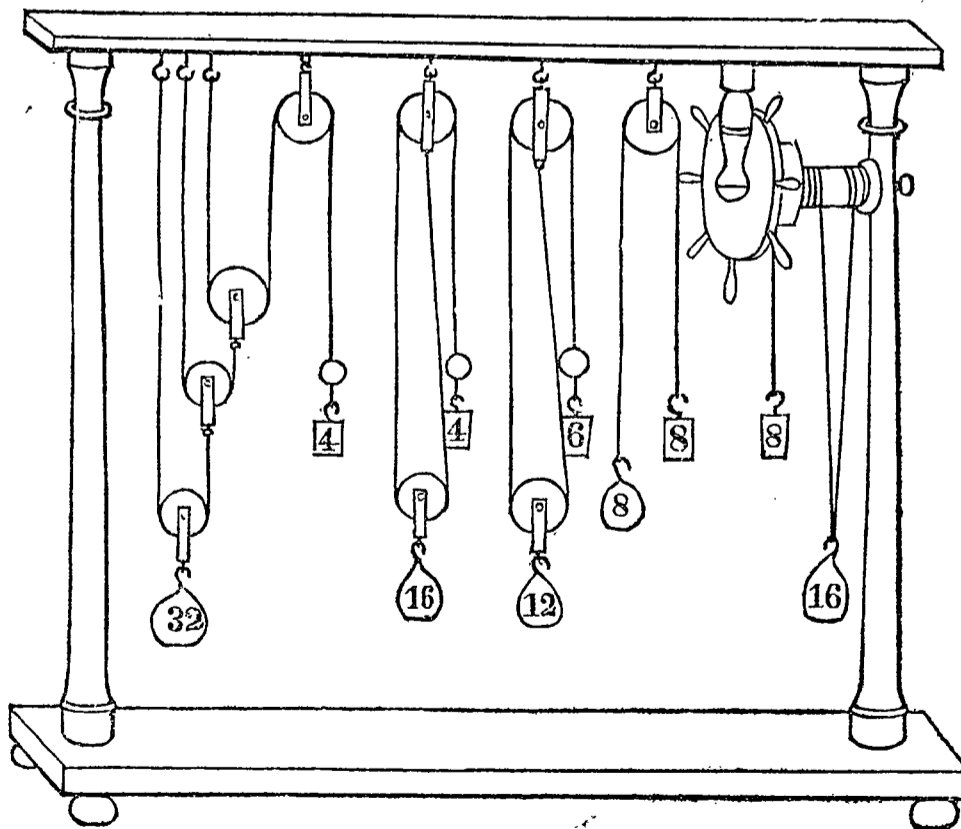

Fig. 3.

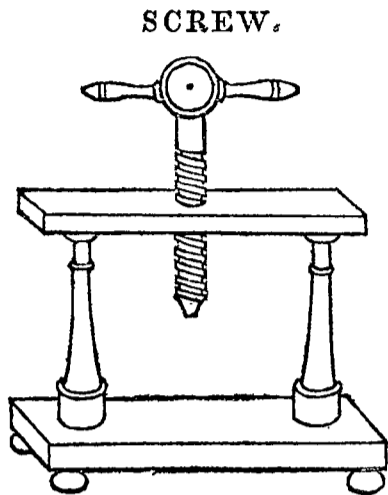

Fig. 4.

LEVERS.

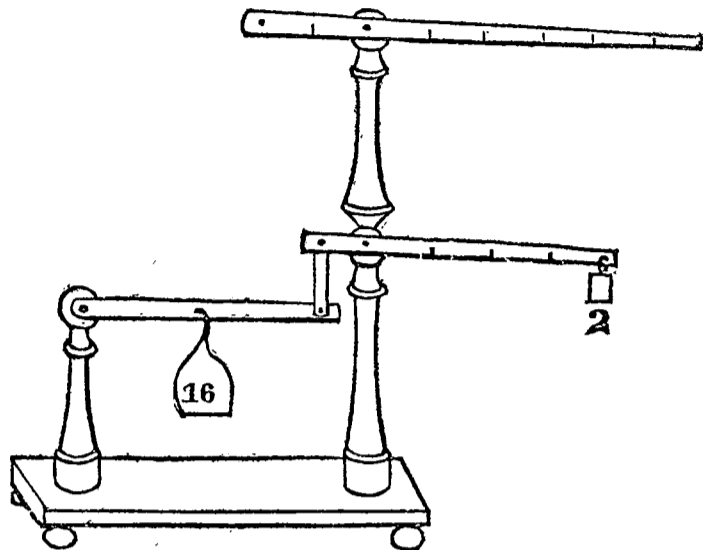

Fig. 5.

INCLINED PLANE AND CARRIAGE.

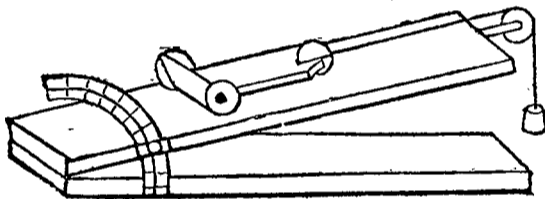
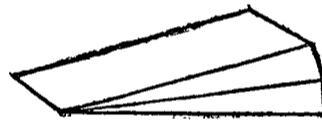

Fig. 6.

WEDGE.



Fig's. 2, 3, 4, 5, 6, comprise a complete set of Mechanicals which for ease of illustration and simplicity of arrangement, have been highly approved. Their being in detached parts, the teacher has no more before his class than he desires at the time. The Pulleys and Levers are of Brass, and all have Brass counterpoises or Powers. The Weights are of japanned iron to distinguish them from the Powers; all of them are graduated and marked with the ounces upon each. The movable Pulleys are balanced with brass balls placed upon the cord just above the Power, making a beautiful and convenient set. Price \$25.00.

Fig. 7.

FRAME WITH PULLEYS, WHEEL AND AXLE, AND CAPSTAN.

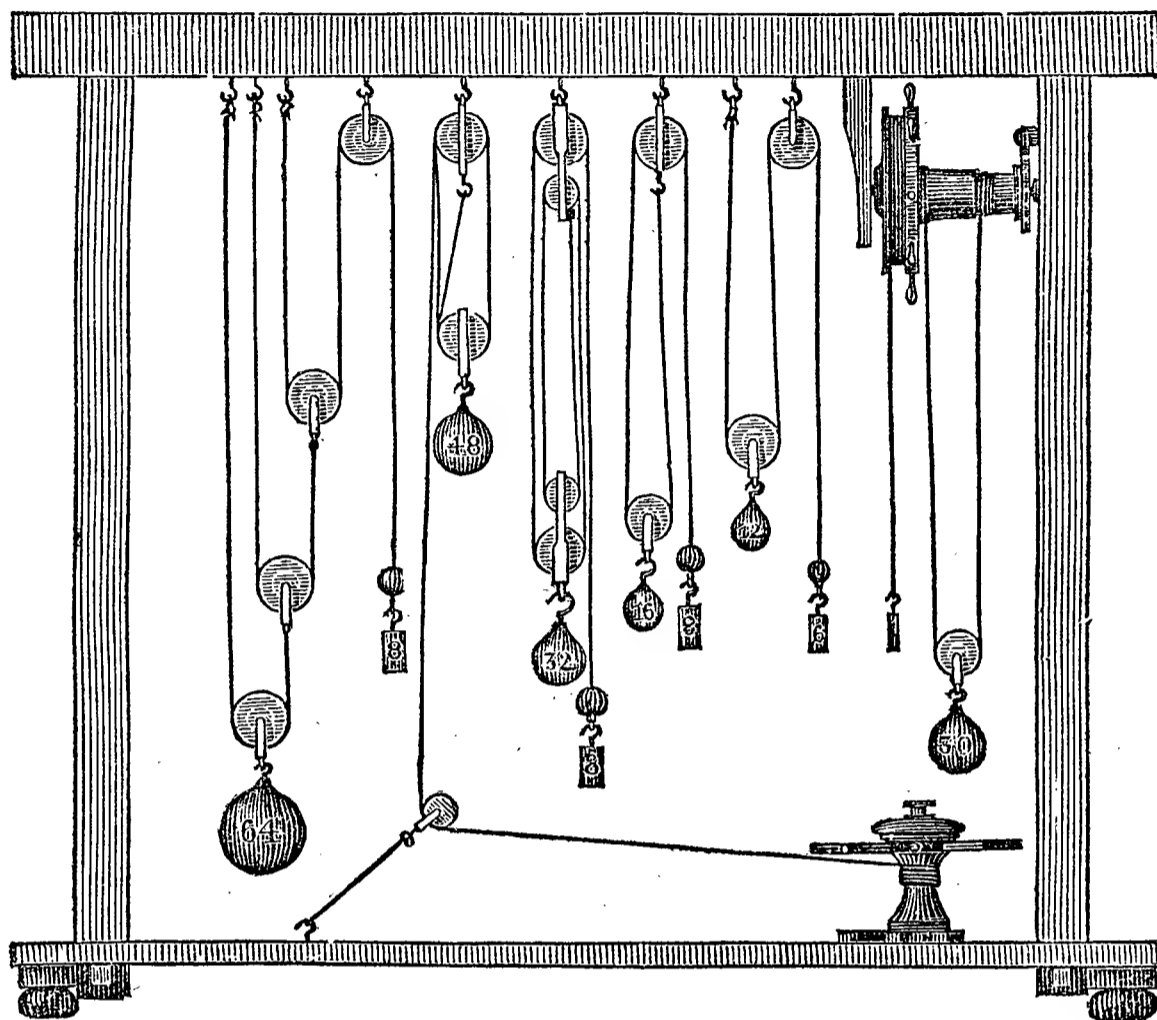

The Frames, as now made to *all* the various sizes of Mechanicals, have neat, turned pillars similar to Fig. 2. In the Medium Set, the Wheel and Axle, and Capstan, are arranged with the Pulleys, as shown at Fig. 7; but in the larger Sets the Wheel and Axle is mounted upon a separate stand. Upon the upper part of the Frames are two small Pulleys, over which a cord passes and is extended by suspending an 8 or 10 ounce weight to each end. If a 2 ounce weight is placed upon the centre of the stretched cord, it will bend it; to do which, this slight power overcomes the tension produced by both the other weights. A Power shown very forcibly in the

TOGGLE JOINT,

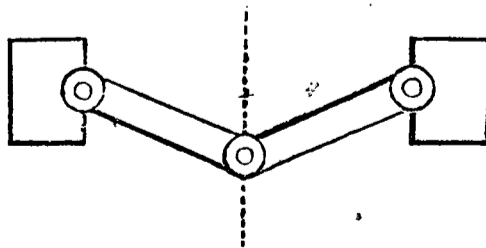

so extensively used, and beautifully adapted to printing and other Presses.

HYDROSTATICS AND HYDRAULICS.

Fig. 8.—No. 35.

HYDROSTATIC BELLOWS AND PARADOX.

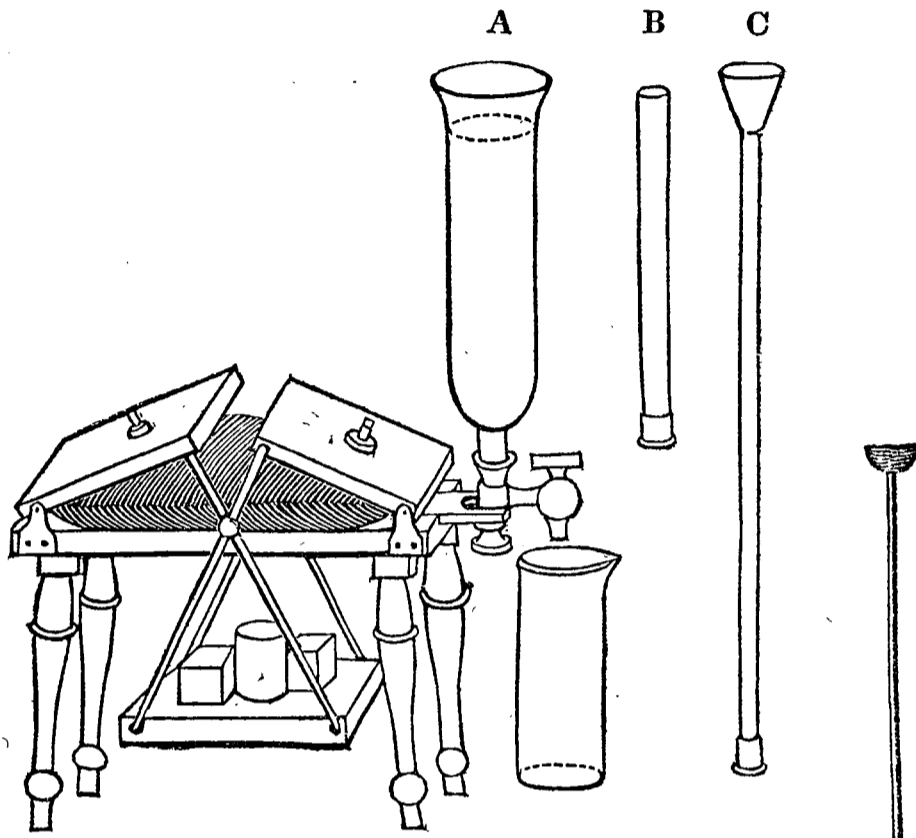

Price \$10.00.

Fig. 9.—No. 47.

WATER PUMPS.

Fig. 10.—No. 33.

HYDROSTATIC BELLOWS.

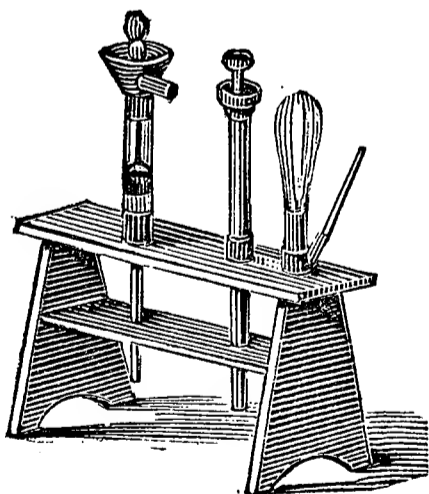

Price \$12.00.

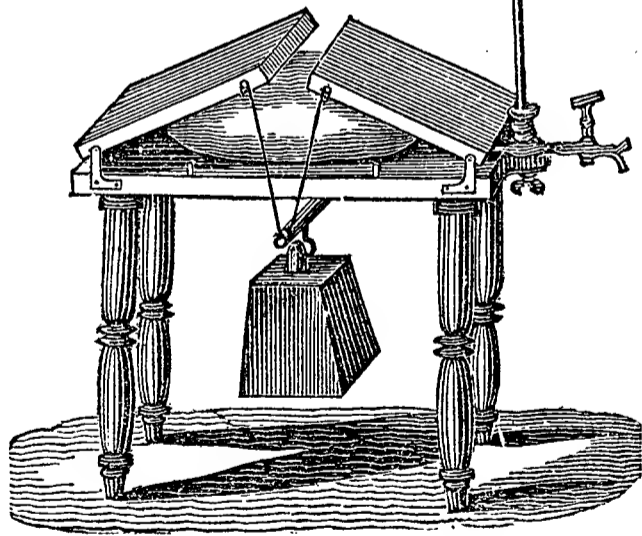

Price \$5.00.

Fig. 11.—No. 53.

HERO'S FOUNTAIN.

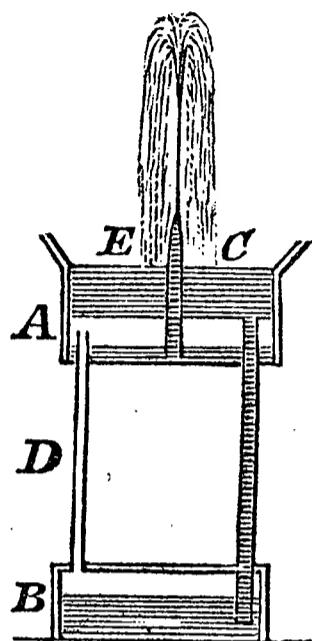

Fig. 12.—No. 50.

SYPHON CUP.

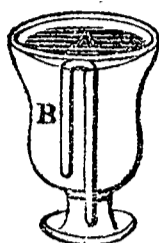

Fig. 13.

SPIRIT LEVEL.



Fig. 14.—No. 38.

UPWARD & DOWNWARD
PRESSURE.

Fig. 8 illustrates a new apparatus contrived to show in a striking manner, the interesting law that liquids press according to height and not to quantity. The vessel A is first filled with water, and weights put in the suspended scale until the pressure is counterbalanced; the water is then drawn off into the vessel and the tube B holding one tenth as much as A, is screwed to the same place; being the same *height* as A, the same *weight* will be raised when it is filled with water. C is a brass tube by which additional pressure may be given, and the apparatus used as a Hydrostatic Bellows.

Fig. 10 represents a form of the Hydrostatic Bellows, now well known and approved. Both of the foregoing possess the great advantage of being readily repaired when injured; as the India Rubber bag can be replaced at a trifling expense, or if inconvenient, a common bladder may be used in its place.

Fig. 14. A brass plate is held against the bottom of the glass vessel while it is plunged several inches under water. The *upward* pressure will then sustain the brass plate. Reverse the glass and put in the ball which will act as a valve, and will remain at the bottom of the glass by *downward* pressure, if carefully filled.

STEAM.

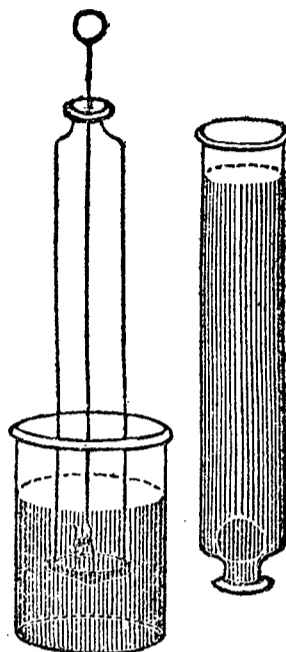
SECTION MODEL.

Fig. 15.—No. 65.

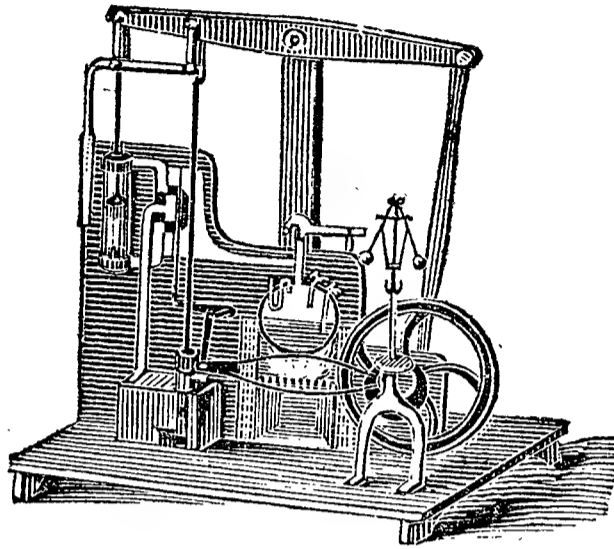
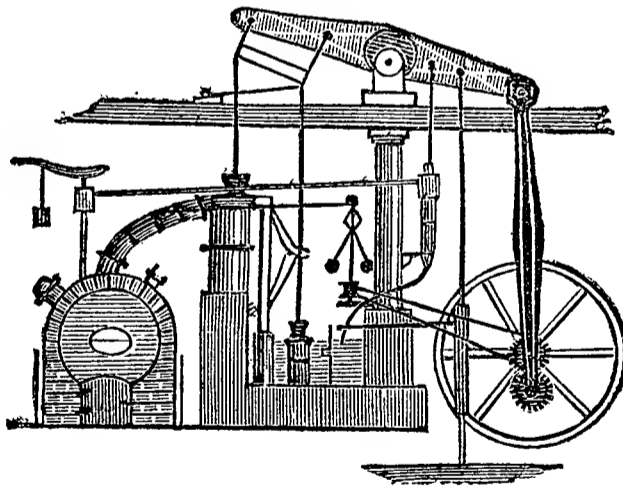

Fig. 15 represents a Section Model of the Steam Engine, as made by Watt. All the internal structure is shown, and the parts put in motion by turning the crank of the Fly wheel. It also illustrates the high and low pressure principles. This has been much preferred by teachers to a working model, not only on account of its low price, but perfect illustration. Prices \$12.00 to \$25.00.

WORKING MODEL.

Fig. 16.



At Fig. 16 is shown an Operating Model of Watts' low pressure Engine. This is beautifully finished and enclosed in a glass case. Price \$250.00.

PNEUMATICS.*Set No. 1.*

SCHOOL AIR PUMP WITH APPARATUS, IN CASE.

Fig. 17.—No. 86.

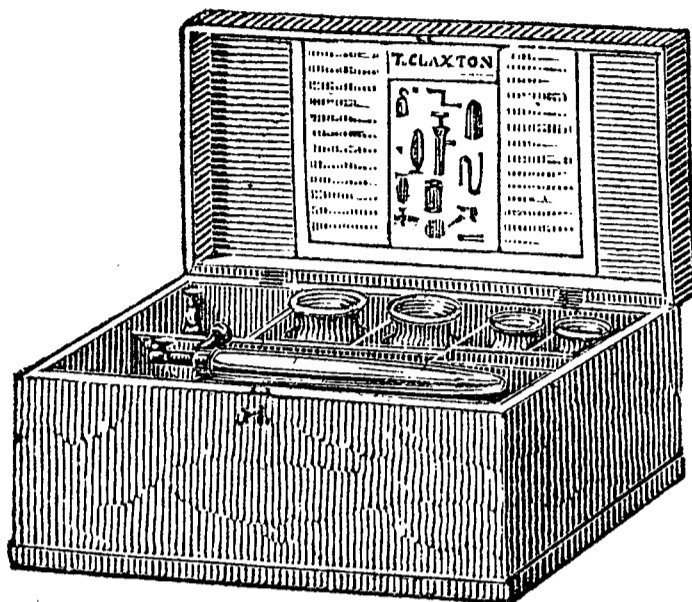

Fig. 18.

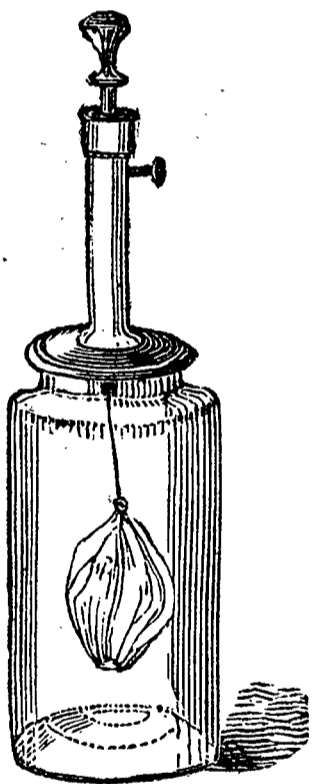

Fig. 19.

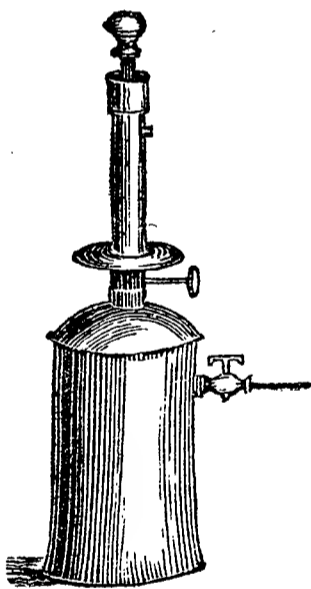
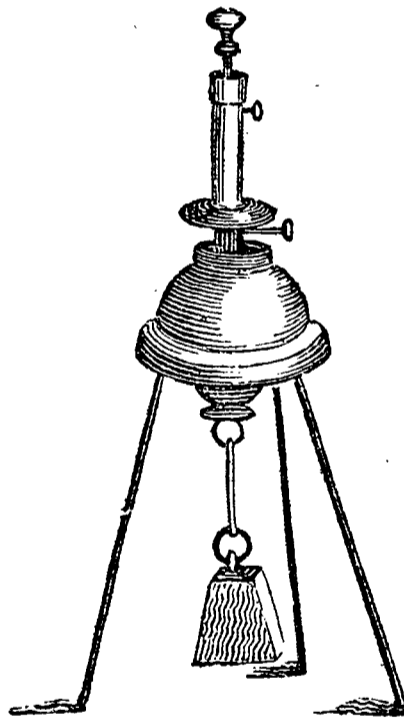

Fig. 20.



The case represented by Fig. 17, contains an Air Pump for exhausting and condensing, and the following apparatus,

Hemispherical Cup,
Apparatus for Weighing Air,
Two Glass Jar Receivers,
Bolt Head, and Jar,
Balloon and Jar,
Copper Air Fountain, Fig. 19,
Revolving Jet, [and Jet,
Glass Fountain for Vacuo, Cock

Block of Wood,
Resisting Fans,
Weight Lifter, Fig. 20,
Leather Sucker and Block,
Glass Suction Tube,
Glass Barrel Lifting Pump,
Glass Funnel,
Cup for Refraction.

With illustrated book of directions. Price \$35.00.

Set No. 2.

NEW SCHOOL AIR PUMP ON STAND, WITH APPARATUS.

Fig. 21.—No. 85.

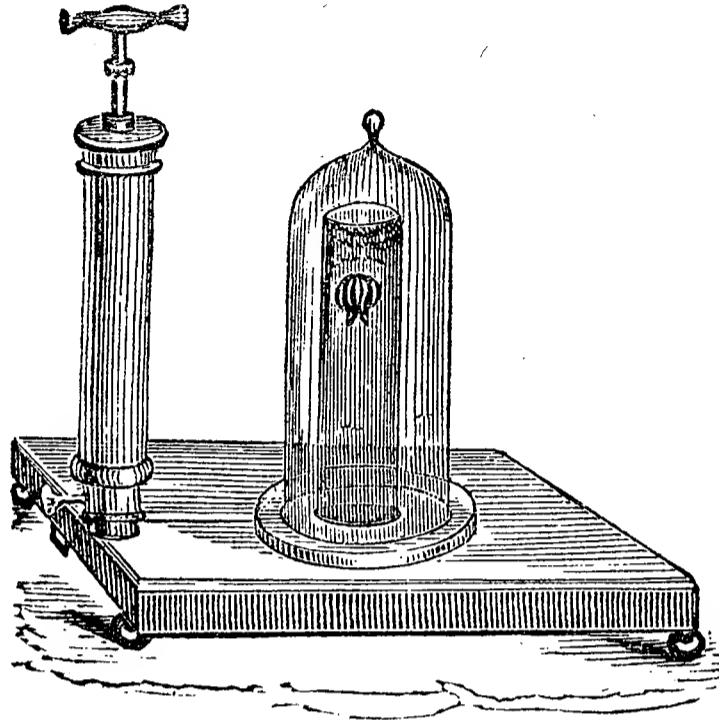

The Air Pump in this Set will exhaust or condense the air; the Barrel is $1\frac{1}{2}$ inches in diameter, and mounted on a neat mahogany base, with brass clamp to secure it to the table. A great number of this Set have been sold, and in all cases given entire satisfaction for neatness and efficiency. The apparatus consists of

Open Top Bell Receiver,
Tall Bell Receiver,
Brass Hemispheres and Cock,
Bladder and Hand Glasses,
Copper Air Fountain,
Revolving Jet,
Glass Syphon,
Glass Balloon,
Glass Bolt Head,
Glass Suction Tube,
Tall Glass Jar for Balloon,

Glass Jar for Bolt Head,
Glass Fountain for Vacuo,
Stop Cock and Straight Jet,
Improved Weight Lifter, raising from 50 to 100 lbs. by the pressure of the Air,
New Apparatus for Weight of Air,
Brass Plate and Wood Cylinder, for Porosity.
Resisting Fans and Handle.

Price of Set, \$40.00.

Set No. 3,

Includes all the above, and in addition,
Model of lifting Pump on Stand, | Liquid Transferrer,
Glass Pneumatic Paradox, | Flexible Connecting Tube.

Price of Set, \$50.00.

Set No. 4.

CLAXTON'S PATENT AIR PUMP, WITH APPARATUS.

Fig. 22.—No. 84.

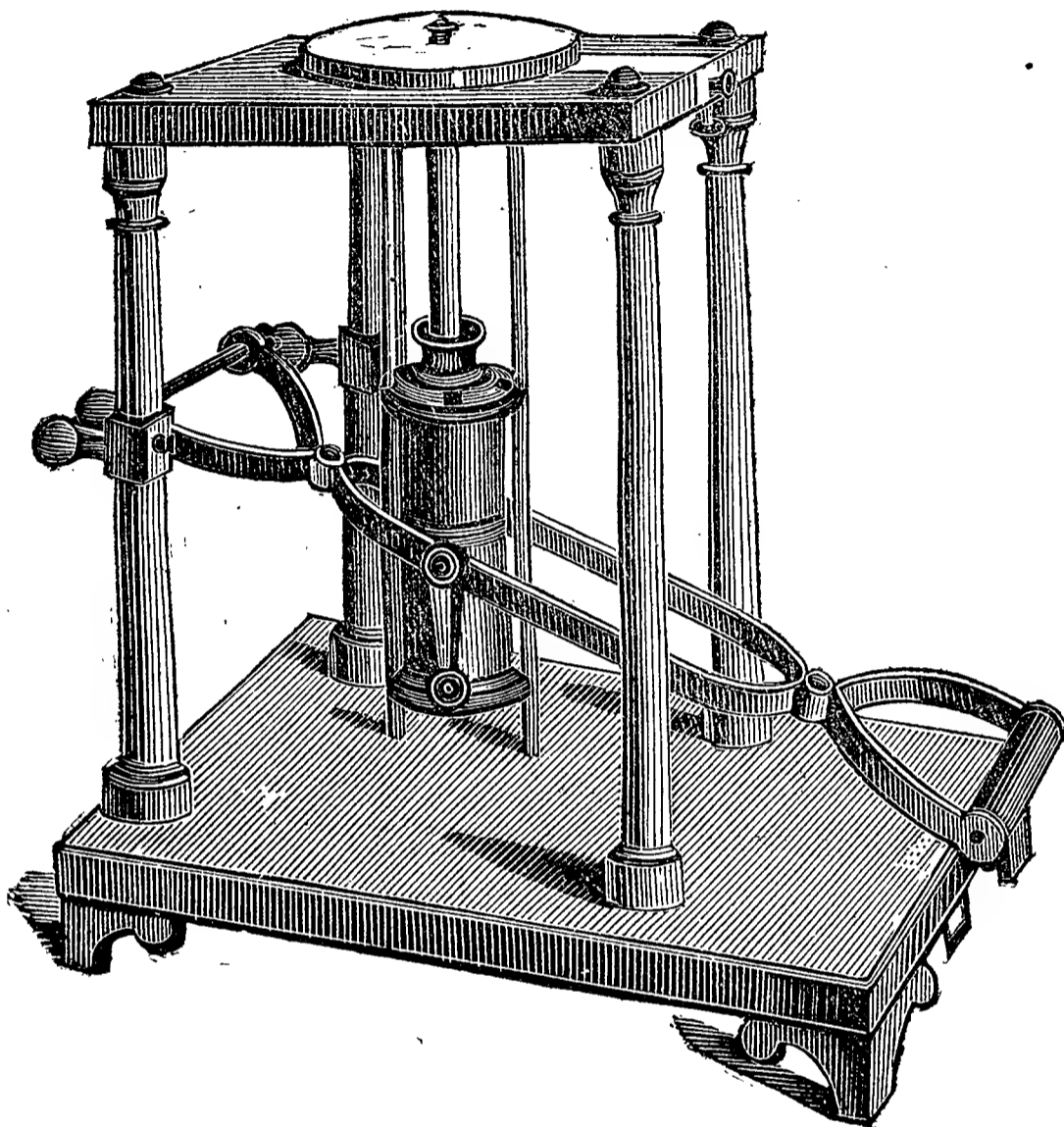

The Air Pump represented by Fig. 22, has now been too long and favorably known to require more than a brief summary of its peculiar advantages. The simplicity of its construction, and ease of operation, is combined with rapid and accurate exhaustion. The raised plate, besides adding beauty to the instrument, permits all the working parts being placed under it, and suffers the experiments to be seen distinctly from all points. This pump has recently been enlarged in all its parts, and the wood work rendered much neater; but from the increased demand for them, this has been done without enhancing the price. For Academies this has been extensively introduced. The set as usually selected and recommended, consists of

Lever Air Pump,	Tall Open Top Receiver,
Swelled Open Top Receiver,	Plain Bell Receiver,

Bolt Head and Brass Plate, New Weighing Apparatus, Brass Hemispheres, Guinea & Feather Experiment, Exhausting and Condensing Syringe, Glass Suction Tube, and Brass Plate for "Pump in Vacuo," Sliding Rod and Hook for Brass Plate, [Liquid, Glass Apparatus for transfer of Glass Vessel, Cock, and Jet, for Fountain in Vacuo, Plate and Wood for Porosity,	Glass Syphon, Glass Funnel, Hand Glass, Bladder Glass, Weight Lifter on Stand, for rais- ing 100 lbs. by the pressure of the air. Torricellian Experiment, Copper Condensed Air Foun- tain, Revolving Jet, Tall Jar for Balloon, Glass Balloon, Glass Jar for Bolt Head, with "Companion to Air Pump."
--	--

Price of Set No. 4, \$75.00.

Set No. 5.

The foregoing, together with,

Improved Bell for Vacuum, New Piston Apparatus for Ex- pansion, Water Hammer, Model of Lifting Pump on Stand,	Breaking Cubes and Guard, Mercury Shower, Transferring Apparatus for Smoke, &c. &c. Flexible Connecting Tube for Weight Lifter,
--	--

Price of Set No. 5, \$100.00.

Set No. 6.

WIGHTMAN'S PATENT PORTABLE AIR PUMP, WITH APPARATUS.

This Pump combines all the advantages of construction of the Table Lever Pump, Fig. 25, in a portable form. The Levers are of Brass, and every part is highly finished. The Gauge is enclosed in a glass case, with a stop cock, and should always *remain closed*, except when required for accurate experiments; as the air let in suddenly by withdrawing the hand, or breaking a bladder, would probably injure, if not break the tube.

If by accident any liquid should flow into the pump, it passes unobstructed to the bottom of the barrel, and is then easily drawn off by a screw in front.

Fig. 23.—No. 83.

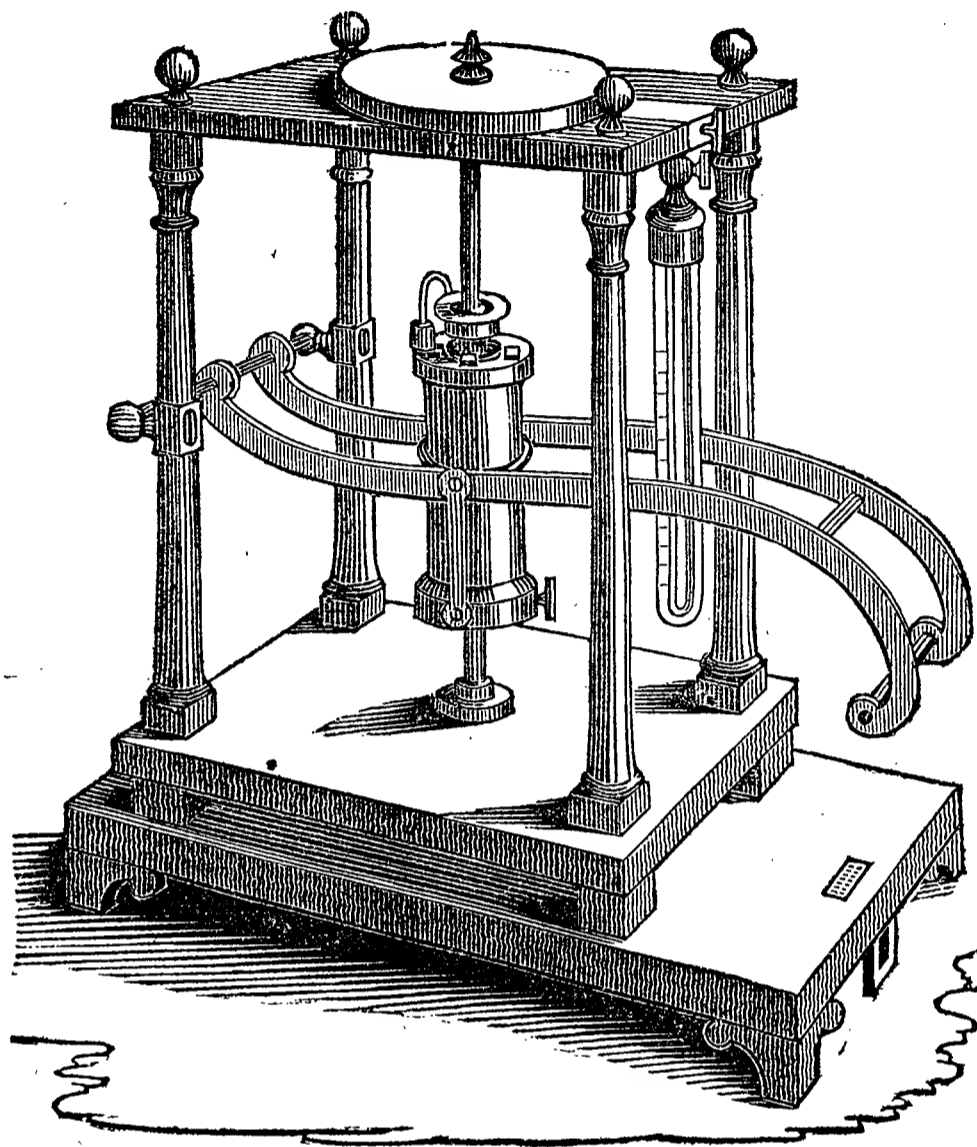

A set of apparatus includes,
 The Air Pump,
 Swelled Receiver,
 Tall Receiver,
 Plain Bell Receiver,
 Bolt Head and Plate,
 Receiver and Pans for Freezing of Water,
 Brass Hemispheres,
 Mercury Shower,
 Tube, Guinea and Feather Experiment,
 Hand Glass,
 Bladder Glass,
 Fountain in Vacuo,
 Bell for Vacuum,

Flexible Tube for Weight Lifter,
 Weighing Apparatus,
 Weight Lifter,
 Tall Jar and Balloon,
 Exhausting and Condensing Syringe,
 Glass Suction Tube,
 Brass Plate for "Pump in Vacuo,"
 Sliding Rod and Hook for Brass Plate,
 Copper Condensed Air Chamber,
 Revolving Jet.

Price of Set No. 6, \$100.00.

Set No. 7.

CLAXTON'S TABLE LEVER AIR PUMP AND APPARATUS.

Fig. 24.—No. 82.

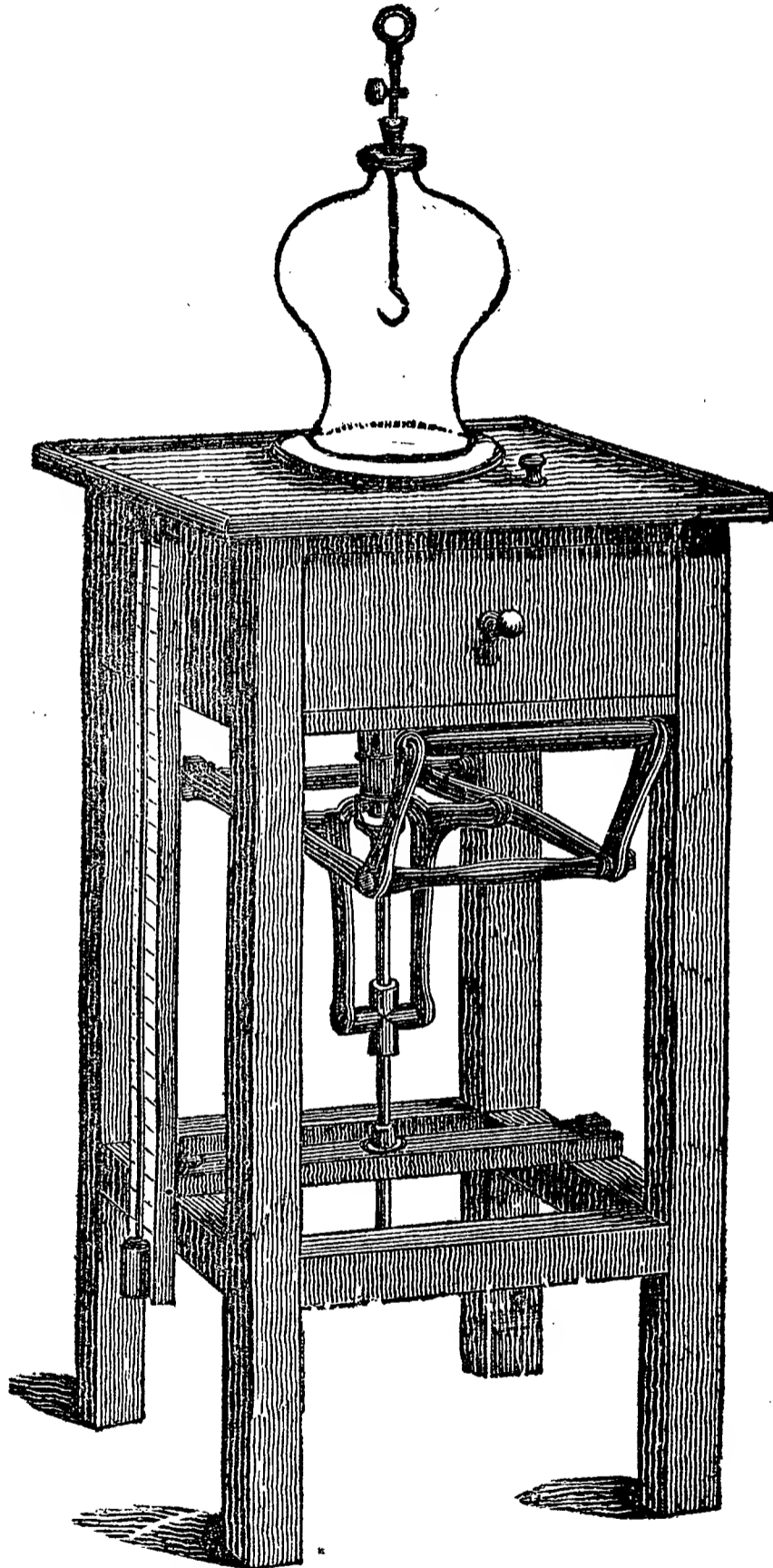

Price of Pump, \$50.00.

Price of Apparatus, from \$50.00 to \$75.00.

Set No. 8.

WIGHTMAN'S PATENT LEVER PUMP ON HIGH STAND.

Fig. 25.—No. 80.

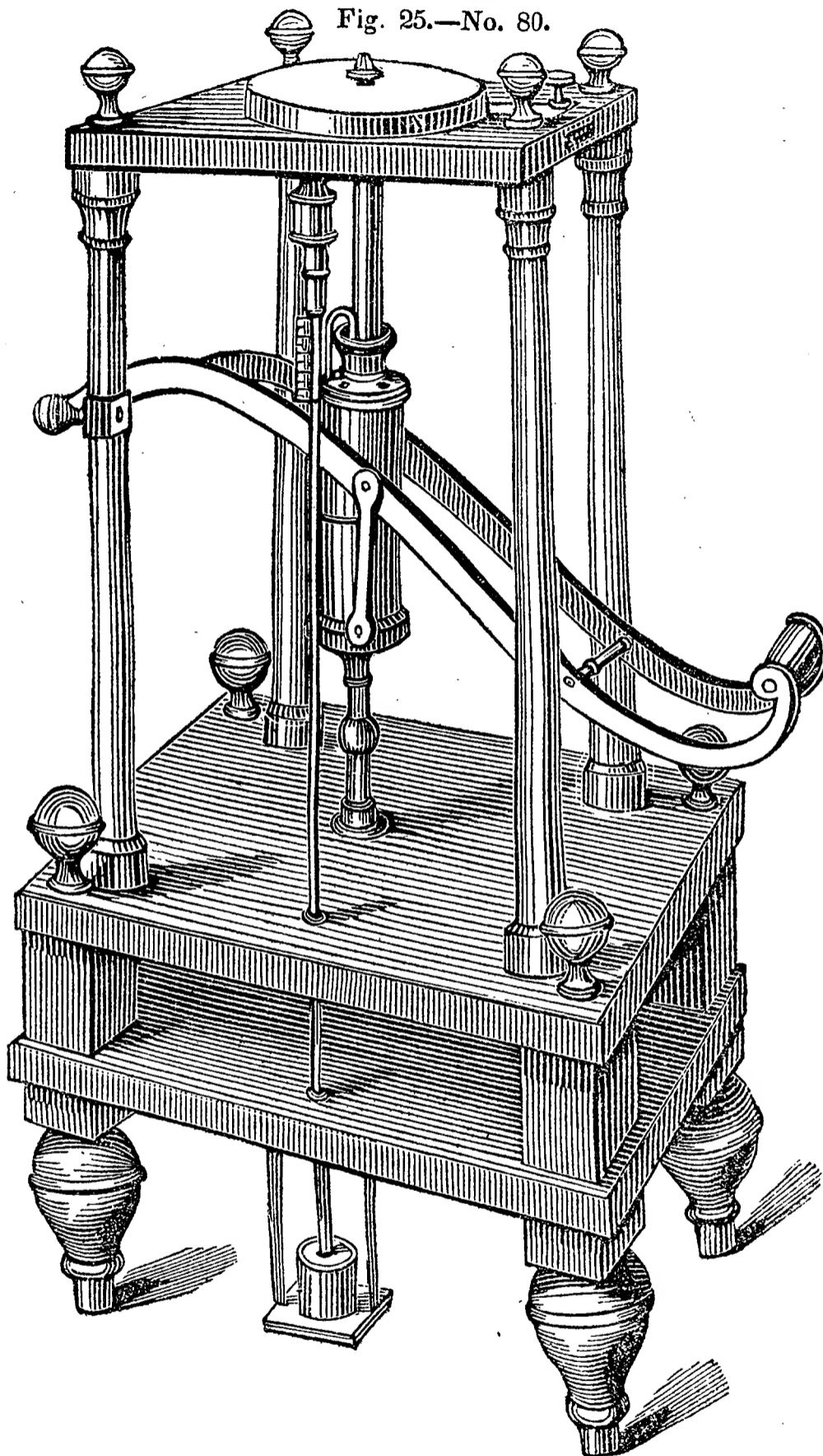

This Pump not only exhausts the Air, but from its peculiar construction, combines both the power of condensing and transferring Air or Gas, while at the same time, the accuracy of exhaustion and ease of operation is increased. This is produced

by the application of a tight cover and packing box to the top of the barrel; the power, therefore, required to operate it is constantly decreasing, until the receiver is exhausted, when there is no other resistance than the simple friction of the piston in the barrel. The valve on the lower end of the piston is dispensed with, and the bottom of the barrel is made *concave*, so that any liquid or mercury passing into the pump can be immediately and effectually removed by a screw at the bottom of the barrel.

The Levers are of brass, and all parts are of the best workmanship. The scale of the Gauge floats upon the surface of the mercury, thus insuring accurate measurement; and a safety box upon the top of the tube effectually prevents mercury from being forced into the pump.

One of these pumps has been used for two years past in the Chemical Lectures before the "Lowell Institute," and another more recently in the Chemical department of Yale College, for the operation of which, in connection with other apparatus, I have the pleasure of referring to the testimonial of Prof. B. Silliman, and the report of the Judges at the Mechanics' Fair.

Price of Pump, \$75.00.

Price of Apparatus, \$75.00.

Set No. 10.

LARGE LEVER AIR PUMP ON LESLIE'S CONSTRUCTION.

The powerful instrument shown at Fig 26, is of the general construction devised by Prof. Leslie, for his celebrated experiment for the production of Ice from water by its own evaporation. The size, form and construction of our pump is from a beautiful instrument made in London, under the direction of Prof. Treadwell, for Harvard University. Several improvements have however been added to prevent injury from accidents. The Cylinder is 4 inches interior diameter, and 12 inches high; Pump plate 13 inches in diameter; Lever about 4 feet long. The frame is of solid mahogany firmly made and polished. It has a Barometer Gauge of 33 inches with Floating Scale, and a Syphon Gauge in Glass case, with a Stop Cock, to close at pleasure, and prevent accident from letting in the air too suddenly. The oil box, besides preventing the waste oil from being thrown about the frame, has also a screw to which may

be attached a flexible tube for Transferring, Condensing, &c. All parts of these pumps are made in the most thorough manner, and for colleges this instrument may be safely guaranteed *equal* to any imported, and the price at least one third less. The Apparatus designed for using with this Pump is of the largest size, mentioned in the list of prices; a full set of which was made for Prof. Lovering's Lectures at the Lowell Institute, and is well calculated for a very large audience. Price of Pump, \$150.00.

Fig. 26.—No. 79.

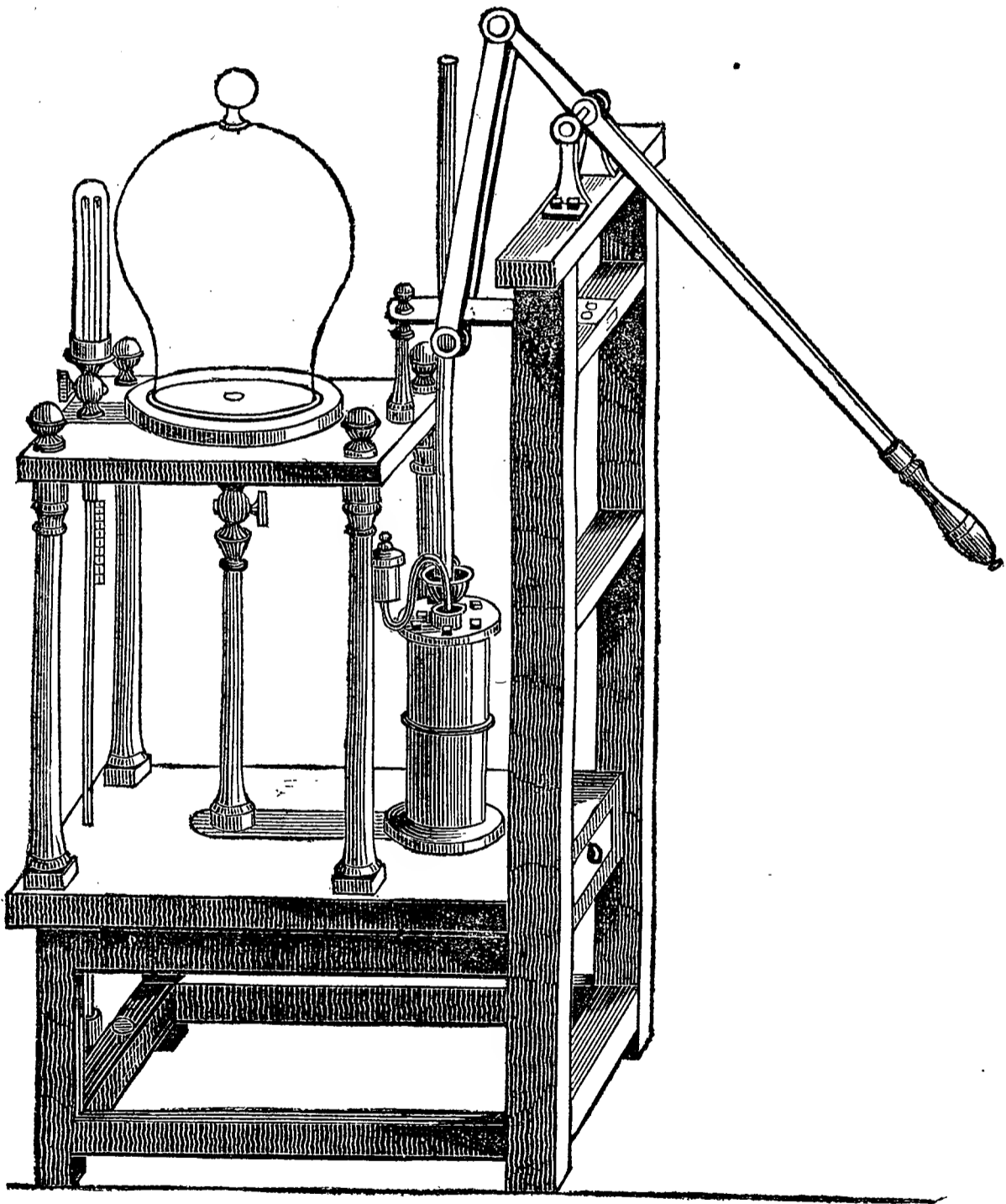

PNEUMATIC APPARATUS.

SEE "COMPANION TO AIR PUMP."

Fig 27—No. 91.

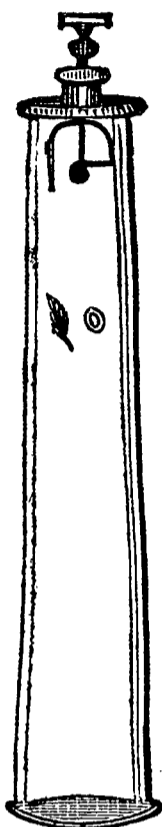

Fig. 28.
No. 99.

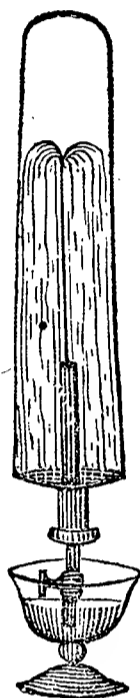

Fig. 29.
No. 121.

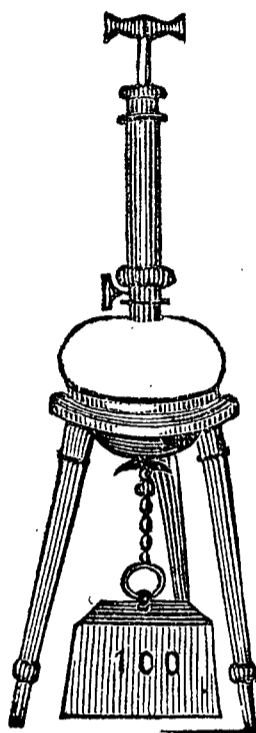

Fig. 30.
No. 103.

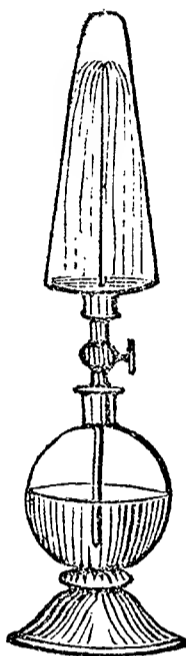

Fig. 31.



Fig. 32.—No. 144.

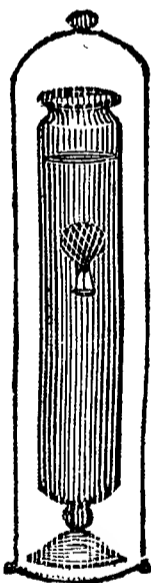

Fig. 33.
No. 134.



Fig. 34.
No. 94.

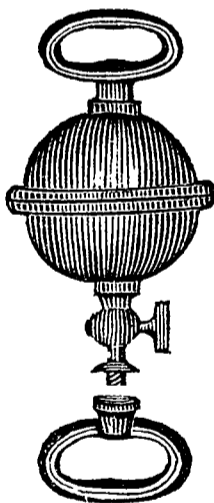

Fig. 35.—No. 124.

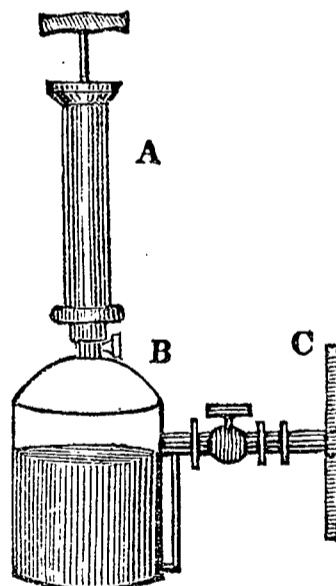

Fig. 36.
No. 131.



Fig. 37.—No. 150.

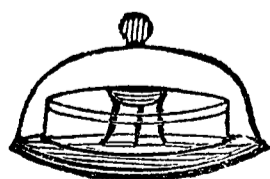

Fig. 38.—No. 138.

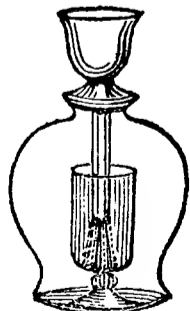

Fig. 39.—No. 118.

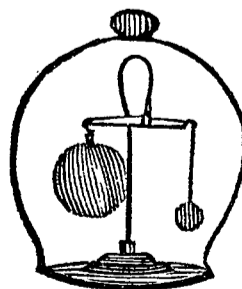

Fig. 40.—No. 116.



ELECTRICITY.

IMPROVED PLATE MACHINE.

Fig. 41.—No. 158.

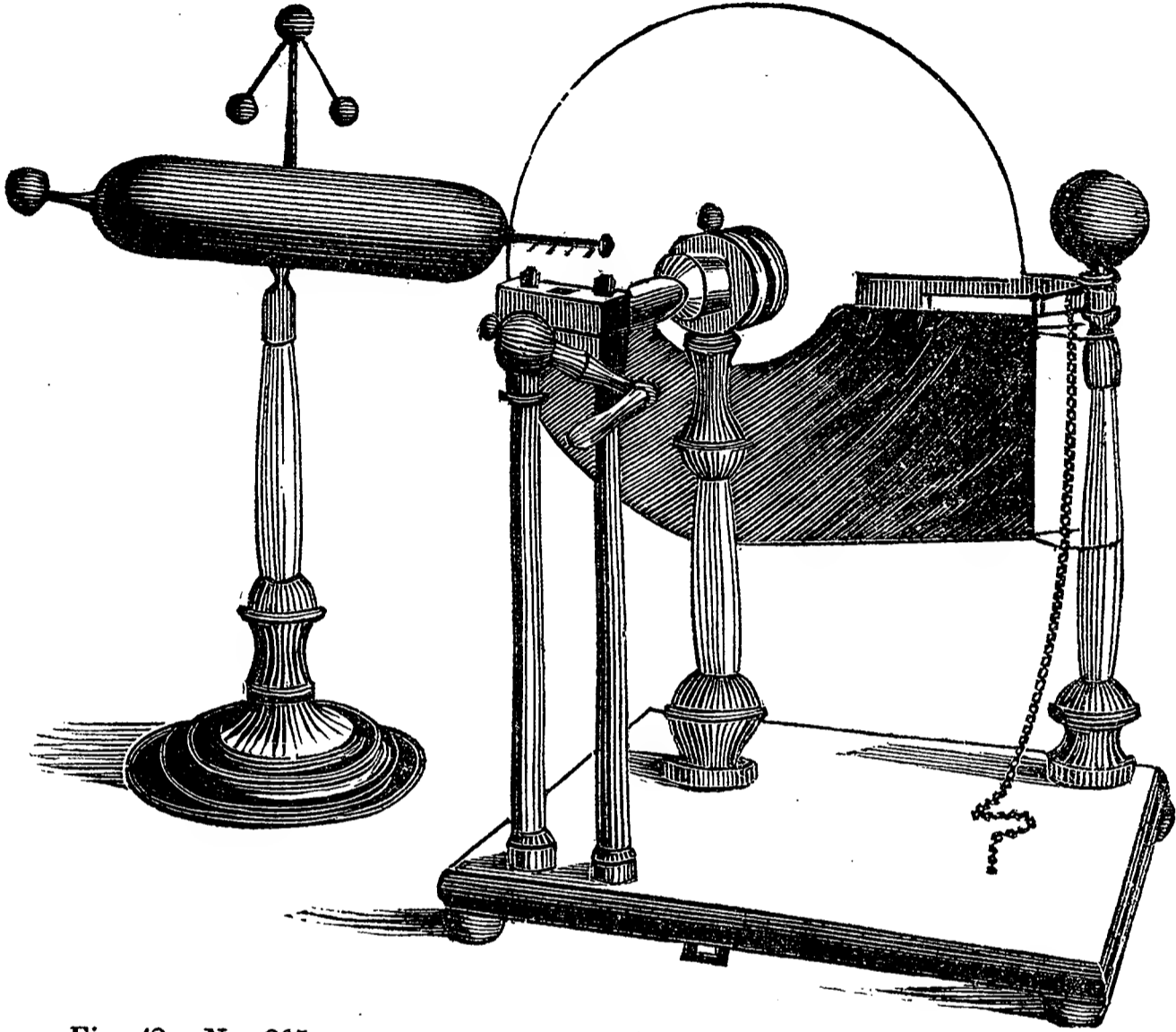

Fig. 42.—No. 205.

Fig. 43.—No. 227.

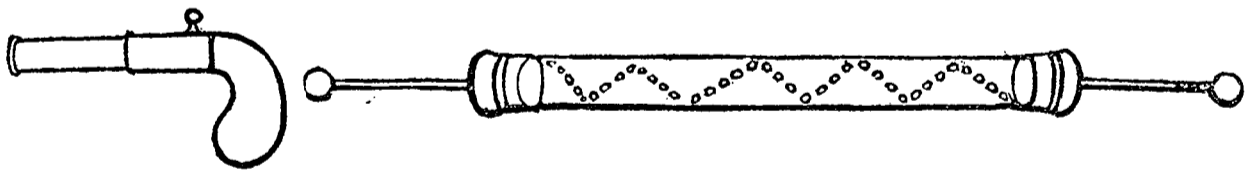
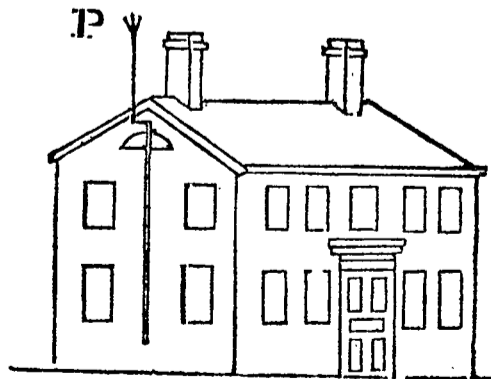
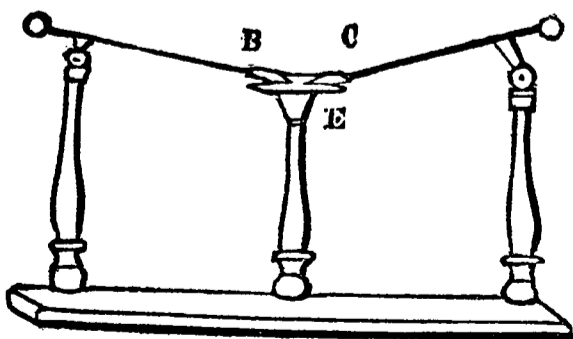

Fig. 44.—No. 170.

Fig. 45.—No. 202.



In the Machine shown at Fig. 41, the Plate is perfectly insulated by means of a glass shaft, which however does not, from the peculiar construction of the frame, sustain any weight of the plate. The Rubbers also being much longer, the rubbing surface is greater, rendering it more powerful of its size than in any other form. In the humid atmospheres of the South and West, it has been much approved, not only on account of its perfect operation, but from the strength and neatness of its mahogany mounting, which is not so liable to become injured or tarnished as when mounted with brass in the usual form. The cost of mounting in wood is somewhat greater than in brass, but it has been very rare that on comparison the former has not been selected. The prime conductor is of brass, highly finished, as are also the Rubbers, Springs, and Negative Conductor. Fig. 41, represents the form of the Improved Machines, for the table, when the plate is from 18 to 24 inches in diameter; when larger, the Machines are mounted upon bases to rest upon the floor.

Set No. 1.

Electrical Machine with 24-inch plate, with Brass Conductor.

Fig. 41.

Pith Ball Electrometer,	Jointed Discharger,
Battery of 9 Jars,	Universal “
Sportsman, Jar, and Birds,	Thunder House and Pistol,
Brass Image, Plates and figures,	Electric Tellurian,
Insulated Stool,	“ Swan and Glass Dish,
Miser’s plate,	“ Powder Bomb,
Chime of Bells,	Electric See Saw and Figures,
Aurora Tube, Balls and Cock,	“ Inclined Plane,
Jar with movable coatings,	Gas Generator,
Egg Stand,	Tissue Figure,
Spiral Tubes on stand, with	Fire House,
Revolving Balls,	Quart and pint Leyden Jars,
Polished Copal,	Sealing Wax,
Box Amalgam,	Brass Chains.

Price of Set No. 1, \$150.00

Set No. 2.

Electrical Machine, 20-inch plate, as Fig. 41.

Battery of 4, 3-quart Jars,	Jointed Discharger,
Quart Jar with Bent Rod,	Electrical See Saw,
Cylinder for Dancing Balls,	“ Sportsman,
Brass Image Plates,	“ Tellurian,
Chime of Bells,	Insulated Stool,
Tissue Figure,	Thunder House with Pistol,
Jar with movable Coatings,	Brass Ball and Point,
Powder Bomb,	Luminous Tube,
Tin Foil,	Brass Chain,
Box of Amalgam,	“ Clamp.

Price of Set No. 2, \$100.00.

Set No. 3.

Electrical Machine, 18-inch plate, as Fig. 41.

Battery of 4 Jars, one with Bent Rod,	Thunder House and Pistol,
Jointed Discharger,	Pith Ball Electrometer,
Brass Image Plates,	Powder Bomb,
Chime of Bells,	Insulated Stool,
Tissue Figure,	Miser's Plate,
Electric Tellurian,	Ball and Point,
Cylinder for Dancing Balls,	Box of Amalgam,
Brass Chains and Tin Foil,	Brass Clamp.

Price of Set No. 3, \$75.00.

Set No. 4.

Includes all of the articles in Set No. 3, and in addition,

Electrical Sportsman,	Aurora Tube, Balls and Cock,
“ Cannon,	Swan and Glass Dish,
“ Spider,	Egg Stand,
“ Star,	See Saw and Figures,
“ Inclined Plane,	Ether Cup,
Sealing Wax,	Polished Copal,
Box Pith Balls,	Glass Tube.

Price of Set No. 4, \$100.00.

Set No. 5.

Electrical Machine, 16-inch plate, Brass Mounted on Glass Pillars.

Fig. 46.

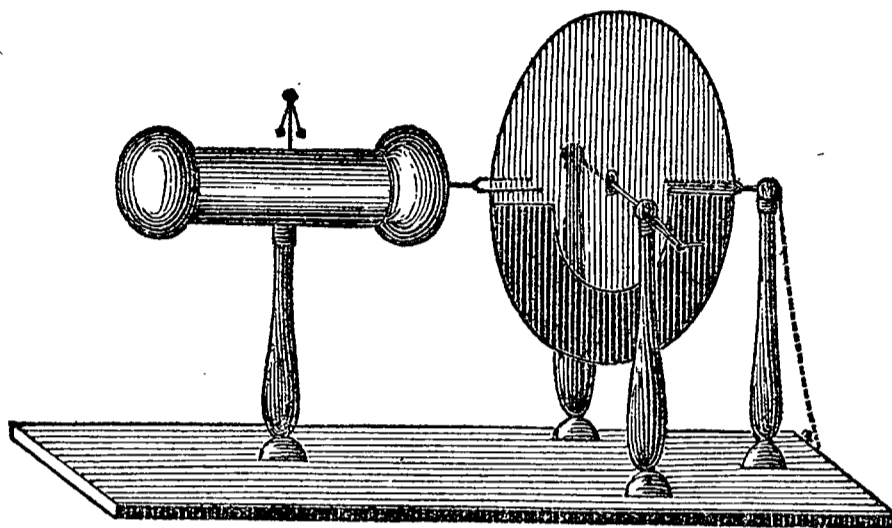

Battery of 4 Jars,
Insulated Stool,
Image Plates,
Plain Discharger,
Pith Ball Electrometer,
Long Haired Man,
Ball and Point,
Miser's Plate,
Chime of Bells,

Electric Flier,
" Spider,
" Star,
Prepared Ribands,
Sealing Wax,
Brass Chains,
Cylinder for Dancing Balls,
Box of Amalgam,
" Pith Balls.

Price of Set No. 5, \$50.00.

CYLINDER ELECTRICAL MACHINES.

These are beautifully and effectively mounted on mahogany stands, with brass and japanned Prime Conductor, and their operation is guaranteed equal to any manufactured. They are all thoroughly insulated for collecting either Positive or Negative electricity.

Set No. 1.

Electrical Machine, 10-inch Cylinder, with Set of Apparatus, as with plate Electrical, Set No. 2. Price, \$80.00.

Set No. 2.

Electrical Machine, 8-inch Cylinder, with Set of Apparatus, as with Plate Set No. 3. Price, \$60.00.

Set No. 3.

Electrical Machine, 8-inch Cylinder, with Set of Apparatus,
as with plate Set No. 5. Price, \$50.00.

Set No. 4.

Electrical Machine, 6-inch Cylinder.

Pith Ball Electrometer,
Leyden Jar,
Chime of Bells,
Plain Discharger,
Miser's Plate,
Gable End,
Image Plates,
Sportsman,

Sealing Wax,
Brass Clamp,
Electric Whirl,
" Swan,
Long Haired Man,
Brass Bucket,
Glass Tube,
Brass Chains.

Price of Set No. 4, \$30.00.

CHEMISTRY.**PYROMETER AND SPIRIT LAMP.**

Fig. 47.—No. 288.

**EOLIPILE.**

Fig. 48.—No. 68.



School Chemical Set, No. 1.

Copper Pneumatic Cistern, with Shelf, Improved Iron Retort, Conducting Lead Tube, Reflectors and Ball, Sliding Stand, Leslie's Cube, Air Thermometer, Three Test Glasses, Six Test Tubes, Long Neck Matrass, Dropping Tube,	Glass Graduated Measure, Improved Lamp Stand, Glass Cap Spirit Lamp, Pyrometer and Rod, Fig. 47, Brass Eolipile, Fig. 48, Wire Gauze, Compound Bar, Three Retorts, Two Bell Receivers, Tubulated " " Stirring Rods.
--	---

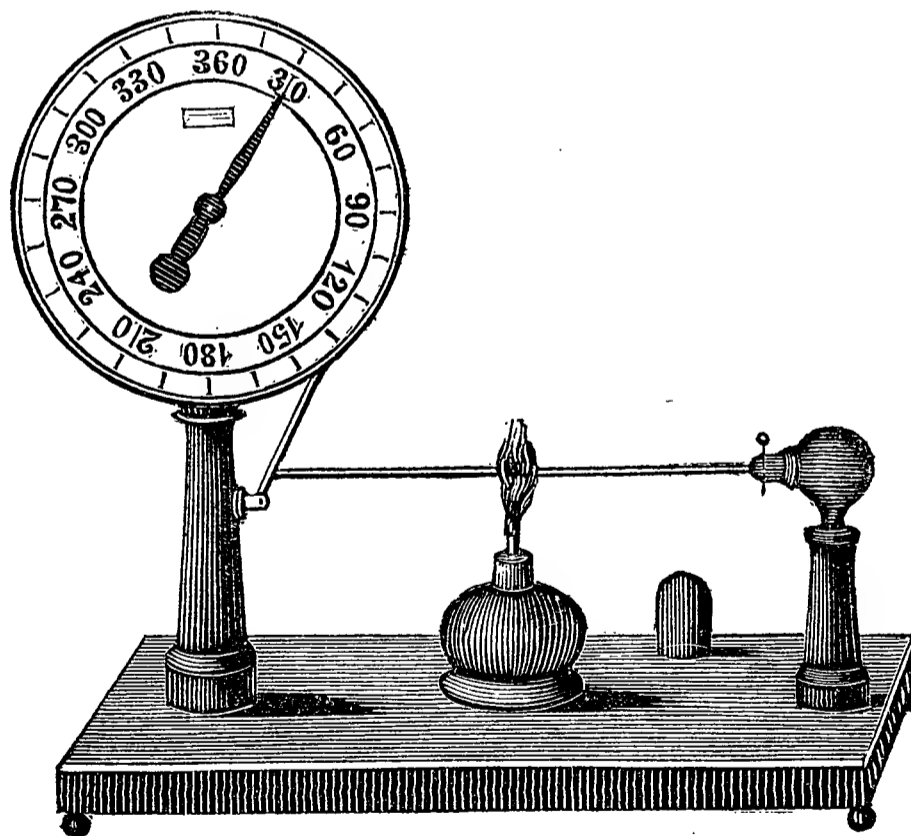
Price, \$25.00.

Set No. 2.

PNEUMATIC CISTERN AND COMPOUND BLOW PIPE.

Fig. 49.—No. 261.

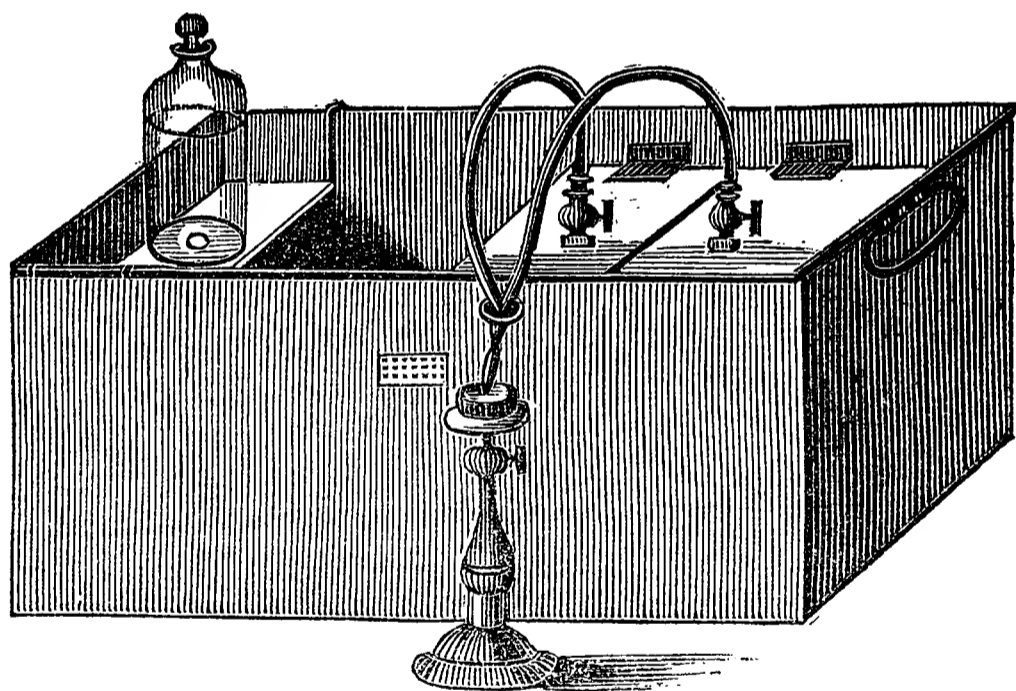

Set No. 2, includes all of the articles in Set No. 1, and in addition,

Pneumatic Cistern and Com- pound Blow Pipe, Fig. 49, Chemical Thermometer, A pair of Pulse Glasses in Box, Transferring Receiver,	Conductometer and Rod, India Rubber Gas Bag, Stop Cock and Jet, Bubble Pipe.
---	---

Price of Set No. 2, \$50.00.

Set. No. 3.

GAS GENERATOR.

Fig. 50.—No. 308.

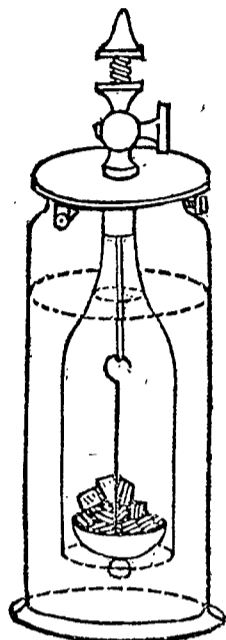

CHEMICAL THERMOMETER.

Fig. 52.

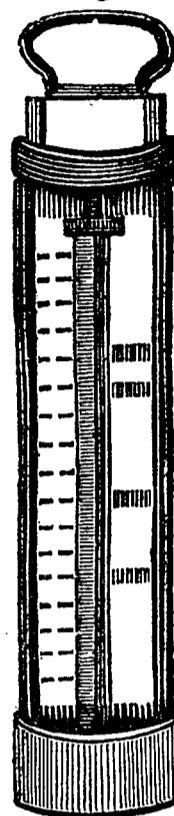

WOLLASTON'S CRYOPHERUS.

Fig. 51.—No. 330.

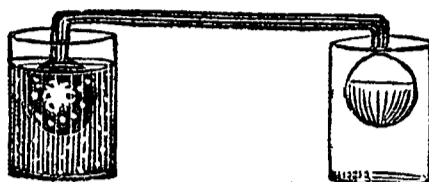

<p>In addition to the two preceding Sets, Set No. 3 contains,</p> <p>Two Quart Tubulated Bell Glass,</p> <p>Two Quart Plain Bell Glass,</p> <p>Brass Blow Pipe,</p> <p>Two Digesting Flasks, [50,</p> <p>Hydrogen Gas Generator, Fig.</p> <p>Portable Furnace,</p> <p>Tongs and Crucibles,</p> <p>Porcelain Pestle and Mortar,</p>	<p>Two Porcelain Evaporating Dishes,</p> <p>Fire Syringe,</p> <p>Wollaston's Cryopherus,</p> <p>“ Steam Apparatus,</p> <p>Box of Metals for Precipitation,</p> <p>Three Glass Funnel,</p> <p>“ “ Retorts,</p> <p>Set of Chemical Tests.</p>
--	---

Price of Set No. 3, \$75.00.

IMPROVED RACK COMPOUND BLOW PIPE.

Fig. 53.—No. 259.

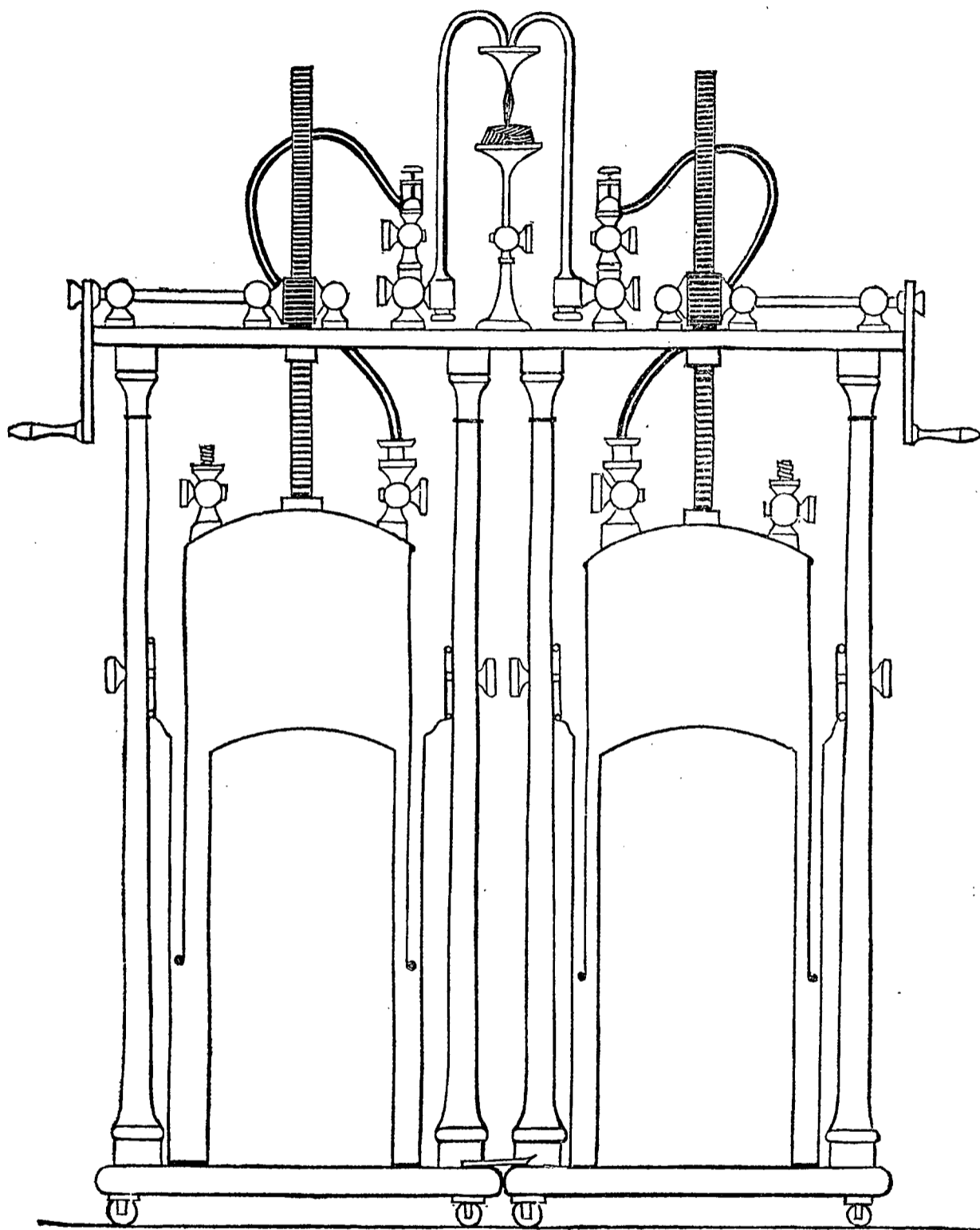

The above is a beautiful Oxy-Hydrogen Blow Pipe, on Hare's construction, made by me under the direction of Prof. B. SILLIMAN, for the Lowell Institute. The vessels are of copper, and the pressure is communicated by rack work, thus avoiding the trouble of heavy weights. The fixtures are of brass, and have every motion which may be required, and the whole operation

is exceedingly convenient. The Gas holders are on *separate* frames upon strong castors, and may thus be separated when but one Gas is required. Price complete, \$150.00.

OPTICS.

ACHROMATIC ASTRONOMICAL TELESCOPE.

Fig. 54.—No. 397.

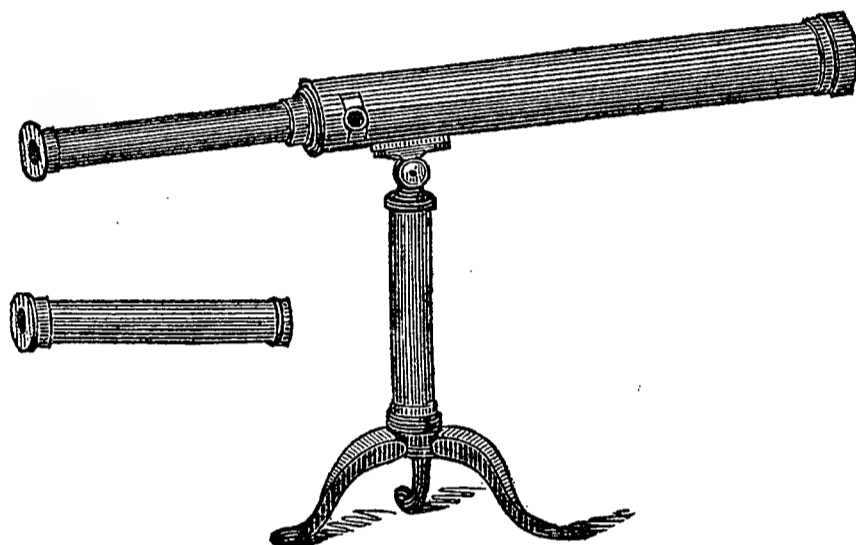
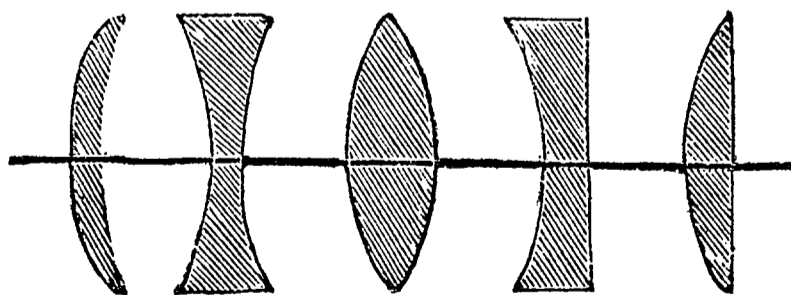

Fig. 54 represents the form of the Astronomical Telescopes, with Terrestrial and Celestial powers and Sun Glass, mounted on tripod stand and rack adjustment. It is entirely of brass, beautifully finished, and for defining power is superior to any imported at the prices. They are very portable, and packed in a neat case. Prices, \$65.00, \$75.00.

MODELS OF LENSES.

Fig. 55.



Price of Sets, from \$4.00 to \$10.00.

No. 437.

SET OF MODELS OF THE HUMAN EYE.

Fig. 56.

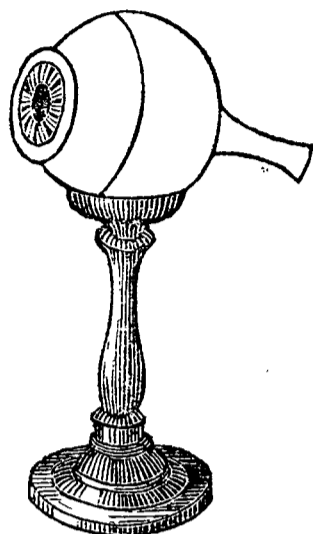

Fig. 57.

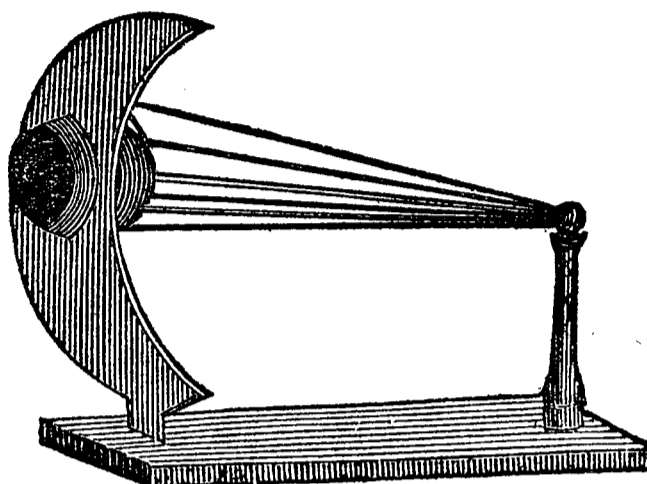
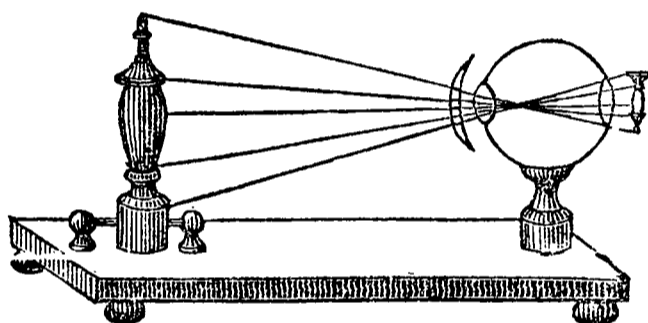

Fig. 58.



The Set of Models of the Eye has been much improved in construction and operation. Fig. 56, represents the Globe of the Eye, containing the various coats and parts which can be successively removed, showing the arrangement of the eye as it appears on dissection. The Globe is 4 inches diameter, and supported upon a stand.

At Fig. 57 is shown the attachment of the muscles, and the manner in which the Eye is moved in the socket.

Fig. 58 shows the form of our Apparatus for illustrating the position of the Image with regard to the Retina, in Perfect, Long, and Short sight. The inversion of the Image by the crossing of the Rays, (shown by silk cords,) is seen much more perfect than in any other construction.

The set is accompanied by an explanatory pamphlet and a large colored Sectional Diagram. Price of set complete, \$12.00.

Set No. 1.

Glass Prism, Flower Microscope, Plain Kaleidascope, Set of 6 Sections of Lenses,	Pair of Convex and Concave Mirrors, Colored Diagram of the Eye.
Price, \$10.00.	

Set No. 2.

Glass Prism, Pair of Mirrors, [56, 57, 58, Set of Models of the Eye, Figs. Brass Kaleidascope,	Set of 6 Sections of Lenses, Botanic Microscope in Box, Colored Diagram of the Eye and Book of Explanation.
Price, \$25.00.	

Set No. 3.

Glass Prism, Set of 2-inch Lenses, Set of 4 Mirrors, Set of Models of the Eye,	Compound Microscope, Carpenter's Telescopic Kalei- dascope.
Price, \$40.00.	

GALVANISM.

The Battery shown on page 36, contains 100 pairs of plates arranged for deflagration. It is entirely made of Mahogany, and is very portable and convenient. The plates being arranged in two cases of 50 pairs each; by removing one of the troughs, or not charging it with the acid solution, but 50 pairs may be used. The Racks also are very durable, and not liable to be injured like cords; the cases with the plates are stationary, and the troughs with the liquid are raised by the Racks. The advantages are, that we thus move the *lightest* portion of the Battery, and the connections are undisturbed, which permits the using of the very convenient Sliding Forceps, for holding substances for deflagration, &c., shown at A, Fig. 59. Price, complete with Sliding Forceps, Apparatus for decomposition of Water and Alkalies, and Handles for Shocks, \$100.00. Batteries with Racks, with 50 pairs of plates, as above, with Apparatus, \$50.00.

WIGHTMAN'S IMPROVED RACK GALVANIC BATTERY.

Fig. 59.—No. 460.

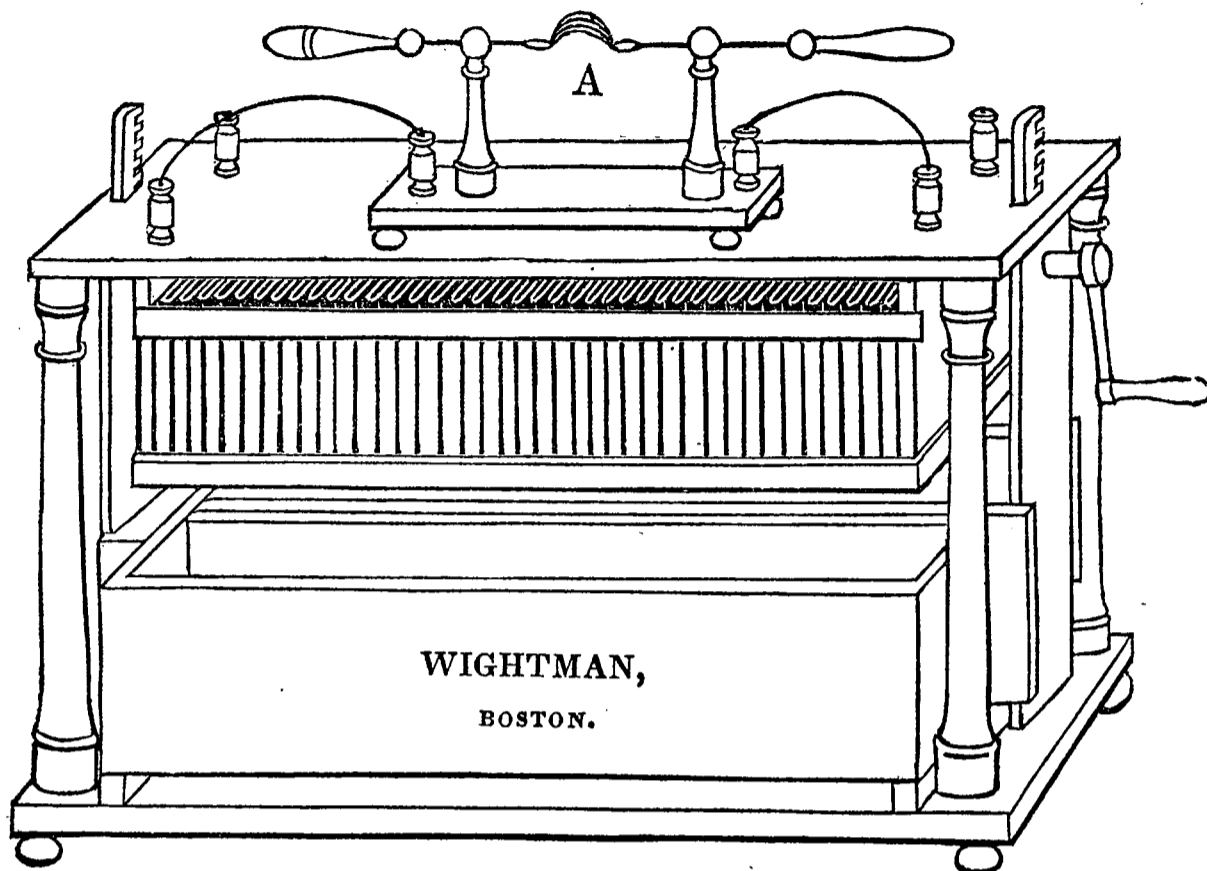
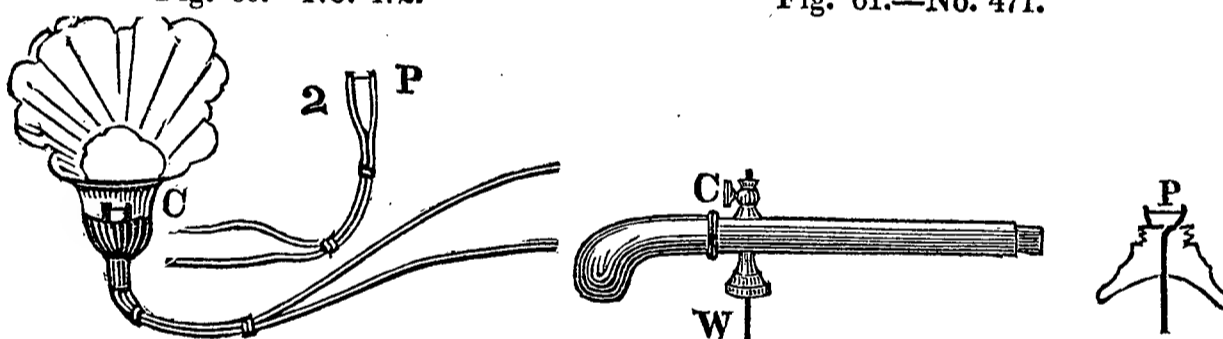

Fig. 60.—No. 472.

Fig. 61.—No. 471.



MAGNETISM.

Set No. 1.

Two U. Magnets, Fig. 63,
Y. Armature, Fig. 62,
Magnetic Needle on Stand,
Fig. 65,
Pocket Compass in Box,

Magnetic Swan and Magnet,
Bar Magnet and Star plate,
Fig. 64,
Box of Steel Filings, and Glass
Plate.

Price, \$5.00.

Set No. 2.

Compound Magnet and Y. Ar-
mature, Fig. 62,
Magnetic Needle on Stand,
Fig. 65,
Bar Magnet and Star plate,
Fig. 64,

Pocket Compass in Box,
Magnetic Swan,
Rolling Armature and Magnet,
Fig. 66,
Box of Steel Filings and Glass
Plate.

Price, \$10.00.

Fig. 62.—No. 482.

Fig. 63.—No. 474.

Fig. 64.—No. 483.

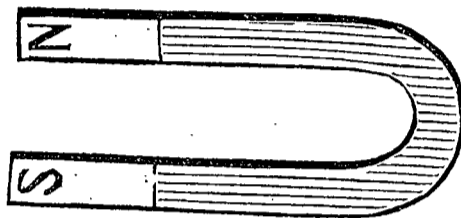
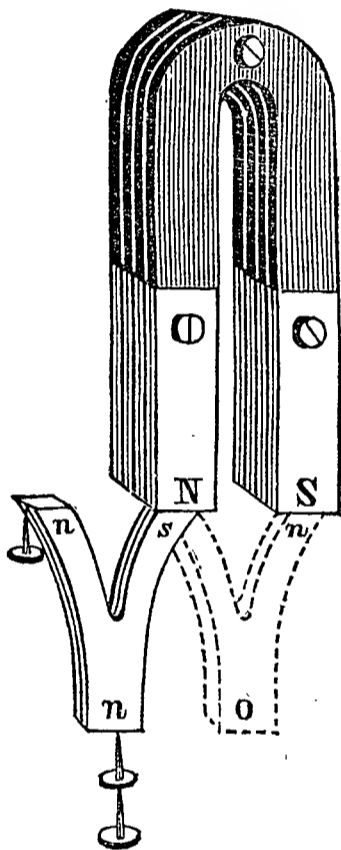

Fig. 65.—No. 477.

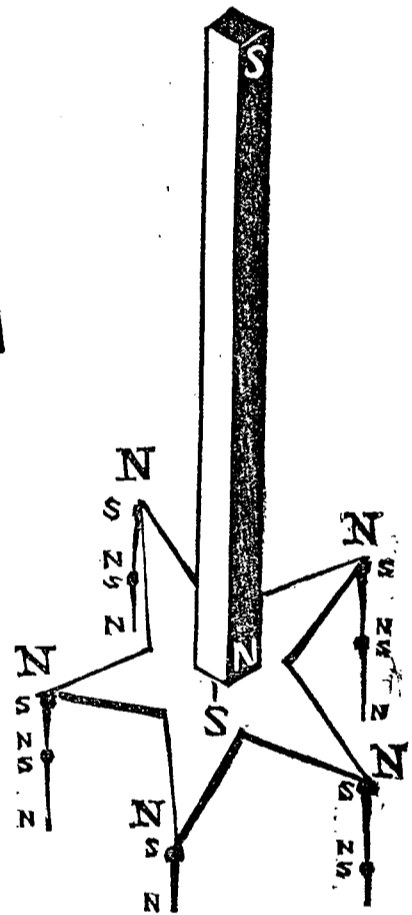
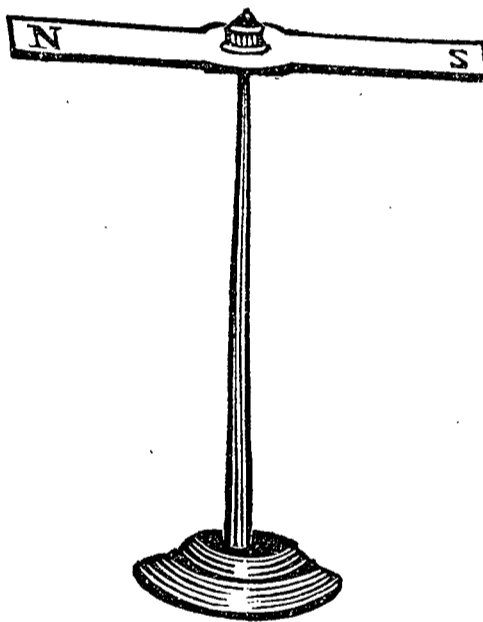
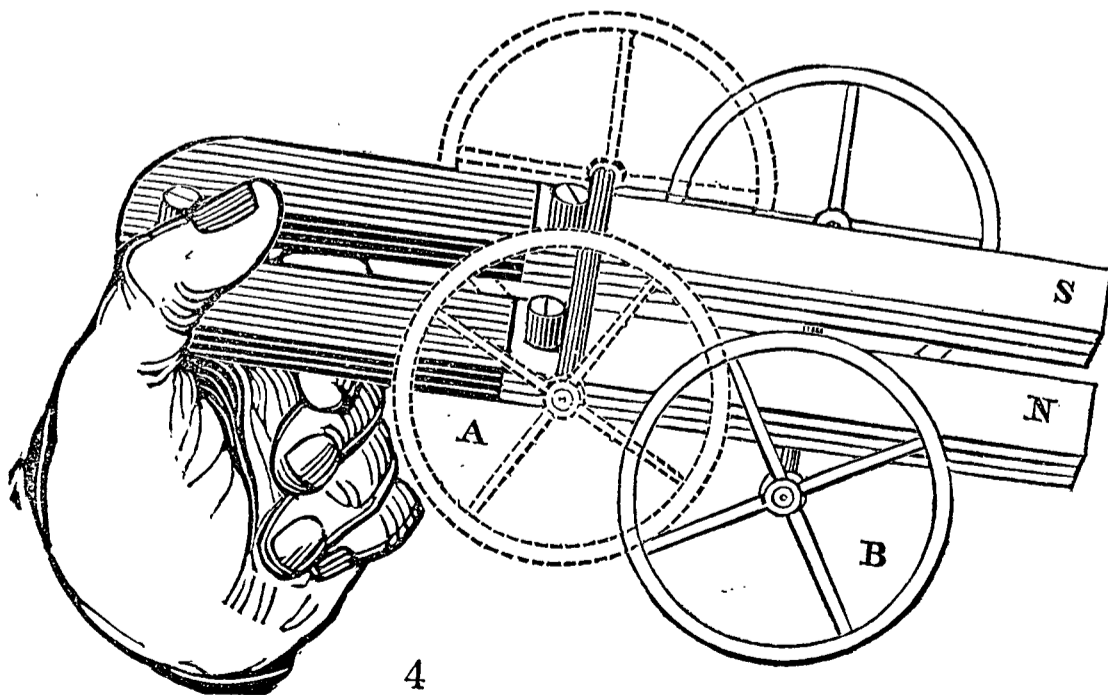

Fig. 66.—No. 484.



ELECTRO-MAGNETISM.

Fig. 67.

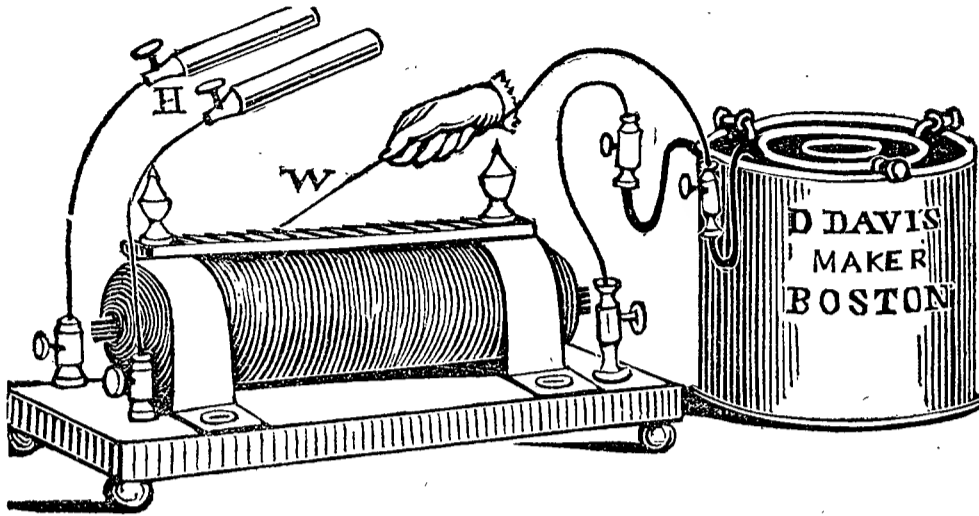

Fig. 68.—No. 490.

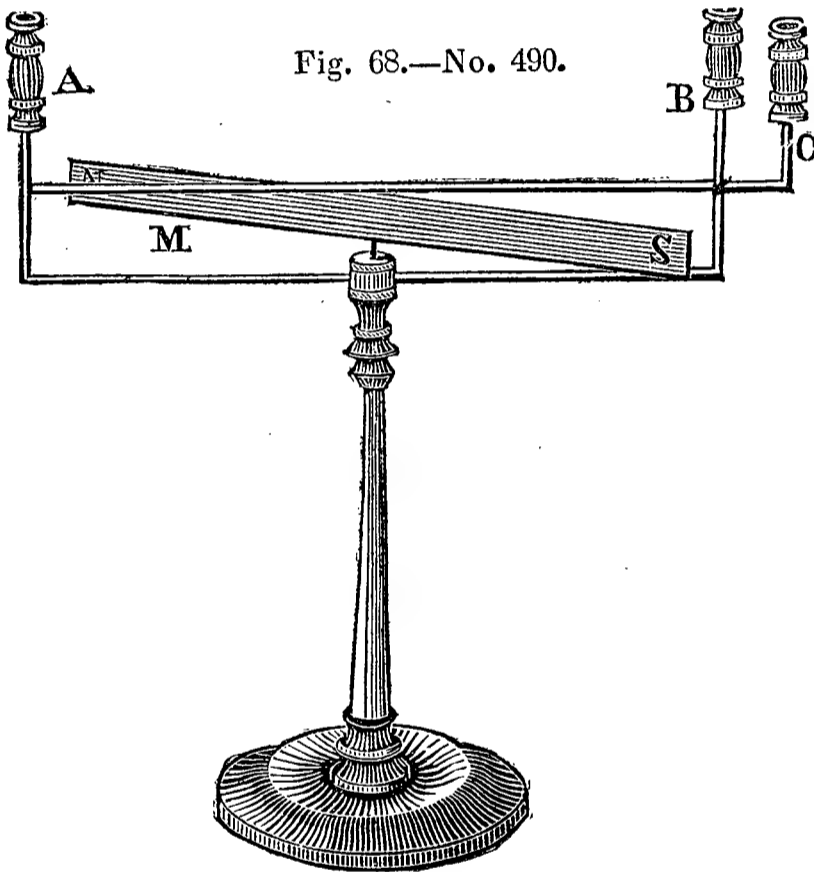

Fig. 69.—No. 518.

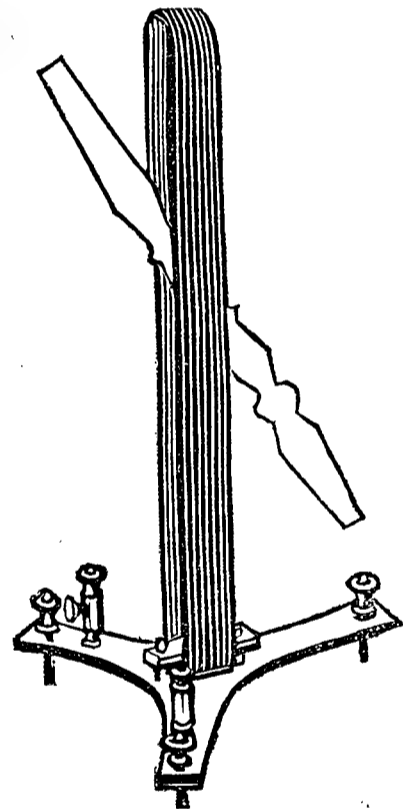

Fig. 70. No. 491.

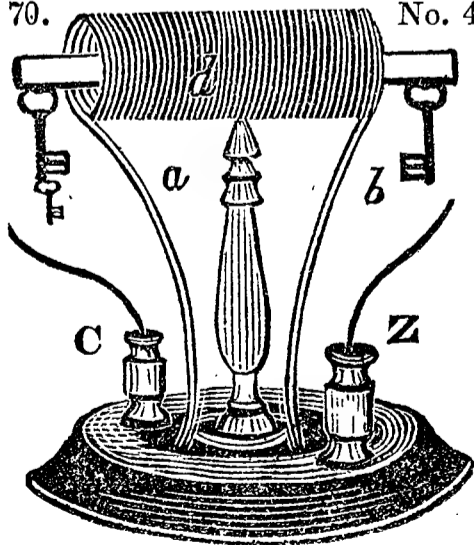
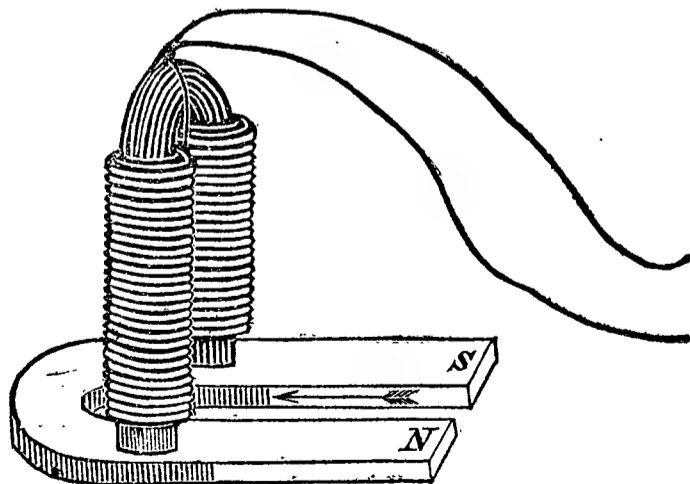

Fig. 71.—No. 495.



ELECTRO-MAGNETISM.

Fig. 72.—514.

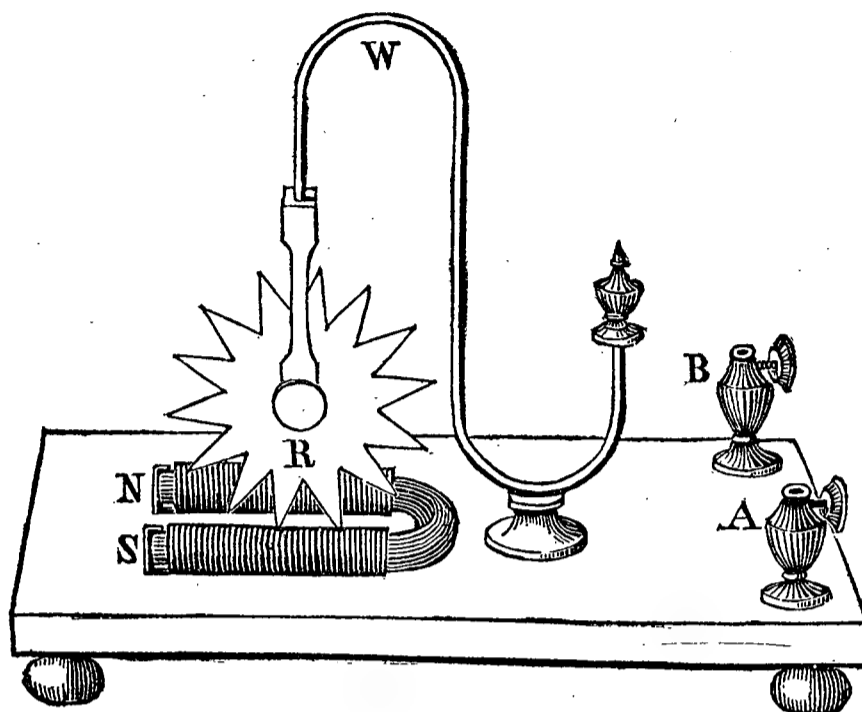

Fig. 73.—No. 502.

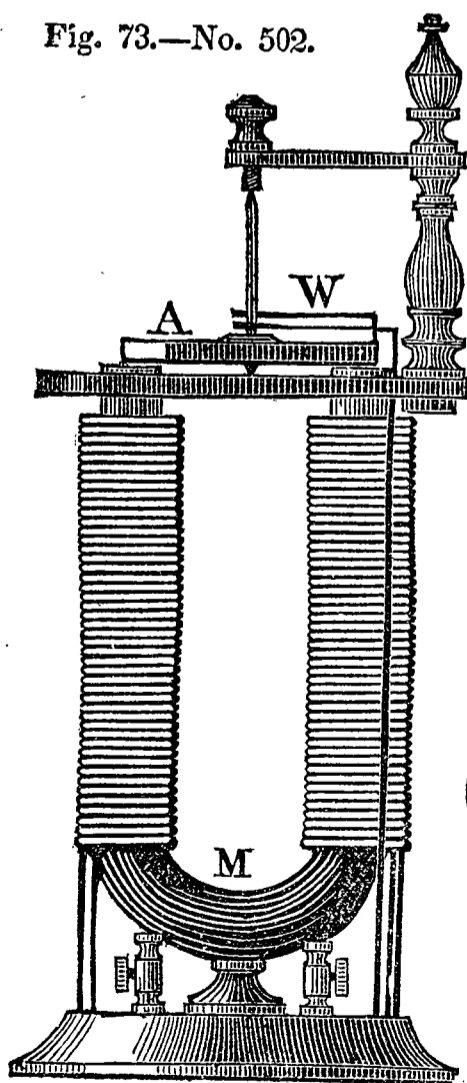

Fig. 74.—No. 494.

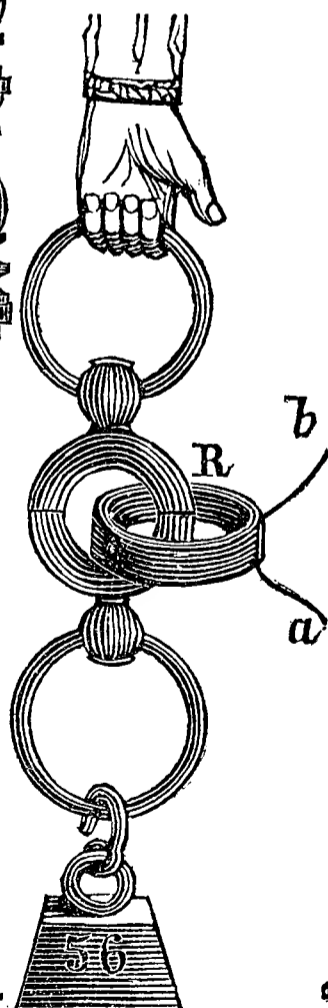
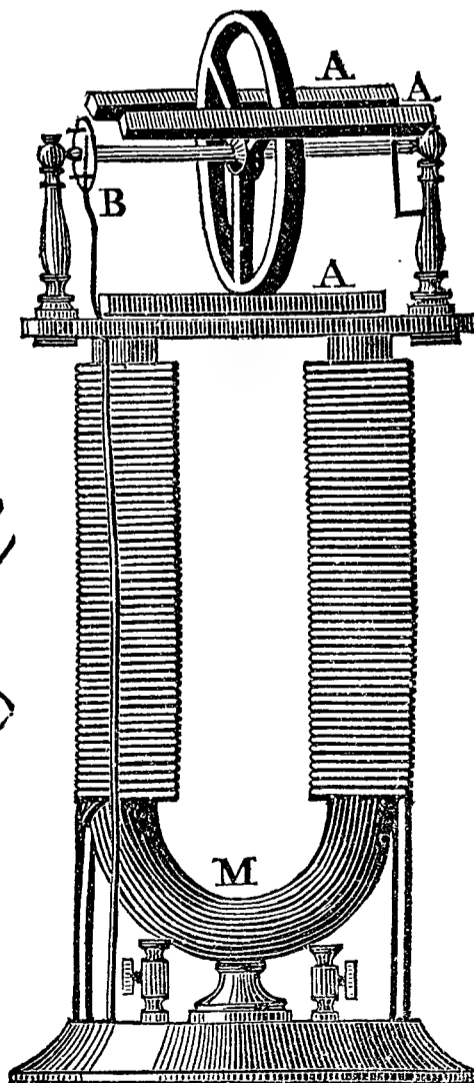

Fig. 75.—No. 507



ELECTRO-MAGNETISM.

Fig. 76.—No. 501.

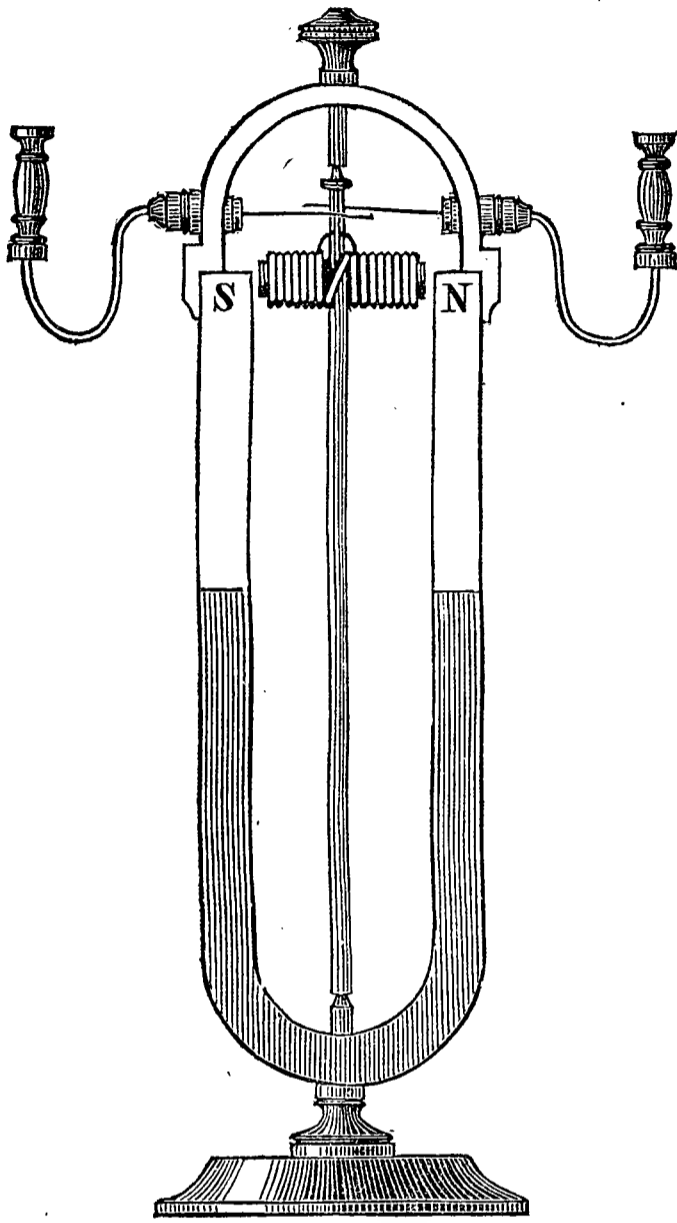

Fig. 77.—No. 506.

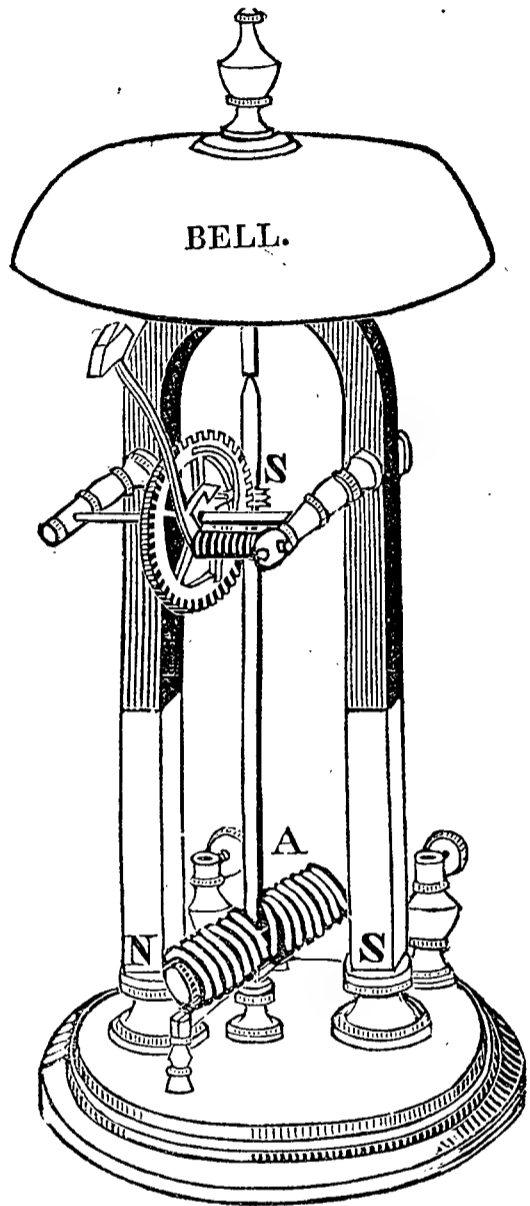

Fig. 78.—No. 513.

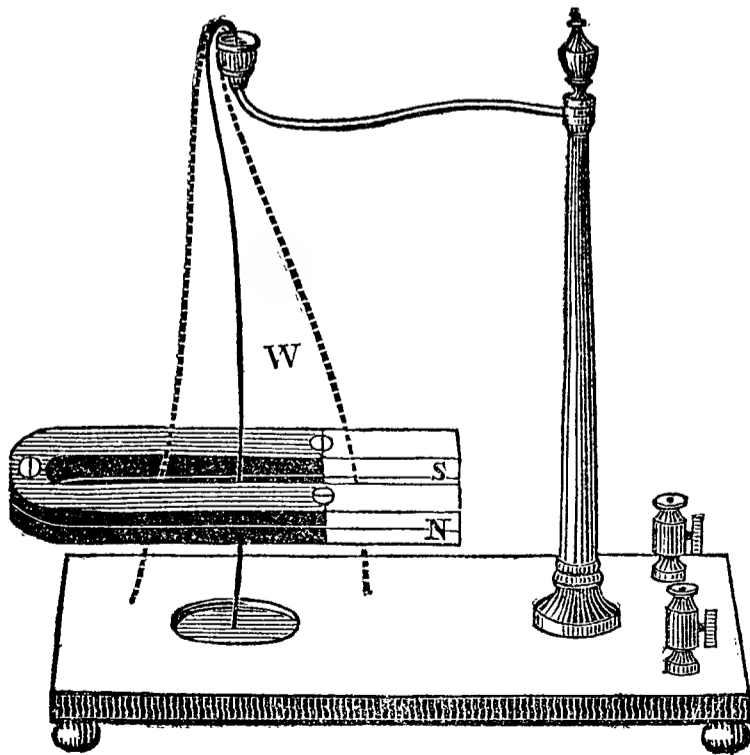
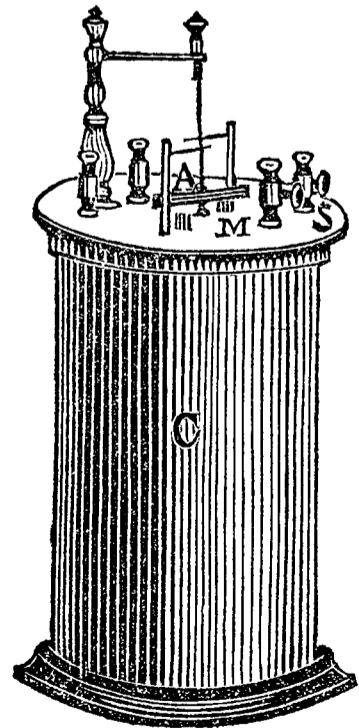

Fig. 79.—No. 503.



ELECTRO-MAGNETISM.

PAGE'S COMPOUND MAGNET AND ELECTROTOME.

Fig. 80.—No. 521.

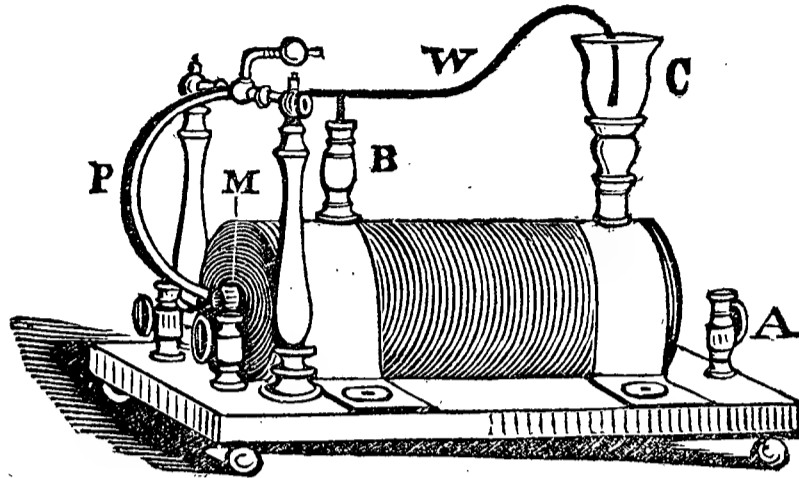
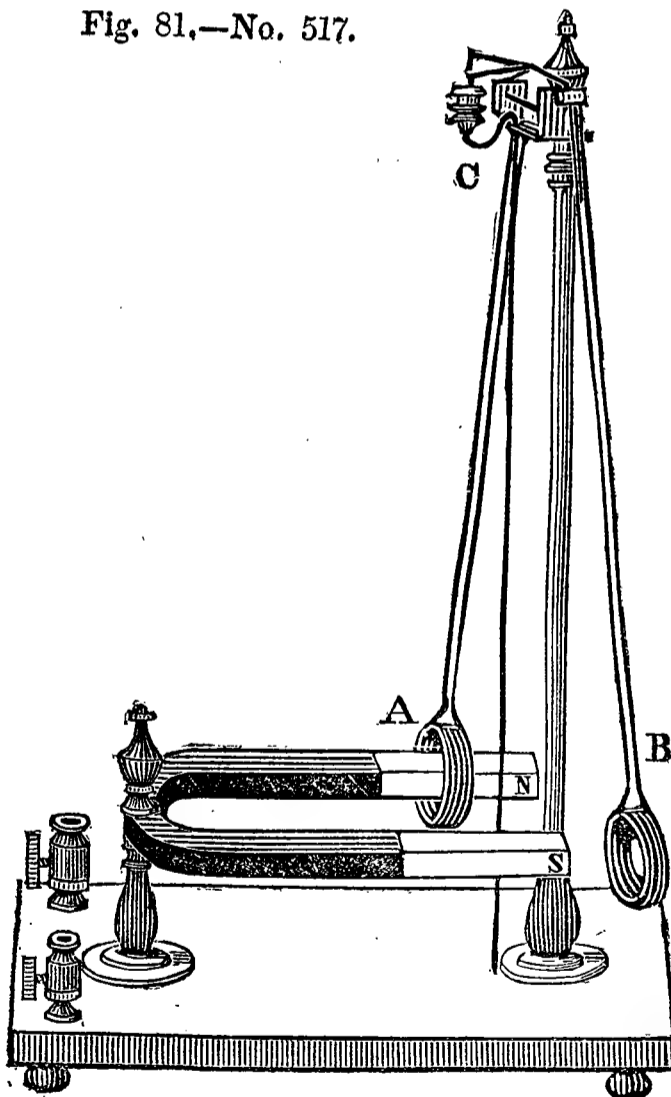
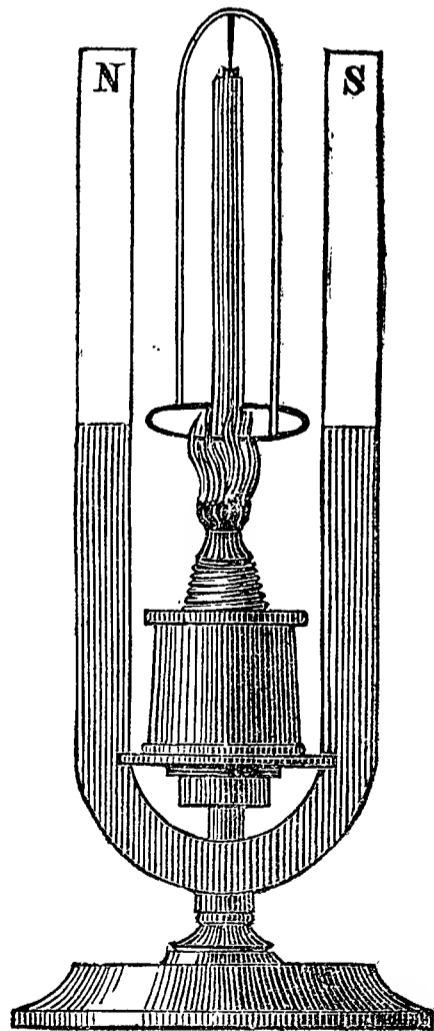

Fig. 81.—No. 517.



THERMO-ELECTRICITY.

Fig. 82.—No. 530.



ELECTRO-MAGNETISM.

Fig. 83.—No. 499.

ANALYTICAL APPARATUS.

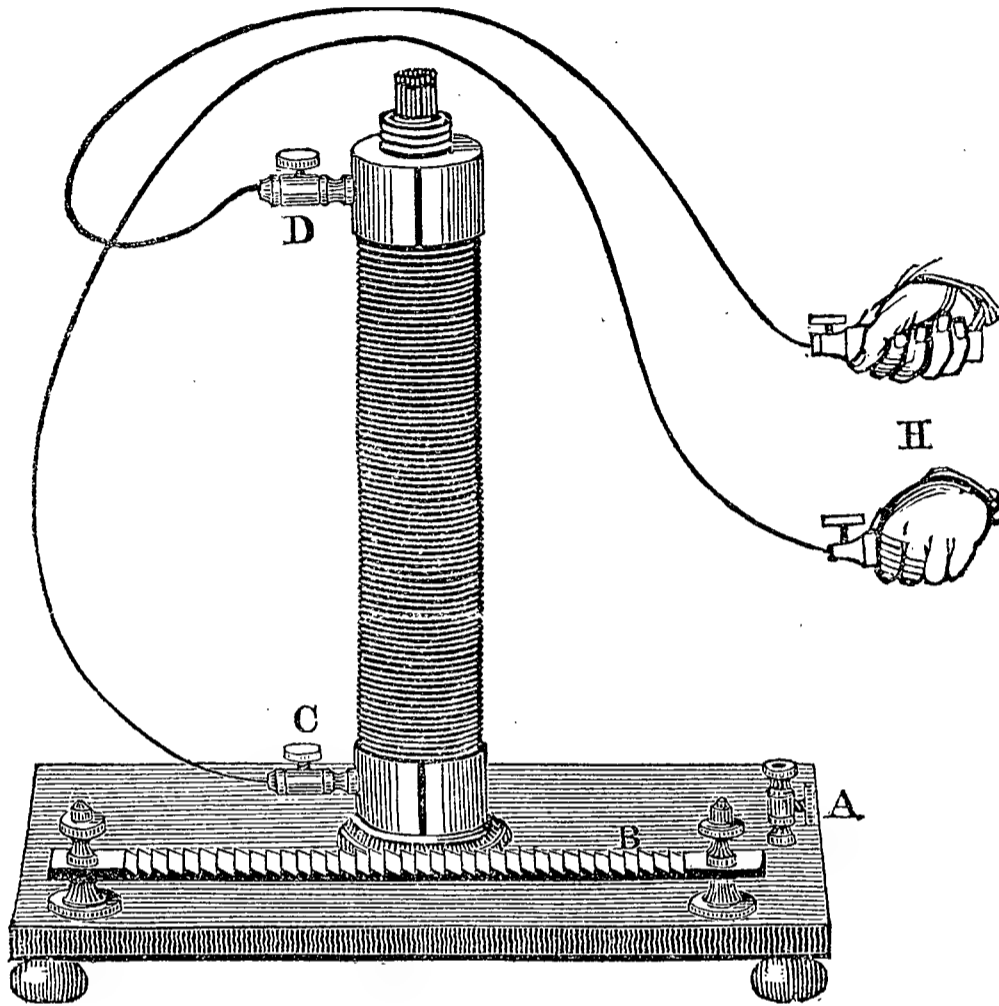

MAGNETO-ELECTRICITY.

Fig. 84.—No. 527.

MAGNETO-ELECTRIC MACHINE.

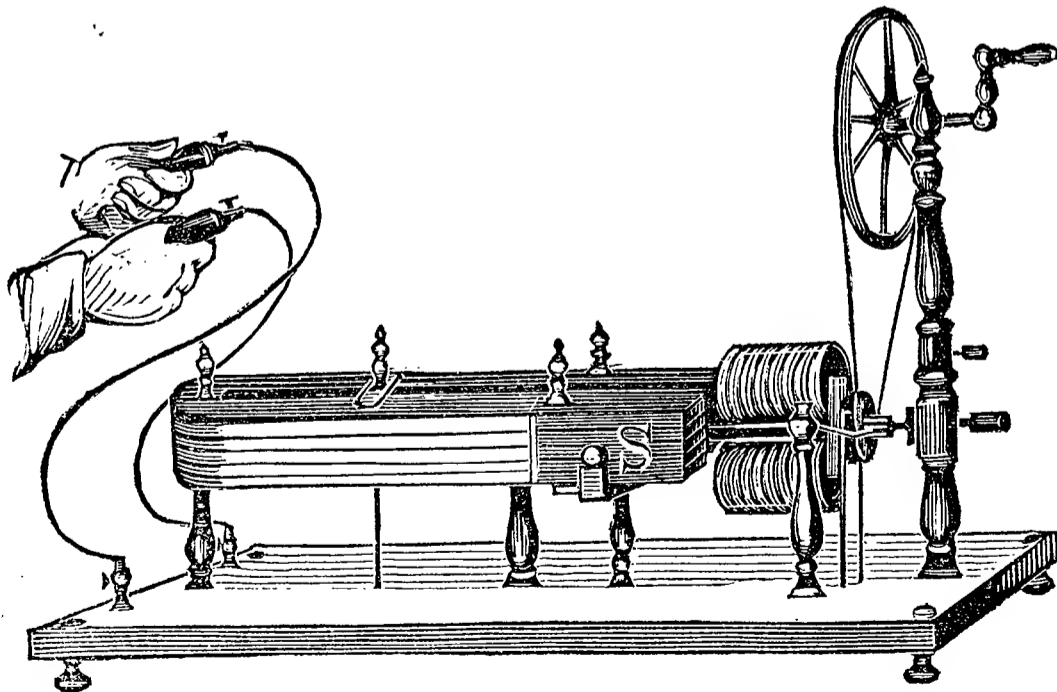

Set No. 1.

Medical Coil on stand, Battery and Wires,	Pair German Silver Handles.
--	-----------------------------

Shown entire at Fig. 67. Price \$10.00.

Set No. 2.

Cylindrical Battery, small size, at Fig. 67, Electro Magnet and U. Magnet, Fig. 71, Needle on Stand, Fig. 65,	Magic Coil and Armatures, Fig. 74, Page's Compound Magnet and Electrotome, Fig. 80.
---	--

With "Manual." Price \$15.00.

Set No. 3.

Battery, (Medium size,) Electro and U. Magnet, Fig. 71, Analytical Apparatus, Fig. 83, Oersted's Galvanometer, Fig. 68, Helix on Stand, Fig. 70.	Magic Coil and Armatures, Fig. 74, Pair German Silver Handles, Magnetic Needle on Stand, Fig. 65.
---	---

With "Manual." Price \$30.00.

Set No. 4.

Battery, (large size,) Horizontal Galvanometer, Analytical Apparatus, Fig. 83, Page's Revolving Magnet, Fig. 76, Pair Handles for Shocks,	Magic Coil and Armatures, Fig. 74, Upright Bell Engine, Fig. 77. Electro Magnet on Stand with U. Magnet.
--	--

With "Manual." Price 50.00.

ASTRONOMY.**ORRERY.**

Fig. 85.—No. 532.

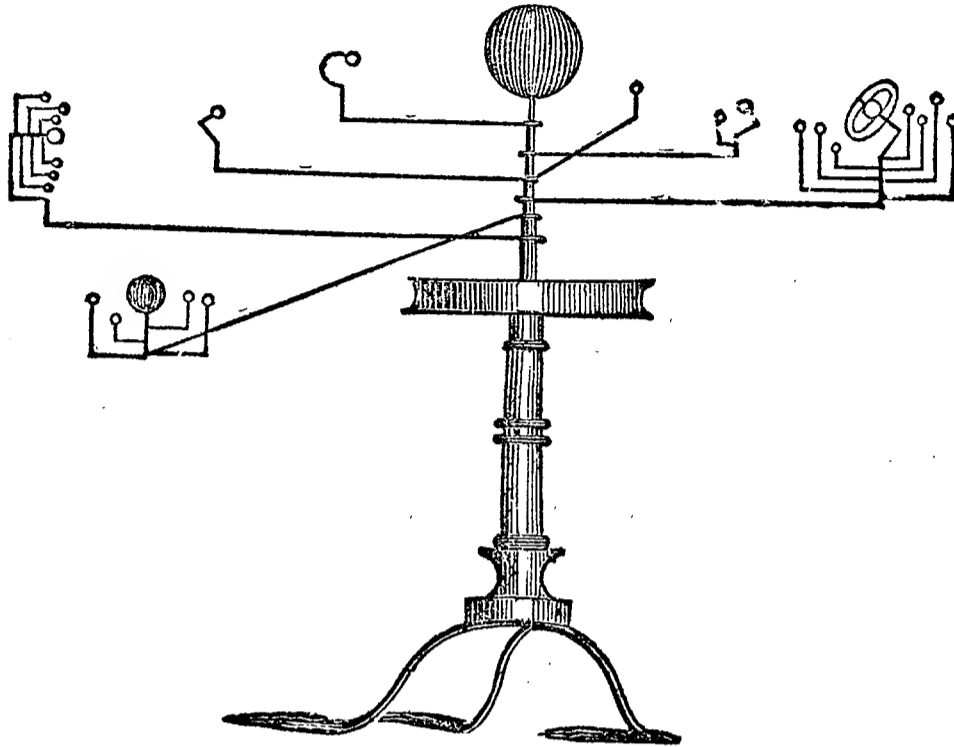
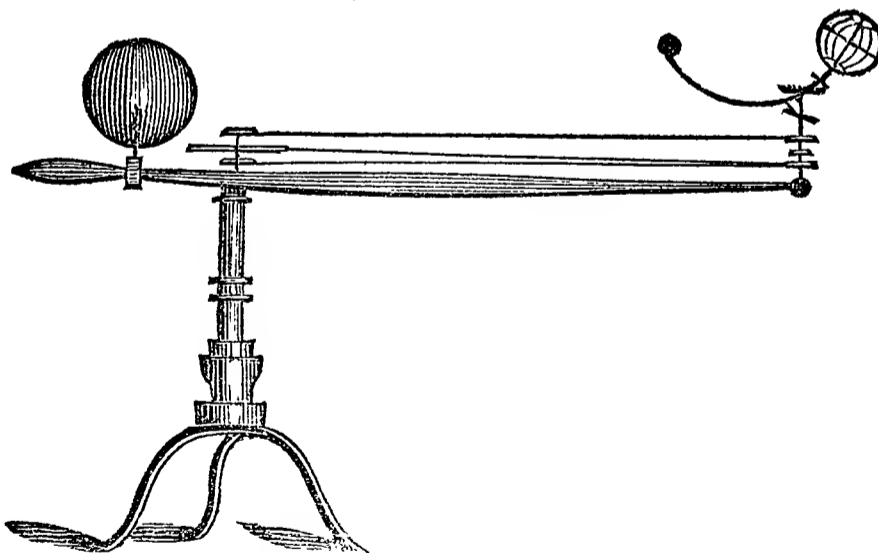

Fig. 85 shows the form and construction of an improved Orrery mounted upon a Brass stand, with gilt Sun. The motions of the primary planets are relatively correct with regard to their times of revolution round the sun. The earth also revolves upon its axis, and the moon around the earth. The gearing is of Brass, and the zodiac is movable, that the wheel-work may be seen. Price \$25.00.

TELLURIAN.

Fig. 86.—No. 535.



At Fig. 86 is shown a Tellurian, mounted upon a Brass stand, and corresponding in form with the Orrery. It is very neat, and being of Brass, is very durable and efficient. All the phenomena of the Seasons, and cause of Eclipses, are easily illustrated. Price \$12.00 and \$15.00.

TIDE DIAL.

Fig. 87.—No. 537.

This Instrument is 15 inches square, and by turning a crank on the back, illustrates the daily change in the Tides; the diurnal motion of the Earth; the cause of Eclipses; and the *umbra* and *penumbra* of the Earth. The larger circle indi-

cates the number of days in the lunar month, and the smaller circle, the 24 hours of the days.

This is the most correct Tide Dial made, and is very neat in construction, being mounted upon a mahogany stand, with a gilt sun, and Brass wheel-work.

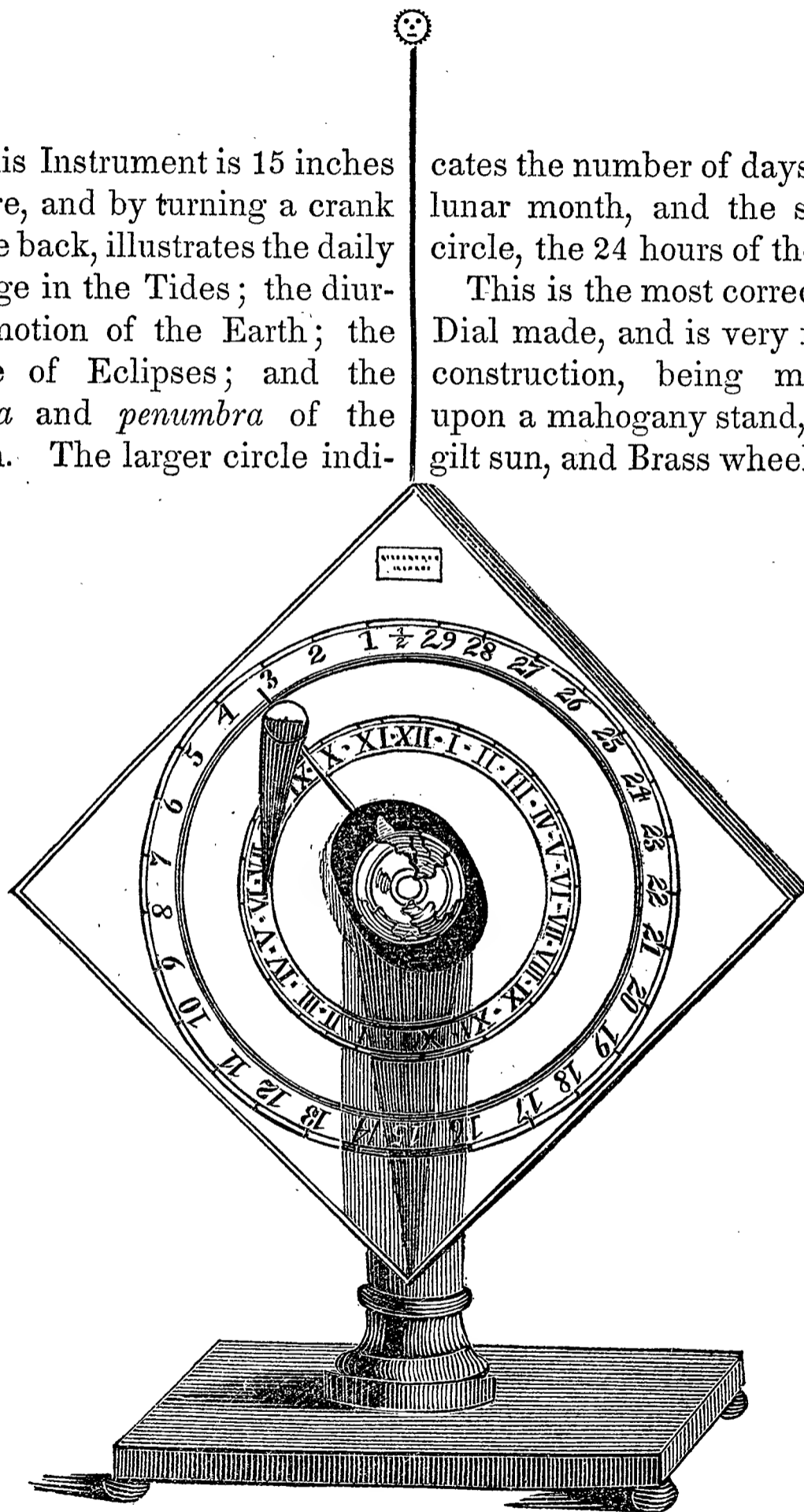

Price \$6.00.

GEOGRAPHY.

JOSLIN'S METAL FRAME GLOBE.

Fig. 88.—No. 543.



This drawing is from a new Globe stand, as designed for Loring's 12 and 9-inch Globes; being of Metal, the centre of gravity is very low, and the spread of the tripod is so great that it can only be overturned by design. It has been very desirable to have a Globe stand of sufficient height to be easily examined and moved before the pupils of an entire class; mounted upon wood stands this could not be done without great care; but in the present, it can be pushed about by even the top of the Globe, (however carelessly,) without any possibility of being overturned. Mr. Joslin has accomplished the object in a substantial, light, and beautiful manner. The stand is bronzed, and besides being more rich in appearance than the wood frames, is also of less cost. Price for pair 12-inch, \$40.00.

GEOMETRY.

NUMERAL FRAME.

Fig. 89.—No. 571.

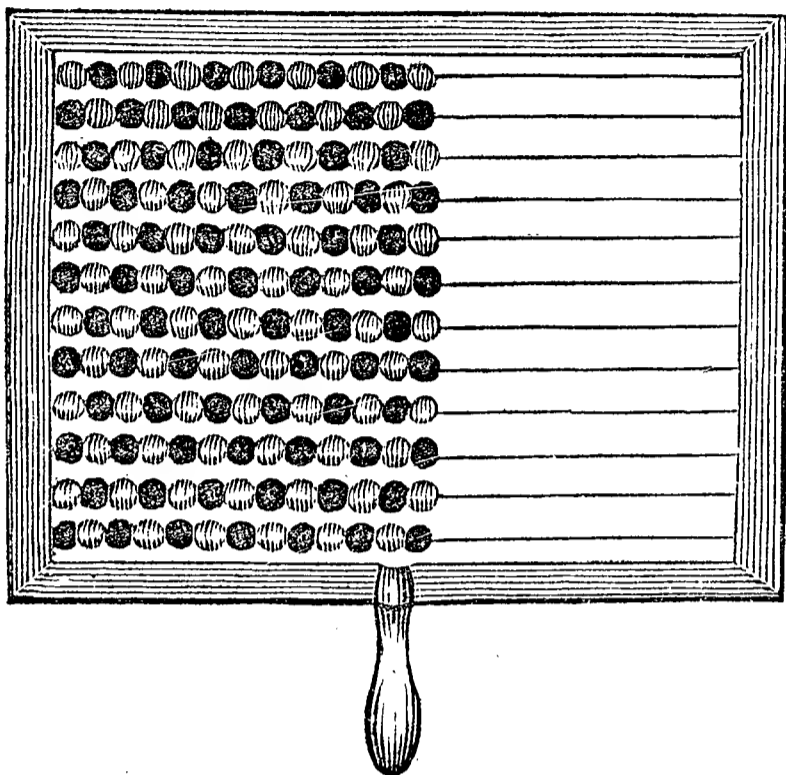

DISSECTED CONE.

Fig. 90.—No. 574.

MECHANICAL ILLUSTRATION OF
THE 47th PROB. OF EUCLID.

Fig. 91.—No. 583.



BOX OF 64 CUBES.

Fig. 92.—No. 573.

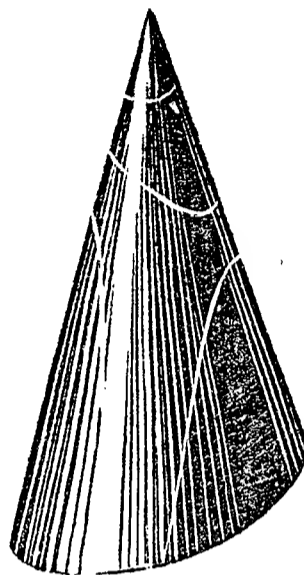
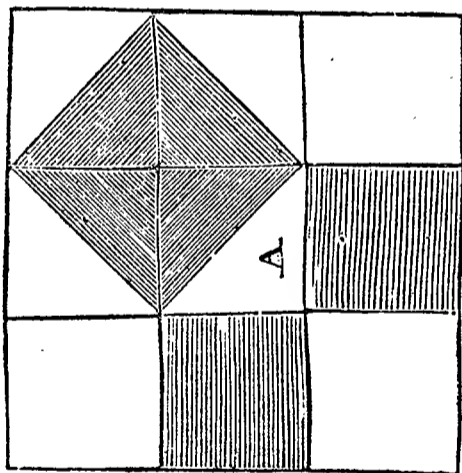
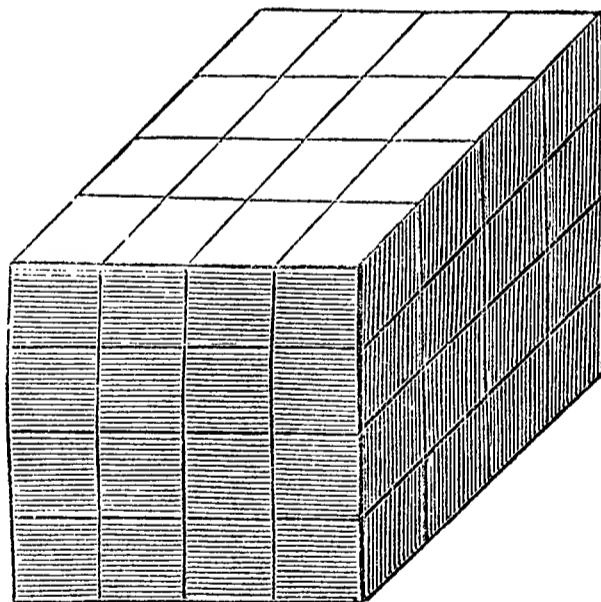
**SET OF PRIMARY SCHOOL APPARATUS.**

Numeral Frame, Fig. 89,
Suspension Orrery,
Set 13 Geometrical Solids,
Outline Map of World,
" " " United States,
Arithmometer,

5-inch Globe,
Set of 9 Parallelepipeds,
" " Tin Frames for angles,
Plate of Solar System,
" " Manuscript Letters,
" " Geometrical Figures.

Price, \$6.00.

LIST OF ASTRONOMICAL DIAGRAMS,

FOR CARPENTER'S IMPROVED PHANTASMAGORIA LANTERN.

SLIDE I.

1. The Sun.
2. Mercury.
3. Venus.
4. Earth.

SLIDE II.

5. Mars.
6. Asteroids.
7. Jupiter.
8. Saturn.

SLIDE III.

9. Herschel.
10. New Moon.
11. Moon's Quadrature.
12. Full Moon.

SLIDE IV.

13. System of Ptolemy.
14. System of Copernicus.
15. System of Tycho Brahe.
16. System of Newton.

SLIDE V.

17. Comparative Size of the Planets.
18. Comparative Distances of the Planets.
19. Orbit of a Comet.
20. Comet of 1811.

SLIDE VI.

21. Rotundity of the Earth, (movable.)

SLIDE VII.

22. Signs of the Zodiac.
23. Inclination of the Orbits of the Planets.
24. Direct and Retrograde Motion.
25. The Seasons.

SLIDE VIII.

26. Phases of the Moon.
27. Earth's Shadow.
28. Cause of the Sun's Eclipse.
29. Cause of the Moon's Eclipse.

SLIDE IX.

30. Eclipse of the Sun, (movable.)

SLIDE X.

31. Moon's Eclipse, (movable.)

SLIDE XI.

32. Inclination of the Moon's Orbit.
33. Spring Tide at New Moon.
34. Spring Tide at Full.
35. Neap Tide.

SLIDE XII.

36. Constellation Orion.
37. Ursa Major, Great Bear.
38. Various Nebulæ.
39. Milky Way.

CATALOGUE AND PRICES

OF

PHILOSOPHICAL APPARATUS

MANUFACTURED AND SOLD BY

JOSEPH M. WIGHTMAN,

No. 33 CORNHILL, BOSTON.

PROPERTIES OF MATTER.

No.		
1.	Inertia Apparatus,	\$1.50
2.	Set of Apparatus for Attractions, viz: Gravitation, Cohesion, Capillary, Electric and Magnetic,	5.00
3.	The above of larger size,	10.00
4.	Glass Tube, showing that a tube enlarged at the end does not affect the Capillary Attraction,25
5.	A pair of Lead Hemispheres, with handles for showing Co- hesion, 25 cts., 50 cts., and	1.50
6.	A pair of Brass Plates, with handles for Cohesion, \$2.00, 3.00	4.00
7.	Circular Glass Plate, for suspending from Scales upon water, to show the force of Cohesion, \$1.00 to	5 00

MOTION.

8.	Atwood Machine, for Laws of falling bodies, with Friction wheels; various weights, and Clock movement,	50.00
9.	Apparatus for illustrating all the principles of the Laws of fall- ing Bodies as clearly as the Atwood Machine,	15.00
10.	A set of six, one and a half inch Ivory Balls, suspended from a frame with graduated arc, for Laws of Collision and Per- cussion,	8.00
11.	A set of six, one and a half inch Boxwood Balls, on Ma- hogany stand,	3.00
12.	A set of five Boxwood Balls, on plain Mahogany stand,	2.00
13.	A set of " " " without stand,	1.00
14.	A set of eight illustrations for Centre of Gravity, viz: 1, 2, 3, Blocks of various figures, with centres of gravity and sus- pension; 4, two Balls on rod, with centre of gravity; 5,	

No.	Leaning Tower of Pisa, with two centres of gravity: 6, Loaded Wheel on Stand, with centre of gravity and magnitude; 7, Mechanical Paradox; a double cone <i>appears to roll up hill</i> ; 8, Horseman, or Rope Dancer, balanced on <i>two points</i> . This set also includes a Brass Plumb, Cord and Handle for supporting the various articles on centre of gravity. Price of set,	\$7.00
15.	A cheaper set, viz: Three Blocks for suspension; Block for centre gravity and magnitude; plain Leaning Tower; Mechanical Paradox; Bowing or Prancing Figure, with Plumb and Handle. Price of set,	4.00
16.	The Philosophical Waltzers. Two beautiful little figures are attached to a Glass Lens, which when placed upon a <i>clean wet plate</i> , and the plate <i>inclined</i> , the figures have a rotary, progressive motion, illustrating centre of gravity,75
17.	Apparatus for Central and Centrifugal Forces. This illustrates in a beautiful manner the cause of the Planets revolving on their shortest diameter; the cause of their being flattened at the poles; the peculiar effect of rapid rotation upon the loose parts of a body; and a variety of other pleasing effects, with seven Illustrations, more complete than the London Apparatus, at £5,	7.00
18.	Apparatus to Illustrate the Brachystochrone, or line of swiftest descent; six feet in length, made of Mahogany, with two Agate Balls,	10.00
19.	Apparatus to show the Synchronous descent on the chords of a circle,	6.00
20.	Model of Cycloidal Pendulum, \$3.00	5.00
21.	Sliding Jointed Parallelogram, for illustrating the equilibrium of forces, \$3.00 to	6.00
22.	Sliding Frame, for showing the resultants of simple and compound forces,	2.00

MECHANICS.

23.	Mechanical Powers, with four sets of Brass Pulleys, Counterpoises, Brass and Japanned Weights; Wheel and Axle on frame: Simple and Compound Levers of Brass, with Weights; Inclined Plane, with Carriage and Weight; Wedge in two parts; Screw on Frame. The whole are mounted on Mahogany Stands with turned pillars, making a very complete Apparatus for High Schools and Academies, Figs. 2, 3, 4, 5, 6,	25.00
24.	Mechanical Powers, with five sets of three-inch Pulleys, Counterpoises and Weights, on Mahogany frame, with turned pillars, Fig. 7. Wheel and Axle on separate stand, with	

- | | | |
|-----|---|---------|
| No. | Pulley and Weights for Chinese or Compound Axle; Brass Compound Levers, one to one hundred and twenty, with Weights on stand; Simple Lever of Brass, for showing first, second, and third kinds of Levers; Screw, with Movable Lever; Wedge, in three parts; Inclined Plane; Carriage and Weights. Price of set, | \$50.00 |
| 25. | Mechanical Powers, with six sets of three-inch Pulleys, Weights and Counterpoises, with Model of a Ship's Capstan, on Mahogany frame; Wheel and Axle, Simple and Compound; Simple Lever of Brass, with Weights; Lever arranged with Pulleys for second and third kinds; Compound Levers on stand with Weights; Endless Screw; Screw, with Movable Lever; Train of Geered Wheels; Inclined Plane, Carriage and Weight, and Wedge. Price, | 75.00 |

HYDROSTATICS.

- | | | |
|-----|--|-------|
| 26. | A Steel Beam Balance, with Troy Weights from one half a grain to four ounces, mounted on a Lever stand; Glass Hydrometer; two Glass Jars, and six Illustrations for specific gravity, \$10.00 and | 12.00 |
| 27. | A Steel Beam Balance, larger and more delicate, mounted upon a Mahogany Lever stand, with Troy Weights, from one tenth of a grain to eight ounces; two Glass and one Metal Hydrometer; a Glass Ball, for taking specific gravity of liquids with scales; a Brass Apparatus for showing that all bodies lose the <i>weight</i> of an equal bulk of the fluid in which they are immersed; a Brass and Glass Cup, with Counterpoises for holding bodies; two Glass Jars, and eight Illustrations. Price of set, | 25.00 |
| 28. | A Glass Globe, with Stop Cock, for weighing air or gas with above, | 1.50 |
| 29. | A Copper Flask, with Stop Cock, for weighing, \$3.00 to | 4.00 |
| 30. | Glass Hydrometers, for acids or alcohol, from 50 cts. to | 1.50 |
| 31. | “ “ Improved, for illustration. The zero or water point is in the centre of the scale, and may be used for acids or alcohol, in box, | 1.50 |
| 32. | Tall Glass Jars, with foot and lip, for Hydrometers, 63 cts., 75 cts., and | 1.00 |
| 33. | Superior Hydrostatic Bellows, of Brass and Mahogany, Fig. 10, | 5.00 |
| 34. | Duplicate India Rubber Bags for above, 75 cts. to | 1.00 |
| 35. | Hydrostatic Bellows and Paradox combined, nine by twelve inches, of Mahogany, with Vessels, Tubes and Scale, Fig. 8, | 10.00 |
| 36. | Duplicate India Rubber Bags for above, adapted for a stop cock, and may be used for a gas bag, \$1.25 and | 1.50 |

No.		
37.	Hydrostatic Paradox, illustrating that pressure is according to height, not quantity, \$5.00	\$10.00
38.	Apparatus for upward and downward pressure of Fluids, Fig. 14,	2.00
39.	Fluid Level Apparatus, with various formed vessels, \$2.00 to	4.00
40.	Glass Apparatus for Fluid Level,	1.50
41.	Spirit Levels, with adjusting Screws for illustration, \$2.00 to	4.00
42.	“ “ in Brass, with box for the pocket, \$2.00, 2.50, 4.00,	5.00
43.	Spirit Levels, not mounted, 25 cts. 50 cts. 75 cts. and	1.00
44.	Model of Diving Bell of Glass, \$1.00, 1.50, and	3.00

HYDRAULICS.

45.	An Operating Model of the Forcing Pump, illustrating also the Fire Engine, on stand,	7.00
46.	Operating Model of the Lifting or Household Pump, with Glass Barrel, on stand,	6.00
47.	Both the above on one stand, with water vessels,	12.00
48.	A cheaper Model of the Lifting Pump,	4.00
49.	Model of Archimedes' Screw Pump, all of metal, with Jet, . .	5.00
50.	Glass Syphon Cup, for illustrating intermitting springs, Fig. 12,	1.50
51.	Glass Syphon Cup, with figure of Tantalus,	3.00
52.	A larger Apparatus for illustrating intermitting springs, \$5.00.	6.00
53.	Hero's Fountain, which jets above its source, (of copper,) . .	5.00
54.	“ “ with glass vessels, in which the operation is distinctly seen, \$10.00 to	15.00
55.	Apparatus for the Spouting of Fluids, \$5.00, 10.00, 20.00,	25.00
56.	Operating Model of Hydraulic Press, \$15.00 to	50.00
57.	Glass Syphon Tube, three feet long, with Stop Cock for law of Marriote and other experiments, \$3.00 to	4.00
58.	Wirtemberg Syphon of Glass, 38 cts.75
59.	Common, “ “ “ 25 cts. to38
60.	Syphon of Glass, with Jet, 38 cts.50
61.	“ “ “ with Suction Tube,	1.00
62.	“ of Brass, or Block Tin,	1.00
63.	“ Fountain on stand, \$10.00 to	20.00
64.	Model of Centrifugal Pump,	10.00

STEAM.

65.	Sectional Model of the Steam Engine, Fig. 15, with twelve-inch Beam,	12.00
66.	Sectional Model, with eighteen-inch Beam, and more complete,	25.00
67.	Operating Models of Steam Engines, from \$50.00 to	60.00

No.	Operating Models of Watts' Low Pressure Steam Engine. The Condensing Apparatus is contained in a box with glass sides, that the operation may be seen. The whole enclosed in a Mahogany and Glass case,	\$250.00
68.	Eolipile, or Steam Ball of Brass, Fig. 48,	1.50
69.	A Revolving Jet for Eolipile,	1.00
70.	Glass Eolipile for Ether,50
71.	Wollaston's Small Glass Apparatus for illustrating the Condensing Steam Engine, \$1.50	2.00
72.	Marcet's Steam Globe, for showing the elastic force and temperature of Steam, at pressures above that of the atmosphere, \$12.00	15.00
73.	A Wheel with Jet, to attach to Steam Globe, \$1.50 to	2.00
74.	A Revolving Jet, " " " " "	1.00
75.	Steam Locomotive Engine Whistle, " 75 cts. to	1.00
76.	A Cylinder and Apparatus to attach to Steam Globe, to illustrate Newcomen's Engine,	4.00
77.	Small Brass Steam Globe, with Stop Cock, Steam Wheel, Revolving Jet, Whistle, and Spirit Lamp,	8.00
78.	Revolving Steam Jet of Glass, complete in itself, 50 cts.75

PNEUMATICS.

AIR PUMPS.

79.	"Leslie's" Air Pump, with Wightman's Improved Guards, Fig. 26,	150.00
80.	Wightman's Patent Lever Air Pump, on High stand, for exhausting, condensing, and transferring, Fig. 25,	75.00
81.	Improved Table Pump, on stand like Fig. 25, for exhausting,	60.00
82.	Claxton's " " for exhausting, Fig. 24,	50.00
83.	Wightman's Patent Portable Air Pump, Fig. 23,	45.00
84.	Claxton's, " " " " " 22, enlarged and improved,	25.00
85.	Single Barrel Air Pump on stand, with two Bell Receivers,	12.00
86.	Small Air Pump for exhausting and condensing, with plate attached, with Jar Receiver, Fig. 17,	6.00
87.	Small Brass Air Pumps for exhausting, \$3.00 to	5.00
88.	" " " " " condensing, \$3.00 to	5.00
89.	" " " " " which, on reversing the valves, are adapted for exhausting or condensing at pleasure, \$5.00 to	7.00
90.	Superior Condensing Apparatus, with two Syringes, Brass Plates, Strong Glass Receivers, and improved arrangement for holding the Receiver under high pressure, mounted upon Mahogany stand, \$30.00 to	50.00

APPARATUS FOR AIR PUMPS.

No.		
91.	Guinea and Feather Apparatus, with Tall Receiver and Brass Plate, with four drops or falls, Fig. 27,	\$10.00
92.	Tube Guinea and Feather Experiment, with Stop Cock, on stand, \$4.00 to	10.00
93.	Magdeburgh Hemispheres, six inches in diameter, with Ball and Socket Handles, highly finished,	15.00
94.	Hemispheres of extra thickness and finish, for exhibiting the pressure of the air, Fig. 34, \$5.00 to	8.00
95.	Brass Plate with Sliding Rod and Hook, for experimenting in an exhausted Receiver, six inches in diameter,	6.00
96.	Brass Plates and Sliding Rods, from \$3.00 to	4.00
97.	Large Fountain for Vacuo; seven-inch Brass Plate, Receiver three feet high, and Stop Cock, on Mahogany stand,	15.00
98.	Improved Fountain for Vacuo, with Tall Receiver, Brass Plate, and Stop Cock with Jet, \$6.00, 8.00,	10.00
99.	Fountain for Vacuo, Cock, Jet, and stand, Fig. 28, \$4.00,	5.00
100.	Double Transferrer, with two seven-inch Plates, three extra size Cocks, and two Gallon Bell Receivers,	20.00
101.	Double Transferrer as above, smaller, \$8.00 to	15.00
102.	Syringe and Lead Weight for the elasticity of the air, \$4.00 to	6.00
103.	Strong Glass Globe with Cap, Stop Cock, and Jet for condensed air fountain, and Fountain by Expansion, Fig. 30,	4.00
104.	Bachus Experiment, a pleasing illustration of elasticity, \$6.00 to	8.00
105.	Small Air Pump for exhausting and condensing, with Brass Plate, and Glass Tube to show with a Tall Receiver the absurdity of suction,	7.00
106.	A Steel Balance, on mahogany stand, with Glass Globe, Stop Cock, and Weights, for weighing air, \$6.00 to	10.00
107.	Wightman's new arrangement for weight of air, \$3.00 to	7.00
108.	Toricellian Receiver, Barometer Tube, and Cup for illustrating the Barometer,	3.50
109.	Expansion Gauge with tube 36 inches long for showing with the Torricellian Receiver that the <i>force</i> of expansion is always equal to <i>pressure</i> , \$1.50 to	2.00
	Wightman's Bell Apparatus for vacuo; this has been much approved. (See Report of Judges.)	
110.	Large Size for Leslie's Pumps,	6.00
111.	Medium Size for Wightman's Table Pump,	5.00
112.	Small Size for portable Table Pump,	4.00
113.	Apparatus for striking Flint and Steel in vacuo, \$3.00 to	4.00
114.	Wightman's Liquid Transferrer of Glass for showing the expansion and pressure of the air, \$3 00	5.00
115.	Bolt Head Experiment; Glass Globe with long neck and brass plate, \$1.50, and tall open top Receiver, \$3.00. This	

No.	Receiver has a glass plate to cover the top, and is used with experiments. -	
116.	Six 3-inch Glass Cubes with Brass Caps for breaking them by pressure or expansion; and Wire Guards, Fig. 40, \$2.50	\$3.00
117.	Glass Cubes as above, without Caps or Guard, per doz.,.....	1.50
118.	Small Steel Balance with Glass Globe and counterpoise on stand for explaining <i>why</i> a pound of feathers is heavier than a pound of lead, Fig. 39,	4.00
119.	Larger apparatus for feathers and lead, \$5.00	6.00
120.	Lungs Glass, illustrating expansion of air, \$1.50 to	4.00
121.	Improved Weight Lifter; a glass vessel on a mahogany tripod stand, with which the materiality of the air may be shown, the frictionless pump illustrated, and the great pressure of the air shown by raising 100 lbs. by simple exhaustion with a Syringe or Air Pump, Fig. 29, \$5.00 to	6.00
122.	A Flexible Lead Tube 3 feet long, with connectors to attach the "Weight Lifter" to the Lever Pump,.....	1.50
123.	Piston Weight Lifter. This is a glass cylinder having a piston to which weights are suspended. The piston is packed with elastic leather, and should be kept oiled. This apparatus should be attached to the lever pump, unless the syringe is of large size. No. 121 is more convenient and not so easily deranged, \$5.00 to	7.00
124.	Copper Vessel, for Condensed Air Fountain for Portable Pump, B, Fig. 35,	2.50
125.	Copper Condensed Air Fountain, containing several gallons, with a variety of pleasing Jets, with Condenser complete; *.*These fountains jet vertically, which admits of the pleasing experiment of supporting a ball on a jet of air or water, \$10.00 to.....	25.00
126.	Revolving Jet for Condensed Air Fountains,.....	1.00
127.	Double Revolving Jets for Condensed Air Fountains,.....	1.50
128.	Ball and Jet, by which a ball is sustained upon the summit of a jet of air or water, from No. 125,	1.00
129.	A Ball and Glass Pipe. The Ball placed upon one end (the cup) cannot be blown off, and on the other is supported upon a jet of air. It is used with the mouth.....	.62
130.	Pneumatic Paradox of Brass, with tube to connect it with a condensed air vessel, to show the adhesion of flat valves when attempted to be forced off by a current of air,	1.00
131.	Bladder Glass, with which bladders are broken by pressure, Fig. 36,	1.00
132.	Bladder Glass, with Brass Cap for attaching a Condenser to break the bladder by internal pressure, \$1.00	1.50
133.	Bladder Glass and Hand Glass combined,.....	1.25
134.	Hand Glass, to show the pressure of air, Fig. 33,75

No.		
135.	India Rubber Glass, to show pressure and expansion,	\$1.00
136.	Wightman's Simple Apparatus for showing the descent of smoke in vacuo, procuring carbonic acid gas from burning charcoal, with Taper Stand, Pendant, and Receiver complete,	4.50
137.	The above, with additions for a Double Transferrer,	6.00
138.	Mercury Shower, by which the mercury is forced through the pores of hard wood, Fig. 38, \$1.50	2.00
139.	Brass Plate with Wood Cylinder showing the porosity of wood,	1.00
140.	New Piston Expansion Stand of Brass, with Weights for force of expansion,	4.00
141.	Expansion Stand, with Weights and Bladder or Bag,	2.50
142.	Fire Syringe, for igniting tinder by condensing the air, with Box of prepared tinder,	2.00
143.	Tall Glass Jar, with enamelled Balloon for expansion,	1.25
144.	Tall Glass Receiver for Jar and Balloon, Fig. 32, \$2.00	2.50
145.	Balloon and Tall Glass Jar filled with alcohol and covered with india rubber. This Balloon has a car and man attached, and illustrates many of the laws of fluidity. \$3.00 to	6.00
146.	Balloons with Car and Man, \$1.25	1.50
147.	Water Hammers, showing that the collision of water in a vacuum produces a sharp noise like solid bodies, \$1.00, 2.00,	3.00
148.	Revolving Fans and handle, to show resistance of air,75
149.	Windmills in vacuo, for resistance of air, \$6.00 to	15.00
150.	Leslie's Freezing Apparatus of Receiver, Acid Pan and Cup, Fig. 39, \$1.50 to	6.00
151.	Magic Bottle, from which water will flow through the bottom when the stopper is removed,75
152.	Leather Sucker with brass tube and block of wood,50
153.	Glass model of Diving Bell, \$1.50	2.00
154.	Bell Glass Receivers, plain, as Fig. 40, \$.38, .75, 1.00, 1.50, 2.00, 2.50,	3.50
155.	Bell Glass Receivers, swelled, as Fig. 39, 50 cts. to	4.00
156.	Bell Glass Receivers, swelled and open top, as Fig. 38, \$3.00, 4.00, 6.00 and	8.00
157.	Tall Glass Receivers, open top with glass covers, as Fig. 31, \$2.00, 3.00 and	4.00

ELECTRICITY.

158.	Plate Electrical Machines of improved construction, perfectly insulated, with Glass Shaft and Brass Conductor, of superior finish, diameter of plate from 18 to 36 inches, \$35.00 to	150.00
159.	Plate Machines, brass mounted, with glass pillars, mahogany base and brass conductor, diameter of plate 16 inches,	25.00
160.	Cylinder Electrical Machine, 10 inches diameter, insulated,	

No.	and efficiently mounted for procuring the full power of the instrument, with Clamp, Chains, and Pith Ball Electrometer,	\$30.00
161.	Cylinder, 8 inches in diameter, mounted as above,	25.00
162.	“ 6 “ “ “ “ “	15.00
163.	Batteries of 12 3-quart Jars, best form and arrangement, in mahogany case, with Sturgeon's improvements,	30.00
164.	Battery of 9 3-quart Jars, in mahogany case,	20.00
165.	“ 4 “ “ “ “ “	12.00
166.	“ “ “ pint “ “ “	8.00
167.	Superior Leyden Jars, made expressly for the purpose, pints, \$1.25; quarts, 2.00; 2 quarts, 2.50; 3 quarts, 3.00; 4 quarts, .	4.00
168.	Common Leyden Jars, pint, \$1.00; quart, 1.25; 2 quarts,	2.00
169.	Leyden Jars with Bent Rods for suspension and insulation, . .	2.00
170.	Improved Universal Discharger, Fig. 44, \$5.00, 6.00, and	8.00
171.	Best Jointed “ glass handle,	4.50
172.	Common Jointed, “ “ “	4.50
173.	“ 2 Ball “ “ “ without joint, . .	2.00
174.	Single Ball “ or Directors, \$1.00	1.50
175.	Pith Ball Electrometer, 50 cts.,75
176.	Quadrant “	2.50
177.	Lane's Discharging Electrometer, \$2.00,	2.50
178.	Cuthbertson's Balance “ by which the force of the shock or charge is weighed,	6.00
179.	Harris's Balance Beam Electrometer,	6.00
180.	“ Unit Jar, “	4.00
181.	Coulomb's Tortion “ \$10.00 to	15.00
182.	Bennett's Gold Leaf Electroscope, (superior)	5.00
183.	“ “ “ “ with Condenser,	6.00
184.	“ “ “ “ common,	4.00
185.	Cavallo's Pith Ball “	3.00
186.	Hauy's Needle “ with magnetic needle and insulated forceps,	2.50
187.	Saussure's Electroscope,	2.00
188.	Jars with movable coatings, to explain the Leyden Jar,	2.00
189.	Miser's Plate, in mahogany frame and handle, for giving shocks in an amusing manner,	1.50
190.	Magic Picture, \$2.00 to	3.00
191.	Miser's Plate with one coating, movable,	2.00
192.	Sulphur Cone in Glass,50
193.	Rod of Sealing Wax from 1 to 1 1-2 inches diameter, \$1.00, to	1.50
194.	Volta's Electrophorus, all of metal, rendering it of increased power; all parts are useful for other experiments, \$3.00 to . .	6.00
195.	Page's Electrical Syringe, \$4.00 to	6.00
196.	Apparatus for ignition of phosphorus,	2.00
197.	Electrical Windmills, 50 cts. to	1.00
198.	Point in a glass tube for taking a spark,38

No.		
199.	Pointed Rod, with three different sized Balls for Sparks, \$1.00 to 3.00; Ball and Point,	\$0.50
200.	Mahogany model of the Gable end of a house, for illustrating the effects of perfect and broken conductors, \$1.50 to	2.50
202.	Mahogany model of a Thunder House, hinged to be blown down by a gas pistol within, Fig. 45, \$4.00 to	6.00
203.	Japanned Tin Fire or Lightning House, demonstrating like the preceding the utility of conductors,	4.50
204.	Brass Electrical Cannon on wheels, \$4.00 to	5.00
205.	" " Pistols, Fig. 42, \$1.50 to	3.00
206.	Electrical Flyers or whirls with pointed Rod, 38 cts. to63
207.	" Inclined Plane, \$1.50 to	3.00
208.	" Tellurian or Season Machine, \$1.50 to	3.00
209.	" Fox Chase,	2.00
210.	" Chime of Three Bells, \$2.50 to	3.00
211.	" " Five " \$6.00 to	8.00
212.	" Gamut of Eight " with revolving Clappers, ...	15.00
213.	Long Haired Man, 50 cts.75
214.	Tissue Figure, new and beautiful, \$1.00 to	2.00
215.	Tissue Tassel,75
216.	Electric Spider,37
217.	Brass Plates for dancing images, \$3.00 to	6.00
218.	Common " " " neatly japanned on stands, \$1.50 to	3.00
219.	Glass Cylinder for dancing balls, 50 cts. to	1.50
220.	Electrical See Saw, with figures,	3.00
221.	" Swing " "	2.50
222.	" Swan, 50 cts., Glass Dish for Swan 75 cts.,	1.25
223.	" Sportsman, Jar and Birds, on stand, very neat,	4.00
224.	" Syphon and Brass Bucket,	1.00
225.	" Bucket,75
226.	" Egg Stand; for 4 eggs to illuminate at once,	1.50
227.	Spiral or Diamond Tubes, 2, 3, and 4 feet long, \$2.00, 3.00, ..	4.00
228.	" " " on stand,	3.00
229.	" " " on stand, with Revolving Balls, \$6.00 to	8.00
230.	Luminous Star on a stand,	1.75
231.	" Cross "	2.00
232.	" Letters, Words, or Names, per letter, 25 cts. to50
233.	" Diamond Jar, \$1.00 to	5.00
234.	" Aurora Tube, with Stop Cock, complete,	5.00
235.	" " " arranged without cock, \$3.00 to	4.00
236.	" Flask with Brass Cap and Point,	1.50
237.	" Profile of Franklin, in frame 2 feet square,	4.00
238.	" word " Light," \$3.00, " Lightning," upon glass, ...	5.00
239.	Brass Ball on stand for igniting Cotton and Rosin,75

No.		
240.	Hydrogen Gas Generators, for charging pistols and cannons, \$3.00 to.....	\$5.00
241.	Electrical Powder Bombs, in which gunpowder will be ex- ploded with certainty,.....	1.00
242.	Electrical Mortar and Ball, for firing with oil,.....	1.00
243.	Glass Globe with Caps, Sliding Rod, Balls, Points, and Cock, for showing the effect of the spark in air of various density,.....	5.00
244.	Insulated Stools of mahogany, neat and strong, \$3.00 to.....	5.00
245.	Apparatus for magnetizing steel rods,	2.00
246.	Ether Cups with handle,.....	.50
247.	Paper Figures, (copper plate,) for dancing, each 12 cts. to25
248.	Pith Images for image plates, 38 cts. to50
249.	Best Singer's Amalgam in boxes, 1 oz. 12 1-2 cts., 2 oz.,25
250.	Pith Balls, per dozen, 25 cts. to.....	.50
251.	Six Balls of various woods, baked for illumination, each,....	.25
252.	Prepared white and black Riband, per yard,17
253.	Polished Copal, for Rubbing, 50 cts. to.....	1.00
254.	“ Amber, “ 75 cts. to.....	1.00
255.	Brass Balls on stems, for Leyden Jars, 20 cts. to50
256.	“ “ of various sizes, from 12 cts. to	4.00
257.	Italian Tin Foil, best for coating Jars, (imported by J. M. W.) per square foot, 8 cts. to.....	1.50
258.	Brass Chain, per yard, 12 cts. to 17 cts. Iron Chain, 8 cts. to	.10

CHEMISTRY.

259.	Improved Rack Compound Blowpipe, see Fig. 53,	150.00
260.	Compound Blowpipe, without Rack, with vessels similar, to Fig. 53, \$75.00 to	100.00
261.	Compound Blowpipe, with Pneumatic Cistern combined, Fig. 49,.....	25.00
262.	Compound Blowpipe, on Pepy's Plan, with column of pres- sure, \$20.00 to.....	30.00
263.	Cooper's Pneumatic Cistern, of tinned copper,	25.00
264.	Copper Pneumatic Cistern, for the lecture table,	5.00
265.	“ “ “ various sizes and forms, from \$5.00 to.....	50.00
266.	Cast Iron Mercury Cistern, with Pepy's Gas Holder attach- ed; the form and arrangement is superior to “ Newman's ” English, at £9,	30.00
267.	Chemical Furnaces for the laboratory, lined with soap stone, with Muffle, Tube Holes and Sand Bath, \$15.00 to	20.00
268.	Furnaces of smaller size, lined,.....	10.00
269.	Portable Cast Iron Furnaces,	5.00
270.	Wightman's large Oxygen Retort of Iron, with Brass Head,	

No.	for the chlorate or nitrate of potassa, adapted for Furnace, No. 267.....	\$15.00
271.	The above Improved Retort of medium size, for Furnace, No. 268.....	10.00
272.	Improved Iron Oxygen Retort, with flexible Tube, 4 feet long, with screwed joints and warranted tight without luting, \$3.00,	3.50
273.	Sand Baths for furnaces, 50 cts. to	1.00
274.	Chemical Tongs with Flexures, for Furnaces, 75 cts. to.....	1.00
275.	Iron Ladles of various sizes, 37 cts. to	1.00
276.	Hessian Crucibles, per nest of five,.....	.17
277.	“ “ “ “ “ extra sizes, 38 cts. to62
278.	Wrought Iron Tubes, for decompositions in Furnace, \$1.50 to	2.00
279.	“ “ “ with Copper Retort and Gallows con- necting,	6.00
280.	Oil Gas Apparatus, adapted to Laboratory Furnace,	12.00
281.	Brass Retort Stand, improved form for shifting the rings in any position with great facility, (4 Rings,)	8.00
282.	The same, less expensively mounted, and with 3 rings,.....	5.00
283.	Iron Retort Stand, 5 feet in height, on Tripod with 4 Rings, \$6.00 to.....	8.00
284.	Common Retort Stand, improved, \$2.00	2.50
285.	English Argand Lamps for oil, with Copper Chimneys,	4.00
286.	Sefstroem's Retort Holder, all of wood, much approved,	2.00
287.	Glass Spirit Lamps, with Ground Glass Caps to enclose the wick,.....	1.00
288.	Pyrometer, simple and sensitive, with Spirit Lamp, Fig. 47, .	4.00
289.	“ “ “ without Lamp,	3.00
290.	Conductometer for showing the capacity of different metals to conduct heat by the firing of phosphorus, \$1.50, with lamp,	2.50
291.	Compound Bars, for showing the unequal expansion of metals, 50 cts. to.....	1.00
292.	Gauge and Rod for showing the expansion of metals in all directions,	1.50
293.	True Parabolic Reflectors, heavy silver-plated, 15 inches in diameter, inclosed in mahogany cases,..... :	50.00
294.	Set of Apparatus for above, complete,	10.00
295.	Parabolic Reflectors of planished tin on stands, with Iron Ball, Stand, and Air Thermometer,	6.00
296.	Leslie's Cube and Sliding Stand, for above,.....	1.50
297.	Sliding Stands for supporting apparatus, 75 cts. to.....	1.00
298.	Improved Air Thermometer, on sliding stand,.....	1.50
299.	Air Thermometers, tubes mounted,.....	1.00
300.	Leslie's Differential Thermometer, on sliding stand, \$3.00 ...	4.00
301.	Aphlogistic, or Flameless Lamp, with Cap and Platina coil,..	1.25
302.	Leslie's Radiator, with different colored sides, for showing the radiation from those surfaces,75

No.		
303.	Fire Syringe, for illustrating latent heat,.....	\$2.00
304.	Plain Brass Blowpipe, 50 cts.63
305.	Bergman's Ball Blowpipe, with 2 Jets and Ivory Mouthpiece, .	2.00
306.	Ball Blowpipe, plain, \$1.00	1.25
307.	Wollaston's Pocket Blowpipe,	2.50
308.	Hydrogen Gas Generators, Fig. 50, from \$3.00 to.....	10.00
309.	Superior Gas Bags, double thickness, warranted tight, 2 galls.,	2.00
310.	“ “ “ “ “ “ “ “ 3 “	3.00
311.	Stop Cock and Jet, for Gas Bags,	1.50
312.	Brass Hydrogen Bubble Pipe,63
313.	Set, including 2 gallon Bag, Cock, Jet, and Bubble Pipe,....	4.00
314.	Glass Receiver, with Cap, Connector, and Stop Cock, for transferring gases to bags, &c., \$3.00, without Cock and Connector,.....	1.50
315.	New Apparatus for the combustion of metals in Chlorine without the escape of the gas,.....	8.00
316.	Same Apparatus arranged for showing the absorption of mu- riatic acid gas and ammoniacal gas by water,.....	12.00
317.	Pendent Candlesticks for letting down into Receivers, 50 cts.	.75
	“ Capsules for deflagration in Receivers, 25 cts. to...	1.00
318.	Davy's Safety Lamps, (imported,).....	5.00
319.	Wire Gauze, with handles, for experiments on flame, 25 cts.,	.37
320.	Porcelain Evaporating Dishes, not liable to stain or crack, 25 to	1.00
321.	Glass “ “ “ 25 cts. to38
322.	Porcelain Mortars and Pestles, \$1.00 to.....	3.50
323.	Iron Mortars and Pestles, \$1.00 to.....	2.00
324.	Glass “ “ “ 50 cts. to.....	2.00
325.	Agate “ “ “ \$4.00 to.....	7.00
326.	Steel Spatulas, various sizes, 38 cts. to.....	1.00
327.	“ Forceps, 50 cts. to.....	.75
328.	Woulfe's Apparatus of three bottles with three necks each, with conducting and safety tubes on stand, pints, \$5.00, quarts,.....	7.00
329.	Hare's Gallows Screws, and Connectors; the most useful for attaching tubes to apparatus,.....	1.00
330.	Wollaston's Cryopherus; improved form, warranted, Fig. 51,	3.00
331.	Palm Glass, boiling, } showing the cold produced }	.75
332.	“ “ beating, } from evaporation, }	
333.	“ “ boiling, very neatly mounted on glass stand,....	1.25
334.	Chemical Thermometers, (London,) graduated from the freez- ing to boiling point of mercury, with jointed scale,.....	6.00
335.	Small Glass Apparatus, showing the diminution in bulk, when water and alcohol, or sulphuric acid is mixed,.....	.38
336.	Glass Apparatus, larger, with two Bulbs and ground stopper,	1.00
337.	Nooth's beautiful Apparatus for impregnating water with car- bonic acid gas; all of glass,.....	15.00

No.		
338.	Glass Syringes, for washing filters, 50 cts. to	.75
339.	Bologna Cups, which are broken by the fall of a small piece of flint into them, when a bullet will not produce any effect, — illustrating unannealed glass; per doz.	1.75
340.	Prince Rupert's drops or tears, for the same, per doz.	1.00
341.	French Hydrogen Balloons, 18 to 20 inches diameter,	4.00
342.	Boxes of Metal, for precipitation, 25 cts. to	.50
343.	Cork Burners, for piercing corks, to fit to tubes,	.50
344.	“ Rasps, for enlarging the holes, 38 cts. 50 cts.	.75
345.	Metal Rings, covered with woollen, in sets of 6, for supporting glass globes on table; per set, \$1.50 to	2.00
346.	Table Anvil of cast iron; very useful, \$1.50 to	2.50
347.	Cutting Nippers; flat and round Pliers and Pincers, 38 cts. to	1.50
348.	Portable Laboratory Scales and Weights, for weighing from 1 oz. to 20 lbs.	10.00
349.	Strong Sheet Lead Hydrogen Jars, for making gas, in quantity, with flexible lead tube, \$3.00,	5.00
350.	Brass Plates with Forceps, with which watch springs are burned in Oxygen, without danger to receiver, \$2.50,	3.00
351.	Flat thin Knives, for dressing corks, 25 to	.38
352.	Pure Lead Tube, made expressly for the purpose, pr ft. 12 to	.17
353.	Superior Brass Stop Cocks, each, \$1.00, \$1.25, \$1.50, and	2.00
354.	Brass Connectors of all kinds, for attaching Stop Cocks,	.38
355.	“ “ for tying in a bladder,	.38
356.	German Luting Clay, for coating Retorts, &c. per lb.	.08
357.	Pulverized White Marble, for Carbonic gas, “ “	.06
358.	Strong Cement for attaching Caps, &c. to Receivers, per lb.	.50
359.	Sets of Chemical Substances, from \$6.00 to	30.00
	Granulated Zinc; Phosphorus; Platina Wire; Sponge; and Foil.	

CHEMICAL WARE OF WHITE FLINT GLASS.

360.	Plain and Tubulated Bell Glasses, from 1 pt. to 2 galls. 38 cts. to	2.00
361.	“ “ “ Retorts, from half gill to 1 gallon, 25 cts. to	1.00
362.	“ “ “ Globe receivers, “ “ “ 25 cts. to	1.00
363.	Globes with 3 Tubulures for uniting gases, \$1.00 to	4.00
364.	Long Neck Matrasses, or Ball Heads, half pint to 1 qt., 38 to	.50
365.	Alembic for sublimation and distillation,	2.25
366.	Superior Test Tubes, per dozen, \$1.25 to	1.50
367.	Dropping Tubes, and for collecting precipitates,	.37
368.	Funnels, from half gill to 2 quarts, 12 cts. to	.75
369.	Chemical Flasks, with Ring round the neck, for cork, 25 cts. to	.50
370.	Air Thermometer Tubes, from 25 cts. to	.75
371.	Thermometer Tubes, for showing the process of making,	.17
372.	Conical Precipitating Glasses, enlarged Case, 25 cts,	.50
373.	“ “ “ like a champagne glass, pr dz.	2.00
374.	Common Test “ per doz.	1.00

No.		
375.	Graduated Measure Glasses, from 75 cts. to.....	\$2.00
376.	Woulfe's Bottles, with three necks, half pints 50, pints 75, qts, .	1.00
377.	Large Stoppered Glass Bottles, extra tight, for Chlorine, half gallon, \$1.00, 1 gallon,.....	1.37
378.	Thin Glass Cylinders, for showing the process of boiling,....	.75
379.	Glass Bell Receivers, for mercury cistern, 2½ by 10 inches,....	.75
380.	S Tubes, with corks, for converting a flask to a retort, each, .	.75
381.	Stirring Rods, 6 to 18 inches long, 6 cts. to.....	.25
382.	Glass Tubing, all sizes, per lb. from 75 cts. to.....	1.25
383.	Safety Tubes, funnel top, 75 cts. to.....	1.00
384.	Welter's Tubes of Safety, 75 cts. to.....	1.50
385.	Tall Bell Receivers, open top, 2 inches diameter, with glass cover instead of stopper, for deflagrations, \$1.00 to.....	5.00
386.	Tall Jars, on foot, for precipitations, &c. 75 to.....	1.00
387.	Funnels, with glass cocks, each, \$1.50 to.....	3.00

CHEMICAL WARE OF GREEN GLASS, WITHOUT LEAD, FOR ANALYSIS.

388.	Tubulated and Plain Retorts, from gill to quart, 38 to.....	.63
389.	Funnels, from half gill to 2 quarts, 17 cts. to.....	.50
390.	Chemical Flasks, with rings round the neck, 25 cts. to.....	.75
391.	“ Digesting Flasks, flat bottom, 25 cts. to.....	.75
392.	Test Tubes, common form, per dozen,.....	1.25
393.	Berzelius' Test Tubes, for arsenic, each, 17 cts. to.....	.25
394.	Glass Tubing, thin and quill, for analysis, per lb. \$1.00 to....	1.25
395.	“ Stoppered Bottles, gill to qrt. extra stoppered, 20 cts. to	.38
396.	Evaporating Dishes, 25 cts. to.....	.50

—
OPTICS.

397.	Astronomical Telescopes, with terrestrial and celestial powers; with Achromatic Object Glass; Rack Adjustment, &c. packed in a case, — Fig. 54,.....	65.00
398.	The same of larger size,.....	75.00
399.	Astronomical Telescope, with extra power, on stand; shuts up to 12 inches; packed in case, \$50.00,.....	60.00
400.	Carpenter's Improved Phantasmagoria Lantern, with spring to hold the Sliders; brass adjusting tubes; Patent lamp; with set of 12 Sliders, for Astronomy, neatly packed in boxes,..	40.00
401.	The Lantern as above, of larger size, with set of 9 movable Rack sliders,.....	75.00
402.	Superior Set of Astronomical Sliders, 6 of which are movable,	30.00
403.	Splendid Lantern, with Improved Lamp, and 35 beautiful Astronomical Sliders, containing 59 diagrams, and can be exhibited on a screen 20 to 30 feet in diameter!.....	200.00

Carpenter's Copper Plate Sliders, on Natural History, correctly and beautifully colored, comprising the most remarkable of the Six Linnæan Classes — as follows;

No.			
404.	Mammalia, in 24 sliders,		407. Birds, in 7 sliders,
405.	Fish, " 5 "		408. Reptiles, 4 "
406.	Worms, " 8 "		409. Insects, 8 "
	Set in Box, with Elements of Zoology, explaining the whole,		\$85.00
410.	Single Sliders, or parts of sets selected; per slider,		1.75
411.	Ancient Costume, in six Sliders and 25 figures,		10.00
412.	English Costumes, from 1053 to 1675, in 4 Sliders, 22 figures,		6.50
413.	Modern Costumes of all nations, in sets of 56 Sliders, in box,		85.00
414.	Single Sliders, or parts of sets of Costumes, selected; each,		1.75
415.	Set of Kings and Queens of England, from William the Con- querer; copied from Hume's England, in 9 sliders,		15.00
416.	Set of 12 Sliders of Scripture History, in box,		25.00
417.	" " 14 " illustrating Botany, from the process of ger- mination, to the most beautiful species of flowers and trees, in box with book,		32.00
418.	Set of 4 views of Public Buildings, &c. in 4 sliders,		8.00
419.	Dioramic Sliders; beautiful views, with moving shipping, ob- jects, &c., each slider, \$5.00 to		6.00
420.	Portrait of Queen Victoria — finely painted,		5.00
421.	" " Prince Albert, " "		5.00
422.	" " Ali Pasha of Egypt, " "		5.00
423.	Moss Rose Bud, which blooms and exhibits a Cupid,		3.00
424.	Movable Sliders of Blooming Carnations; Comic Figures in motion; Lions; Death on the Pale Horse; Bleeding Nun; Combats, &c. in great variety; each Slider from \$1.75 to . . .		3.00
425.	Rack Work, Astronomical Sliders, producing natural motions upon the screen, viz.		
426.	Orrery, with the planets in motion, round the sun,		6.00
427.	The Seasons; the Earth's parallelism in the Zodiac,		6.00
428.	The Tides; and phases or changes of the Moon,		5.00
429.	The Comet, in its orbit; tail always opposite the Sun,		5.00
430.	Venus and Mercury; Apparent Direct and Retrograde Motion,		5.00
431.	Mirrors in sets of 4, viz: Convex, Concave, Cylindrical, and Multiplying, \$5.00, 7.50, and		9.00
432.	Concave, or Magnifying Mirrors, 75 cts. \$1.00, 1.50, 2.00, and . .		3.00
433.	Convex Cylindrical, or Multiplying, each, \$1.25 to		3.00
434.	Prisms; \$1.00, 1.50, 2.00, 3.00, 4.00, and		5.00
435.	Stands for Prisms, \$1.50 to		3.00
436.	Prisms, of plate, flint and crown glass joined together,		6.00
437.	Models of the Human Eye, in three parts, Figures 56, 57, 58, with large Sectional Diagram and book of explanation, . . .		12.00
438.	Copperplate Sectional View of the Human Eye, 16 by 12 in. showing the comparative thickness and arrangement of all the various parts, beautifully colored,75
439.	Fantascope, or Magic Wheels, with from 6 to 12 plates,		2.00
440.	Improved Apparatus for illustrating the angle of Incidence and Reflection, \$3.00 to		5.00

No.		
441.	Lenses in sets of six; 2 inches in diameter, in box,	\$8.00
442.	Sections of six Lenses, for showing the construction, in box,	4.00
443.	Multiplying Glass; making one object appear many, 50 cts., . .	75
444.	Camera Obscuras, portable, with which, on transparent paper, correct drawings may be made in miniature of landscapes, &c., mahogany, very neat, \$4.50 to	6.00
445.	Field Camera Obscuras, with the beautiful French prism, in- stead of lens and mirror; the picture is thrown on a sheet of paper 12 to 16 inches square, \$15.00 to	20.00
446.	Carpenter's Telescopic Kaleidoscope. The common instru- ment is confined to the objects enclosed in one end. In ad- dition to which, the Telescopic gives the same beautiful changes to any object near or distant. A fire appears like brilliant fireworks, and figures and parts move in the most grotesque manner; enclosed in a neat case, with directions,	5.00
447.	Carpenter's Common Kaleidoscope, in brass,	2.50
448.	A plain do. 25 cts. to	38
449.	Compound Microscopes, in neat polished boxes, with sliders, rack adjustment, &c., \$15.00 to	25.00
450.	Gould's Pocket Microscope, in case,	15.00
451.	Compound Microscope, with one power of brass, in box,	5.00
452.	" " " two " " "	8.00
453.	" " " three " " "	10.00
454.	" " " " magnifiers; three Ivory sliders; insect box; forceps, &c., in polished box, with direc- tions,	10.00
455.	Botanic Microscopes, with three powers; forceps; sliding stage; in neat mahogany box,	4.00
456.	Pocket Botanic Microscopes, with three powers; sliding stage; mirror, and insect box, in cylinder case,	4.00
456.*	Flower Microscopes; two powers, sliding forceps and point, in pocket case, \$2.00,	2.25
457.	Flower Microscopes; two powers; plain, without case,	75
458.	Tube " in case,	75
459.	" " on tripod, with large field, \$1.25 to	1.50

GALVANISM.

460.	Galvanic Battery, of 100 pairs of double plates, in mahogany frame; Troughs and Iron Racks, figure 59,	85.00
461.	Galvanic Battery, mahogany, 50 pairs of plates, with racks, &c.	45.00
462.	Sliding Forceps, for convenient experimenting, with Batteries, \$2.00 to	5.00
463.	Apparatus for decomposing water, 75 cts. \$1.00,	2.00
464.	" " " " and collecting the gases in separate tubes, \$3.00 to	4.00

No.		
465.	Large Double Decomposition Apparatus, with stop cocks, for collecting the gases without disturbing the tube, \$10.00 to	\$12.00
466.	V Tube, for decomposing neutral salts,	1.50
	Gold, Silver, and Copper Leaf, for combustion, &c.	
467.	Pair of Handles, for extending the contact for shocks, \$1.50 to	3.00
468.	Improved Calorimeters, on Hare's construction, with thick zinc plates, \$30.00 to	75.00
469.	Faraday's Apparatus, for chemical decompositions, \$5.00 to	7.00
470.	Cylinder Calorimeters, of copper and zinc, from \$2.00 to	7.00
471.	Voltaic Gas Pistol, figure 60, \$2.50 to	3.00
472.	" Powder Cup, figure 61, 50 cts. to	1.00

MAGNETISM.

473.	Compound or Combined Magnets, figure 62, according to power, \$5.00 to	15.00
474.	Horse-shoe or U Magnets, figure 63, 25 cts. to	3.00
475.	Bar Magnets, 25 cts. to	1.00
476.	Set of Bar Magnets, in case, \$2.50 to	3.00
477.	Magnetic Needle, on stand, for experiments, figure, 65,	1.00
478.	Pocket Compass, with Agate Cap Needle, in brass boxes, \$2.50 to	5.00
479.	Pocket Compass, in Gilt Watch Cases, \$1.25 to	2.50
480.	" " in mahogany box, \$1.25 to	2.00
481.	Various Magnetic Toys; Ships, Fish, Swans, Crocodiles, Spaniels, &c. in Boxes, with Magnet, 38 cts. to	2.00
482.	Horse-shoe Magnet and Y, armature, figure 62, \$1.00 to	2.00
483.	Star formed plate and Bar Magnet,	1.00
484.	Horse-shoe Magnet, with Rolling armature, figure 66, \$3.00 to	5.00
485.	Astatic or Neutralized Needles, on stand,	1.50
486.	Dipping Needle, with Agate Cap, on stand; from \$3.00 to	5.00

ELECTRO-MAGNETISM, AND MAGNETO ELECTRICITY.

Cylindrical Batteries, of copper and zinc, A. figure 67.

487.	Large size, with card brush and wires,	7.90
488.	Medium size, " " " " "	5.00
489.	Small " for medical use,	2.00

** These Batteries are charged with a solution of Sulphate of Copper, (blue vitriol) by which the power of the Battery is sustained, and are amply sufficient for all Electro Magnetic Experiments.

490.	Oersted's Apparatus for showing the deflection of the Magnetic Needle, figure 68, \$2.00 to	2.50
491.	Helix on stand, for showing the induction of Magnetism in a soft iron bar, figure 70, 200 to	3.50

No.		
492.	Magnetic Needle, on stand, Fig 65, 75 cts, \$1.00 to.....	\$1.50
493.	Magic Ring, with Armatures, showing force of Magnetism by Induction, will sustain 50 to 75 lbs. Fig. 74, \$2.50 to.....	3.50
494.	Magic Ring and Armatures, of large size, with ball and socket handle, will sustain 150 to 200 lbs.....	8.00
495.	Electro Magnets, of soft iron, wound with copper wire, Fig. 71, 75 cts. \$1.00, and.....	1.50
496.	Electro Magnets, in frames of large size, to order, \$5.00 to..	50.00
497.	De La Rives' Ring, in Floating Battery,.....	1.00
498.	Ampere's Coil, " " "	1.00
499.	Analytical Apparatus, Fig. 83, for illustrating the effect and object of the soft iron bar or wires, the primary or battery coil of large wire, and the induced coil of fine wire, all of which are generally used in Electro Magnetic Apparatus for shocks, whatever the form may be, \$12.00 to.....	20.00
500.	Analytical Apparatus of larger size, with Page's Armature at- tached, in addition to the Steel Break piece, \$20.00 to.....	25.00
501.	Page's Revolving Magnet, showing rapid rotation, Fig. 76, and illustrating the principle of the Magneto Electric Machine,.	5.00
502.	Page's Revolving Armature, Fig. 73, \$4.50 to.....	5.00
503.	" " " for Shocks, Fig. 79,.....	6.00
504.	Revolving Rectangle,	6.00
505.	Page's Revolving Ring, \$4.00 to	5.00
506.	Rotating Bell Engine, Fig. 77,	10.00
507.	Revolving Armatures on Wheel, Fig. 75,	5.00
508.	Double Revolving Magnets,	8.00
509.	Magnet revolving round its own axis,.....	6.00
510.	Revolving Wire Frame,.....	8.00
511.	" Cylinders,.....	8.00
512.	Ampere's Rotating Battery,	6.00
513.	Marsh's Vibrating Wire, \$3.00, with Magnet, Fig. 78,	6.00
514.	Barlow's Spur Wheel, with Electro Magnet, Fig. 72,.....	3.50
515.	Sturgeon's Disc, " " "	3.50
516.	Vibrating Magic Circle, \$5.00 to.....	8.00
517.	Double " " Fig. 81, \$10.00 to.....	12.00
518.	Vertical Galvanometer, with adjusting Screws, Fig. 69,	6.00
519.	Common " of large size,	3.00
520.	Horizontal " with adjusting Screws,.....	6.00
521.	Page's Compound Magnet and Electrotome, Fig. 80, \$8.00 to	12.00
522.	Double Helix and Electrotome,	25.00
523.	Page's Reciprocating Engine,.....	12.00
524.	Upright " "	15.00
525.	Bell Engine, \$20.00 to.....	25.00
526.	Medical Coil for Shocks, \$6.00 to.....	8.00
527.	Magneto Electric Machine, for Shocks and Sparks, Fig. 84, \$25.00 to	75.00

No.		
528.	Handles of German Silver for Shocks, \$2.50 to.....	\$3.00
529.	Rotating Coil in fixed Ring,	6.00
530.	Rotating Thermo Electric Arch, Fig. 82,.....	6.00

☞ All the other Illustrative Apparatus in "Davis's Manual," can be furnished to order.

ASTRONOMY AND GEOGRAPHY.

531.	Large Orrery on Mahogany Stand, with Brass wheel work, and a Spring by which the Planets revolve round the Sun, twenty to thirty minutes. The arm of Herschel is four feet in length, and the motions of the Planets are relatively correct. The Moon revolves around the Earth, and all the Planets have cords to retain the parallelism of their axes. It is very portable, and packed in a case,.....	40.00
532.	Superior Orrery on Brass Stand, Gilt Sun, Crank, &c. Fig. 85,	25.00
533.	Orrery on Mahogany Stand, with Zodiac, Gilt Sun, Crank, and Wheel work, excellent for Schools,.....	8.00
534.	Orrery for suspension in the School Room. The Planets revolve on their axes, and round the Sun, \$2.50 to.....	4.00
535.	Superior Tellurian or Season Machine, on Brass Stand, Fig. 86,	10.00
536.	Improved Tellurian or Season Machine, on Mahogany Stand, showing all the phenomena of the Seasons and Eclipses,..	6.00
537.	Tide Dial, fifteen inches diameter, which, by turning a crank, illustrates the daily change in the tides, the diurnal motion of the earth, cause of Eclipses, and shows the Earth's umbra, and penumbra, with Gilt Sun on Stand, Fig. 87,	6.00
538.	Tide Dial as above, without Stand,.....	5.00
539.	Whirling Apparatus, with gearing to illustrate the supposed cause of the Planets being flattened at the poles,.....	3.00
540.	Loring's Premium Globes, eighteen inch, on high Pedestal Stands, per pair,.....	100.00
541.	A pair of Linen Covers and Packing Cases,	10.00
542.	Loring's twelve-inch Globes, on Mahogany Stand, \$30.00, covers and cases, \$2.00 per pair, complete,.....	32.00
543.	Loring's twelve-inch Globes mounted on Joslin's Metal Stand, Fig. 88,	40.00
543.*	Loring's ten-inch Globes, on Mahogany Stand, per pair,....	20.00
544.	Joslin's six-inch Globes, on Mahogany Stand, per pair, copied from the twelve-inch Loring's,.....	10.00
545.	Five-inch plain Terrestrial Globes for Primary Schools,.....	2.00
546.	Three " " " " " " " "	1.50
547.	Globe of the Moon, (four inch,) giving the names and position of the principal objects seen with the Telescope, by "Smith, London," mounted on Stand,	3.00

No.		
548.	Maps of Europe, Asia, Africa, and North America, mounted on Rollers and varnished, each, \$8.00 to	\$10.00
549.	Maps of the United States, with book of reference, \$10.00 to	12.00
550.	Maps of South America,	6.00

GEOLOGY AND METEOROLOGY.

551.	Set of Minerals, one hundred specimens, arranged according to the Chemical classification, in case,	10.00
552.	Set of Minerals, one hundred specimens, and fifty specimens of shells in case, with catalogue,	15.00
553.	Set of Minerals and Shells in cabinets and drawers, \$20.00 to	50.00
554.	Wollaston's Reflecting Goniometer, divisions to minutes, \$18.00 to	20.00
555.	Clinometers for taking the Angles, etc. of Strata, in case,	6.00
556.	Copper Rain Gauge, much approved, and adapted for any situation or climate, (warranted correct,) \$6.00 to	7.00
557.	Superior Pediment Barometer, with Rack vernier, Thermometer, and polished Mahogany Frame,	16.00
558.	Plain Pediment Barometer, with Thermometer,	12.00
559.	Barometers of high finish, from \$20.00 to	25.00
560.	Self-Registering Thermometers, for day <i>or</i> night,	4.00
561.	" " " " for day <i>and</i> night, on one Frame, with Magnet for adjusting the Indices, \$5.00 to This instrument registers the extremes of heat and cold in the absence of the observer, and <i>the usual price is</i> \$10.00.	6.00
562.	Thermometers, eighteen-inch, in glazed Mahogany frame, with Fahrenheit's and Raumer's Scales,	6.00
563.	Thermometers, fourteen-inch, as above, with F.'s Scale,	3.50
564.	Parlor Thermometer with Ivory Scale upon Ebony, with Fahrenheit's and Centigrade Scale,	3.00
565.	Thermometers with Ivory Scales and Copper Cases,	2.50
566.	" " Metal " " " " "	1.75
567.	" " Ivory " " in Glass Tube Cases, and boxes for the pocket, \$1.75 to	4.00
568.	Thermometers for the pocket, in Mahogany Sliding Cases, Ivory Scales,	2.00
569.	Thermometers, common form, in Japanned Cases, eight-inch, \$1.00, nine-inch, 1.25, ten-inch, 1.50, twelve-inch,	1.75
570.	Alcohol Thermometer, in Copper Case, for low temperatures,	3.00

MISCELLANEOUS.

571.	Numeral Frame, with one hundred and twenty balls, Fig. 89,	1.25
572.	Set of thirteen Wood Models of Solid Geometry, viz: Cube, Sphere, Hemisphere, Prisms, Pyramids, Spheroids, Cone, and Frustums of Cone and Pyramid,	1.25

No.		
573.	Set of sixty-four one-inch Cubes in a box, Fig. 92,.....	\$2.00
574.	Dissected Cone, with Pins, showing the Circle, Ellipse, Parabolic, and Hyperbolic Sections, Fig. 90, \$1.50 to	3.00
575.	Mathematical Paradox, or Curious Block, which <i>fits</i> exactly, and <i>passes through</i> a square, a circle, and triangle,75
576.	Optical Deception, in a box, containing twelve different paintings, which when seen through a perspective, change to entirely different objects,.....	5.00
577.	Magic Painter, exhibiting a copy of any one of four pictures secretly chosen,	1.50
578.	Magic Clock, exhibiting any hour secretly chosen,.....	1.50
579.	Communicative Box, showing the position of figures upon two blocks secretly arranged in another box,.....	1.50
580.	Sun Dials, adapted to any latitude, which should be sent with the order, \$2.00 to.....	5.00
581.	Dissected Models of Arches or Bridges, illustrating the principle of the Arch, \$2.50 to.....	6.00
582.	Sets of Drawing Instruments, in Cases for Schools, \$4.00 to	8.00
583.	Illustration in Wood of the Carpenter's Theorem, viz: That the square described upon the hypotenuse of a right-angled triangle, is equivalent to the sum of the squares described upon the other two sides, Fig. 91, \$1.50 to	2.00

BOOKS.

584.	Wightman's Companion to the Air Pump,25
585.	“ “ to Electricity,.....	.25
586.	Davis' Manual of Electro Magnetism, etc. bound,.....	.75